

RUDDERMASTER

Rudder Angle Indicator

INSTALLATION AND MAINTENANCE INSTRUCTIONS

WARNING: *Raritan Engineering Company, Inc. recommends that a qualified person install this product. Equipment damage, injury to personnel or death could result from improper installation. Raritan Engineering Company, Inc. accepts no responsibility or liability for damage to persons, equipment or injury or death that may result from improper installation or operation of this product.*



INTRODUCTION

The Ruddermaster indicates at a glance how far the rudder is from a straight ahead position. As the steering wheel is turned, the sending unit communicates the angle of the rudder to the calibration box. The calibration box transmits the rudder's position to the meter. The Ruddermaster can be used both as a steering aid and to monitor auto pilot systems.

A complete unit consists of four components:

1. Meter with 5' (1.53m) of two conductor cable
2. Sending Unit with 30' (9.15m) of connecting wire
3. Calibration Box
4. Actuator Rod with Ball Joints

Repeater Units with 15' (4.58m) of connecting wire can be used for additional rudder angle displays.

NOTE: Additional lengths of connecting wire may be ordered.

INSTALLATION PROCEDURE

READ ALL STEPS BEFORE PROCEEDING

Important Installation Note: Sending unit arm must be re-positioned before installation and calibration, see info sheet (L420) included with Sending Unit.

MK445, MK5, or MK6 meters are not water proof. Mount where meter will not be exposed to weather, wash down spray, or direct sunlight. MK2, MK2B** AND MK3B** ARE SPRAY PROOF (IP64).**

MOUNTING Meter and/or Repeater:

1. Using the templates provided, cut out the appropriate size hole.
- 2a. **MK445** - Secure the unit by attaching the faceplate to the mounting surface.

NOTE: Use only stainless steel or chrome plated brass screws.

- 2b. **MK5 and MK6** - Drill four holes for the studs attached to each corner of the meter. Secure using the nuts provided.
- 2c. **MK2**, MK2B** and MK3B**** - Mount meter in hole and secure using meter bracket and hardware supplied. Connect two conductor cable to the meter. **NOTE:** Red wire must be connected to positive (+) terminal on meter. Connect bulb wiring to power source.

The Calibration Box:

Mount within reach of the wires attached to the meter and sender wires. A protected area where wires can be easily connected is best. Remove mounting plate from enclosure and secure using 2 screws provided. Once secured, attach enclosure to mounting plate.

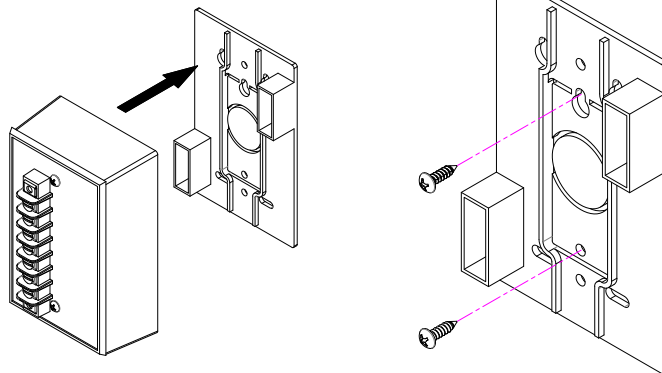

The Sending Unit:

WARNING: TURNING THE WHEEL WITH CENTERING SCREW IN PLACE WILL DAMAGE THE SENDING UNIT. CORRECT POSITIONING OF THE SENDING UNIT IS CRUCIAL TO AN ACCURATE METER READING.

1. Drill a #21 hole 2 11/16" (6.83cm) from center of the rudder post. Tap hole with 10-32 thread. Mount ball joint at one end of the actuator into the hole.
2. Center rudder(s) in the straight ahead position. (This can best be done by marking the steering wheel while under way.)

Use the following criteria when selecting a mounting site for the sender:

- Protected from bilge water immersion or splashing. Sending units are not waterproof.
- The sending unit arm is on the same horizontal plane as rudder arm (when looking from the side).
- The sending unit arm and the rudder arm, when centered, are at right angles to the actuator rod. (The sending unit arm will always remain parallel to the rudder arm.) See Fig. #1 on page 2.
- The distance between the rudder arm and the sending unit arm must accommodate the range of adjustment of the

actuator rod.

- To maintain an accurate meter reading the rudder arm and the sending unit arm should be parallel (when looking from above). See Fig. #1. (It may be necessary to add a spacer.)
3. Once the sending unit is mounted, attach the actuator rod and other ball joint to the arm of the sending unit.
 4. Remove the sending unit's centering screw.

WIRING

Sending Unit, Meters, and Power Leads to the Calibration Box:

1. Connect the three wires from the sending unit to the three "S" terminals. (The red wire to S1, the black wire to S2 and the white wire to S3.)
2. Connect the red wire from the meter to M1 terminal and the black wire to M2 (see Fig. #2).
3. Connect the power leads from the battery. Positive to the B+ and negative to B- terminal. ABYC recommends a minimum wire gauge of #18AWG (1.0mm²) for current carrying conductors of this type.
4. For MK2**, MK2B** and MK3B** back illumination lighting: connect one wire to the panel light switch positive (+) and the other wire to negative (-).

REPEATER WIRING:

Wire both meters in series as per Fig. #3. Disconnect black wire from M2 terminal and, using a crimp connector, attach it to the red wire from the repeater unit. The black wire from the repeater unit should then be connected to the M2 terminal.

EXCEPTION: MK4 with a 0-60 range cannot be wired with a repeater of a different type. MK4 with MK4R may be wired in parallel by connecting the red wire from the repeater to the M1 terminal and the black wire to the M2 terminal.

ADJUSTMENT PROCEDURE:

1. Meter should read zero with rudder centered and power on.

MAKE SURE THE CENTERING SCREW HAS BEEN REMOVED FROM THE SENDING UNIT ARM.

2. Turn wheel hard to starboard. Adjust Full Scale on the calibration box so that the meter indicates full starboard on the rudder.

NOTE: Slight adjustment can be made by loosening set screw in the sender arm and rotating the sender shaft. It is important that the rudder arm and the sending unit arm continue to move parallel to each other hard over port to hard over starboard.

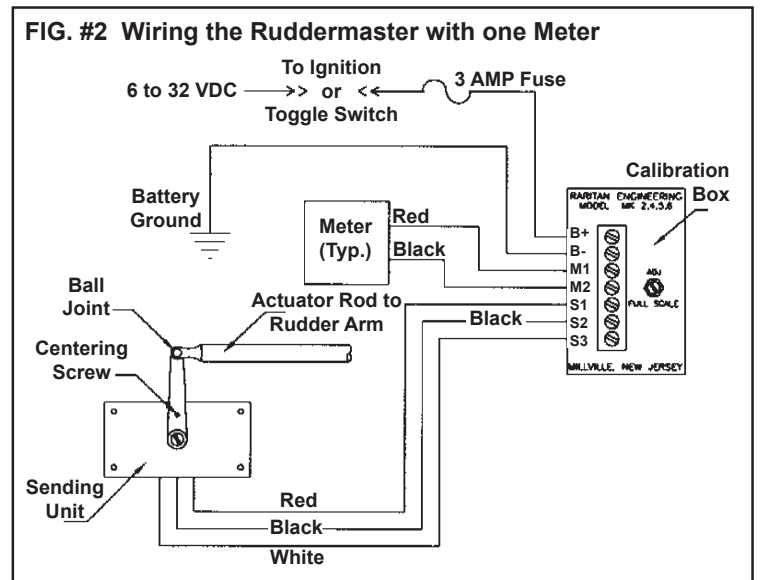
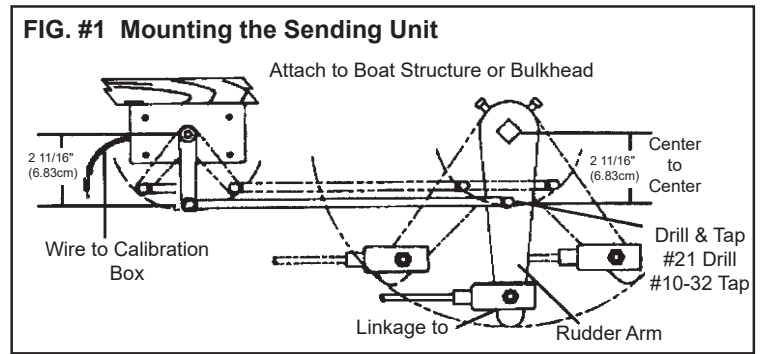

Adjustment with a Repeater:

Since the two instruments are connected to the sending unit, it is necessary to readjust the full scale at the calibration box. Turn rudder full starboard, readjust Full Scale until both meters indicate full starboard.

MAINTENANCE

Apply a drop of #20 oil to ball joints twice a year.

**Specify voltage

TROUBLESHOOTING

Moisture in the Meter:

If meter is no longer readable, it should be replaced.

Meter Indicates the Opposite Direction of Rudder Position:

This indicates that the polarity is reversed. Check the wiring to the calibration box and make sure it is correct. Rewire if necessary.

Meter Indicates Full Scale in one Direction and Short or Over in the Other Direction:

The sending unit is not installed correctly. It must be reinstalled so that the rudder arm and sender arm continue to move parallel to each other.

Erratic Movement of Meter Needle or Needle does not Move Full Scale:

Check connections in the calibration box to make sure they are secure. If a loose connection is not the cause of the problem check the potentiometers in the sending unit and calibration box with an ohmmeter.

Checking the potentiometer in the sending unit:

1. Disconnect the S1 (red), S2 (black) and S3 (white) wires from the Calibration Box.
2. Set the ohmmeter scale to a range setting greater than 5,000 (5K) ohms. Connect the S1 (red) wire to ohmmeter's positive lead and the S2 (black) wire to the ohmmeter's negative lead. Move the wheel in each direction. In one direction the ohmmeter should move smoothly toward full scale.
3. Disconnect the S1 (red) wire from the ohmmeter. Connect the S3 (white) wire to the ohmmeter's positive lead. Move the wheel. Again there should be a smooth movement of reading on the ohmmeter but in the opposite direction.
4. If steps 2 and 3 do not show a smooth movement toward the full scale reading or the ohmmeter reading changes erratically as the wheel is turned it is necessary to replace the sending unit.
5. Reconnect S1 (red), S2 (black) and S3 (white) wires to Calibration Box.

Checking the potentiometer in the Calibration Box:

1. Disconnect the S1 and B+ connections on the Calibration Box.
2. Set the Ohmmeter scale to a resistance of 50,000 (50K) ohms. Connect the ohmmeter's negative lead to the S1 terminal on the Calibration Box. Connect the ohmmeter's positive lead to the B+ terminal. Use a screwdriver to turn the adjustment screw as far as it will go counter clockwise. The ohmmeter scale should indicate 0. Now turn the adjustment screw in a clockwise direction until it stops. The reading on the ohmmeter should show 50,000 (50K) ohms of resistance.
3. If the ohmmeter does not read 0 in a counter clockwise direction or 50,000 (50K) in a clockwise direction, the potentiometer in the Calibration Box should be replaced.

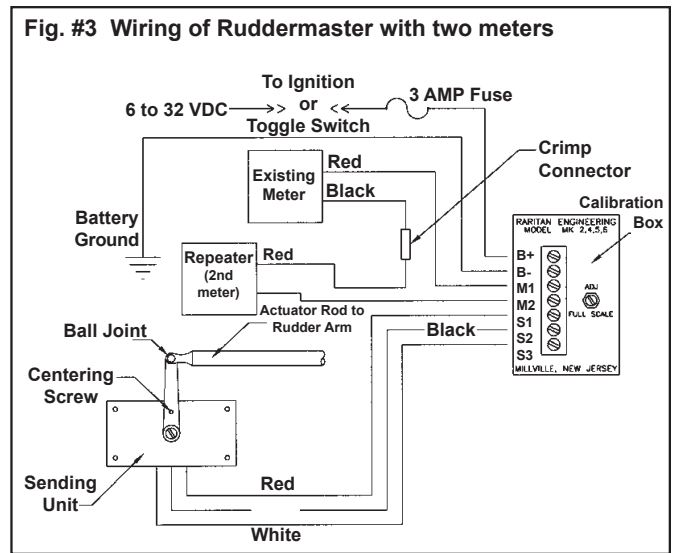

PARTS FOR RUDDERMASTER

MK2M**	Meter for MK2, chrome bezel
MK2MB**	Meter for MK2, black bezel
MK3MB**	Meter for MK3B, black bezel
MK5M	Meter for MK5
MK6M	Meter for MK6
MKDRW	Actuator Rod Assy. (includes 2 ball joints)
MKCB	Calibration Box
MKCBP	Potentiometer for Calibration Box
MKSII	Sender Assembly
MKSP	Sender Potentiometer
W182C*	Wire: meter, 18 gauge, 2 conductor
W183C*	Wire: sending unit, 18 gauge, 3 conductor
F019	10-32 x 3/4ss Set Screw
ERB90-161	MK2 and MK3 bulb, 12V
ERB90-656	MK2 and MK3 bulb, 24V
ERB90-657	MK2 and MK3 bulb, 32V
For repeater units add an "R" to the part #.	

*Order by the foot

**Specify Voltage

DIMENSIONS	SPECIFICATIONS
MK2B**: 2"(5.1 cm) in dia., 2 1/4"(5.7 cm) Deep MK3B**: 3 3/4"(9.5 cm) in dia., 2 7/8"(7.3 cm) Deep MK5: 4"(10.2cm)H, 5 1/8"(13cm)W, 1 1/8"(2.9cm) Deep MK6: 2 7/8"(7.3cm)H, 3 3/4"(9.5cm)W, 1 1/8"(2.9cm) Deep **Voltage	Volts: 12-24 DC Fuse Size: 3 amps Amps: < 1 Maximum number of repeaters = 2; for more, consult Raritan Technical Support

Replacement parts or additional units are available from Raritan Dealers or from Raritan direct. Questions concerning installation or repair can be answered by Raritan Technical Support at either the New Jersey or Florida offices.

LIMITED WARRANTY

Raritan Engineering Company warrants to the original purchaser that this product is free of defects in materials or workmanship for a period of one year from the product's date of purchase. Should this product prove defective by reason of improper workmanship and/or materials within the warranty period, Raritan shall, at its sole option, repair or replace the product.

1. TO OBTAIN WARRANTY SERVICE, Consumer must deliver the product prepaid, together with a detailed description of the problem, to Raritan at 530 Orange St., Millville, N.J. 08332 When requesting warranty service, purchaser must present a sales slip or other document which establishes proof of purchase. THE RETURN OF THE OWNER REGISTRATION CARD IS NOT A CONDITION PRECEDENT OF WARRANTY COVERAGE. However, please complete and return the owner Registration Card so that Raritan can contact you should a question of safety arise which could affect you.
2. THIS WARRANTY DOES NOT COVER defects caused by modifications, alterations, repairs or service of this product by anyone other than Raritan; defects in materials or workmanship supplied by others in the process of installation of this product; defects caused by installation of this product other than in accordance with the manufacturer's recommended installation instructions or standard industry procedures; physical abuse to, or misuse of, this product. This warranty also does not cover damages to equipment caused by fire, flood, external water, excessive corrosion or Act of God.
3. ANY EXPRESS WARRANTY NOT PROVIDED HEREIN, AND ANY REMEDY FOR BREACH OF CONTRACT WHICH BUT FOR THIS PROVISION MIGHT ARISE BY IMPLICATION OR OPERATION OF LAW, IS HEREBY EXCLUDED AND DISCLAIMED. ALL IMPLIED WARRANTIES SUCH AS THOSE OF MERCHANTABILITY AND OF FITNESS FOR A PARTICULAR PURPOSE, IF APPLICABLE, AS WELL AS ANY IMPLIED WARRANTIES WHICH MIGHT ARISE BY IMPLICATION OF LAW, ARE EXPRESSLY LIMITED TO A TERM OF ONE YEAR. SOME STATES DO NOT ALLOW LIMITATIONS ON HOW LONG A LIMITED WARRANTY LASTS, SO THE ABOVE LIMITATION MAY NOT APPLY TO YOU.
4. UNDER NO CIRCUMSTANCES SHALL RARITAN BE LIABLE TO PURCHASER OR ANY OTHER PERSONS FOR ANY SPECIAL OR CONSEQUENTIAL DAMAGES, WHETHER ARISING OUT OF BREACH OF WARRANTY, BREACH OF CONTRACT, OR OTHERWISE. SOME STATES DO NOT ALLOW THE EXCLUSION OR LIMITATION OF INCIDENTAL OR CONSEQUENTIAL DAMAGES, SO THE ABOVE LIMITATION OR EXCLUSION MAY NOT APPLY TO YOU.
5. No other person or entity is authorized to make any express warranty, promise or affirmation of fact or to assume any other liability on behalf of Raritan in connection with its products except as specifically set forth in this warranty.
6. This warranty gives you specific legal rights, and you may also have other rights which vary from state to state.

	530 Orange Street, Millville, NJ 08332 USA Telephone: 856-825-4900 FAX: 856-825-4409 www.raritaneng.com
---	--