

crown head™

CENTRIFUGAL DISCHARGE SERIES AUTOMATIC MARINE TOILET INSTALLATION, OPERATION AND MAINTENANCE INSTRUCTIONS

THE FOLLOWING ARE CAUTIONARY STATEMENTS THAT MUST BE READ AND FOLLOWED DURING BOTH INSTALLATION AND OPERATION.

WARNING:  Raritan Engineering Company, Inc. recommends that a qualified person or electrician install this product. Equipment damage, injury to personnel or death could result from improper installation. Raritan Engineering Company, Inc. accepts no responsibility or liability for damage to equipment, injury or death to personnel that may result from improper installation operation of this product.

WARNING: HAZARD OF SHOCK OR FIRE



Always use recommended fuse, circuit breaker and wire size.

Motors and relays used with this product are "Ignition Protected". They are not however, explosion-proof as defined in 46CFR 110.15-65(e), Subchapter J-Electrical Engineering.

DO NOT run this system dry (without water).

DO NOT run continuously for more than 30 seconds.

WARNING: HAZARD OF FLOODING - Always shut off seacock(s) before leaving the boat unattended.



Whenever possible hose connections should be secured using two (2) all-stainless steel hose clamps. Integrity of clamps, hoses and fittings should be checked periodically.

INTRODUCTION

The Crown Head is a powerful centrifugal macerating toilet that thoroughly breaks down waste in preparation for treatment or holding and requires little maintenance. It can be ordered with a 90 degree or a straight discharge fitting. Available in marine-size or household-style bowl.

OPERATION

CAUTION: The Crown Head motor is designed to be used as a toilet and is not rated for continuous duty.

The Crown Head doesn't require special toilet paper, however, hard objects or stringy substances (paper towels, feminine hygiene products, filter cigarettes, etc.) **must not** be thrown into the toilet as they will cause damage.

A. Momentary Operation Using Momentary Flush Switch (Part#PRS) - not included: Depress button and hold. Water should appear in the bowl within one to four seconds. Flush as necessary.

Model and Serial

MAINTENANCE

1. Refill the reservoir when empty; occasionally check that it has not run dry.

C.P., Cleans Potties, (1PCP32) helps minimize the need for cleaning.

Use only Raritan Cleans Potties as an additive in the Concentrate tank. Other products may cause damage to the internal parts of the toilet.

2. Using C.P. a bio-enzymatic toilet bowl cleaner (available from Raritan Engineering) will keep the bowl clean and fresh smelling.

Do not use any chemical that contains ammonia, ethyl acetate, phosphoric acid or concentrated chlorine bleach as a cleaner. These may cause damage to the toilet.

3. Make a periodic visual check for leaks at the base of the toilet and at hose connections.

4. Check semiannually to ensure all wire terminals and junctions are corrosion-free.

5. When boat is not in use, flushing the system with fresh water will help minimize odors and reduce mineral buildup.

Link to online
Warranty
Registration



WINTERIZING

WARNING: If connected to a Lectra/San or Purasan treatment system there should not be any antifreeze in the system when activating the Lectra/San or Purasan. Injury to personnel or damage to property could result if the Lectra/San or Purasan is activated with antifreeze in the system.

Improper winter lay up is a major cause of marine toilet failures.

1. Close the intake and discharge seacock. Disconnect and drain the intake and discharge hoses. Winterize seacocks and hoses.
2. You will need two buckets, three feet of 3/4" (19mm) hose, three feet of 1 1/2" (38mm) hose and a quart (.95 liter) of non-toxic antifreeze.

NOTE: Use only non-toxic antifreeze in this unit.

3. Pour about one quart (.95 liter) of non-toxic antifreeze into one of the buckets. Place intake hose in this bucket. Place empty bucket under discharge hose. To ensure antifreeze has circulation through the entire toilet, flush until antifreeze is discharged.
4. Antifreeze should remain in the toilet until recommissioning. This will protect both intake and discharge sides of the pump. Pouring antifreeze into the bowl will only protect the discharge side of the pump, allowing the intake side to possibly freeze.

NOTE: Holding tanks, seacocks and treatment systems need to be independently winterized, stored and recommissioned (see manufacturer's instructions).

RECOMMISSIONING

1. Using the buckets, hoses and a gallon of clean water, flush the antifreeze out of the toilet. Dispose of antifreeze properly, in accordance with local and federal regulations.
2. Reconnect the hoses and open both seacocks.
3. Check all connections for leaks with several test flushes.

SYSTEM COMPONENTS

Before starting installation please be sure that all parts that were ordered with your model have been included: The complete Crown Head unit includes: bowl, seat and cover, motor assembly, shroud assembly, siphon and check valve assembly, Concentrate tank, 2 oz. (59ml) of C.P., two mounting strips and an owner's manual.

Crown Head units purchased for use with 120/240 volt AC power will also include a rectified transformer unit (#RTCH24DA), with instructions.

INSTALLATION

Read This Entire Section Before Beginning Installation.

Below water line installations must include vented loops. The top of the loop must be above the waterline at maximum heel to prevent siphoning. (See FIG 3.)

Additional parts required: Stainless steel fasteners, Momentary Flush Switch (#PRS) and a continuous duty solenoid (#CDS*) relay. 1 1/2" (38 mm) I.D. discharge hose (#SFH) and a reinforced 3/4" (19mm) I.D. intake hose, hose clamps, wire, fuse or circuit breaker (see Crown Head Specification chart).

Mounting the Crown Head: Be sure Crown Head is on solid deck construction in a dry location. **Never mount the Crown Head where it may be subject to shower spray or other sources of external water.** Place the supplied rubber mounting strips between the base plate of the Crown Head and the deck, allowing air to circulate under the motor to prevent moisture from accumulating. Use stainless steel fasteners with a minimum size of 1/4" (6 mm).

1. Intake Lines: A 3/4" (19mm) thru-hull fitting and seacock located in an accessible area is required to supply flush water to the bowl. Connect a 3/4" (19 mm) I.D. reinforced suction hose between the seacock and intake pump.

NOTE: An intake In-Line strainer (#163000) is recommended to help avoid the accumulation of debris in the intake pump.

2. Discharge Lines: Connect quality sanitation rated 1 1/2" (38 mm) I.D. hose (#SFH) to the discharge fitting on the toilet and connect to the treatment system, holding tank, or discharge thru-hull fitting, as appropriate.

TIP: To retain water in the bowl install a vented loop in the discharge line.

Allow sufficient space at the side and rear to connect hoses. If space is limited, the bowl can be rotated 90 degrees (a longer hose [#CH42] is required, contact Raritan Technical Support).

* Specify Voltage

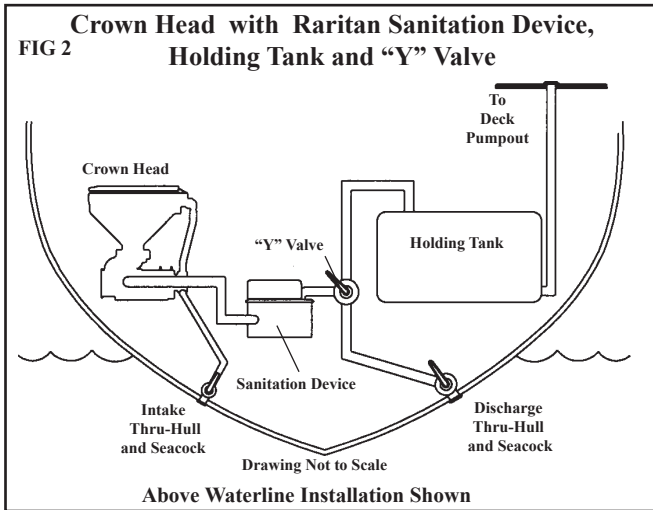

PLUMBING

WARNING: HAZARD OF FLOODING

Toilets mounted at or below the waterline, at greatest angle of heel, and connected to a Seacock/Thru Hull Fitting(s) **MUST** have **VENTED LOOPS** installed in toilet discharge plumbing and between raw water intake pump and toilet bowl.

Install vented loops per manufacturer's instructions. Double clamp all below-waterline connections.

Whenever possible hose connections should be secured using two all-stainless steel hose clamps. Integrity of clamps, hoses and fittings should be checked periodically. Fittings and 90 degree bends should be kept to a minimum to maintain proper performance.

NOTE: Discharge of raw untreated sewage is restricted in all U. S. waters inside the three-mile limit. "Y" Valves, if installed, must direct toilet discharge to a USCG approved treatment system or holding tank and must be secured in that position while inside the three-mile limit.

WIRING

WARNING: RISK OF FIRE - The Crown Head must be wired to a separately fused circuit with no other electrical appliances on the circuit.

1. Measure wire distance from power source to, Pump Relay to, toilet and back to power source. Refer to Specification Table for proper wire gauge and circuit breaker/fuse sizes.
2. Use 16 AWG to PRS (Switch) and Pump Relay blue wires.

12, 24 and 32 VDC Crown Head Units: Wire as per FIG 4. (For momentary switch operation.)

2. Using a protected circuit that is appropriate for the voltage of the unit, connect the positive lead from

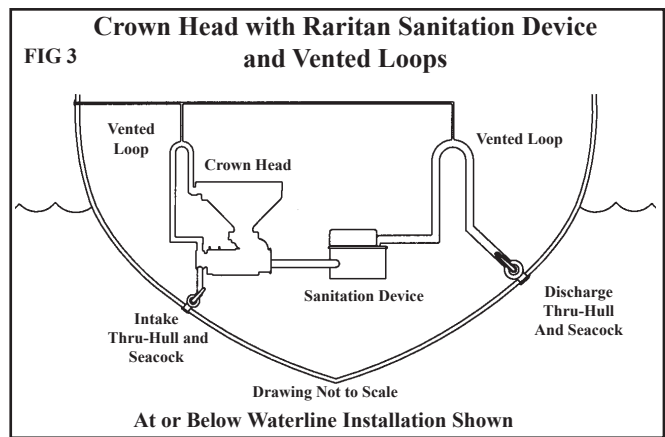

the battery or power source to the "BAT" lug on the relay and connect a lead from the other relay lug to the positive terminal on the Crown Head motor.

3. Connect ground wire from the battery or power source to the negative terminal on the motor.

For VAC 120/240 Crown Head Units: See instructions with transformer units.

SYSTEM START-UP

1. Be sure intake and discharge seacocks are open.
2. Remove the cap from the reservoir and pour in 2 oz. (59ml) of Cleans Potties (1PCP32); fill the remainder of the reservoir with fresh water and replace the cap and siphon assembly.
3. Refer to Operation on page 1. If the toilet does not flush properly, or if water does not enter the bowl within 10 seconds, refer to the Troubleshooting Section. **Running the unit dry will damage the intake pump.**

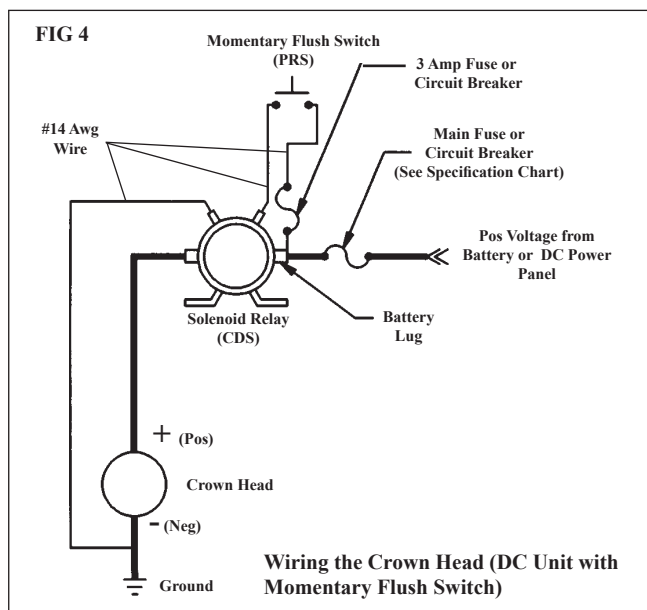

Crown Head Exchange Units

Crown Head Exchange Units are remanufactured units available as a service to the customer. The old pump and motor assembly (LBA) are taken in trade on a remanufactured unit; the bowl, seat, lower cover and **discharge fittings** are kept and reused. When ordering directly from Raritan, a core charge is assessed until the old unit is received by Raritan.

Subject to parts and production availability, exchange units are not always available for shipment. Exchange units include the LBA along with a package of fasteners, new joker valve, mounting strips and a bowl gasket to remount the bowl to the LBA.

ONBOARD FRESHWATER USE: If you would like to retrofit your current Crown Head for use with pressurized freshwater please contact Raritan Technical Support.

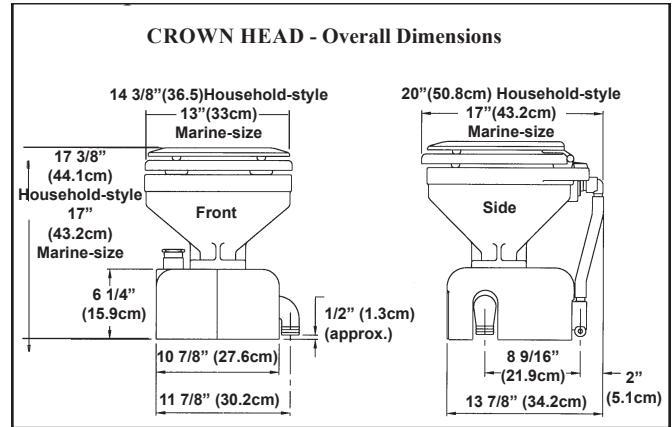

NOTE: Pre-11/87 Standard LBA's utilized a flapper valve on the discharge. If replacing this model, please mention it when ordering; a special discharge fitting will have to be added to the order. Breaker and wire sizes will have to be increased - see Specifications below.

CROWN HEAD SPECIFICATIONS				
A.	Nominal Voltage of Unit (Volts D.C.): For 120/240 VAC units utilizing the rectified transformer, refer to 24 Volt D. C. Specifications	12	24	32
B.	Amperage Draw @ Nominal Voltage	36	20	15
C.	Circuit Breaker /Fuse Requirement (Amps):	50	30	20
D.	Wire Gauge Sizes (AWG) Circuit Length, Battery to Crown Head and Back:	0-15 Ft.	#6	#10
		16-25 Ft.	#4	#10
		26-50 Ft.	#2	#8
		Over 50 Ft. Refer to ABYC (E-9) Recommendations		
E.	Switch Wire Size:	0-50 Ft.	#14	#14
	Switch Wire Fuse Size (Amps):		3	3
F.	Maximum Height of Discharge Vented Loop:	4 Ft. From Base of Toilet		
H.	Maximum Suction of Inlet Pump (Allowable Height of Toilet Above Waterline):	3 Ft. From Base of Toilet		
I.	Duty Cycle:	30 Seconds On; 120 Seconds Off		

TROUBLESHOOTING

WARNING: HAZARD OF ELECTRIC SHOCK - Before beginning any work on the Crown Head, be sure that all power to the unit has been turned off and that the seacocks are in the CLOSED or OFF position.

NOTE: The following information reflects the most probable causes and solutions to problems although not every possible cause and solution is provided.

Any questions regarding servicing or operation of the Crown Head should be directed to our Technical Support Department in Millville, NJ. Please have model and serial number available before calling.

PROBLEM	POSSIBLE CAUSE	SOLUTION
1. Poor pumpout, especially solids.	1A. Clogged discharge line. 1B. Plumbing restrictions, bends and ells. 1C. Clogged Vents. 1D. Mineral buildup in hoses and fittings. 1E. Low voltage 1F. Discharge pump (#CH120) wall not intact.	1A. Be sure discharge seacock is open. 1B. Replumb to eliminate bends and ells. 1C. Clean holding tank vent and vented loop vents. 1D. Clean or replace affected parts. Replace hose if needed. 1E. Check voltage at toilet while toilet is running . If less than nominal voltage of toilet (12, 24, or 32), check condition of batteries and wire sizes. Check terminals and wire connections for corrosion (heat at terminals and junctions indicates a bad or corroded connection). 1F. Reposition pump wall behind macerating teeth cast in housing cavity. Replace if necessary.
2. Poor water flow, especially at front of bowl (or no water flow)	2A. Toilet not level. 2B. Restriction in intake line. 2C. Check ball (#CH12) stuck. 2D. Intake Pump sucking air. 2E. Low voltage. 2F. Intake pump impeller worn or broken loose from center bushing. 2G. Clogged strainer.	2A. Raise rear of toilet; check with level. 2B. Be sure seacock is open. Clear line-remove clog. 2C. Remove intake hose - poke eraser end of pencil into intake nozzle of pump to free check ball. 2D. Check all connections from intake thru-hull to intake pump to be sure no air leaks are present. 2E. See 1E, above. 2F. Replace impeller. 2G. Clean debris from strainer.
3. Foul odors from toilet area.	3A. "Marine life" lodged in rim of bowl. 3B. Permeated discharge hose 3C. Sewage remaining in discharge line. 3D. Concentrate reservoir empty.	3A. Remove and flush bowl with pressure hose to remove all material. Install strainer in intake line to avoid recurrence. Fill reservoir with Raritan Cleans Potties (#1PCP32) and use regularly. 3B. Replace hose with Raritan SaniFlex Hose (#SFH). 3C. Flush toilet longer; replace hose if permeated; reroute hose making a shorter run, if possible. 3D. Refill with 2 oz. (59ml) Raritan Cleans Potties (1PCP32) and water.
4. Bowl fills while underway.	4. Pressure buildup at seacocks.	4. Close intake, then discharge seacock to determine which is causing problem. If intake, replace check ball and spring. If discharge, be sure the vent or vented loop is clean. If intake, there is too much pressure on seacock; contact Raritan Technical Support.
5. Concentrate tank does not empty (or overflows).	5A. Check valve malfunctioning. 5B. Insufficient water flow from pump	5A. Remove and rinse check valve in warm water and rein-stall. Should problem continue, replace check valve. See page 7. 5B. Check waterflow and correct as needed.
6. Water leaking from under unit.	6A. Leaking bowl gasket. 6B. Leaking front cover. (#CH25) 6C. Leak at shaft seal.	6A. Tighten (4) bowl mounting nuts (#1226B). 6B. Remove front cover (#CH18) and inspect O"ring for damage. Replace "O" ring if necessary using Super Lube (#SL1CC) to reassemble. 6C. Check #CH59 seal and motor shaft.
7. Loud noises from unit.	7A. Object jammed in macerator. 7B. Motor bearings damaged by seal leak or other water source.	7A. Remove front cover and remove object. 7B. Return motor to factory for servicing or replacement.
8. Erratic operation/sluggish running	8A. Worn motor brushes. 8B. Motor bearings damaged by seal leak. 8C. Low or inconsistent voltage	8A. Return motor to factory for servicing or replacement. 8B. Return motor to factory for servicing or replace macerator seal. If bearings are bad, exchange lower base. 8C. See 1E above.

CROWN HEAD PARTS LIST

(Quantities are one unless otherwise indicated)

Before ordering, locate required part on exploded parts view to be sure you are ordering the correct part for your CROWN HEAD.

<u>Part No.</u>	<u>Description</u>	<u>Part No.</u>	<u>Description</u>
1118	Lockwasher (4)	F149VT	Set Screw (2)
1203B1	“O” Ring	G15	Impeller Washer (2)
1222AW	Discharge Ell and Flange	G13W	Pump Impeller Assembly w/(2) G15
1222B	Straight Discharge	G2M	Impeller Wear Plate
1222BW	Straight Discharge Assembly (Incl. 1222B, CH90, CH92, [2]1115, C253, [4]CH27)	M23A	Lockwasher (4)
1226B	Bowl Mounting Nut (4)	M30	Hex Nut, Brass (2)
1234	Bowl Gasket (fits all Raritan toilets)	M31	Flat Washer, Brass (2)
1341	Discharge Screw (2)	RNI	Nylon Bowl Mounting Washer (4)
31-102	Motor Shaft Seal	VCAP	Vinyl Cap (bowl nut cover)
C253	Joker Valve	MISCELLANEOUS RELATED PARTS	
CH102MW	Intake Pump Assembly, complete	<u>Part No.</u>	<u>Description</u>
CH119MW	Discharge Impeller Assy. (Incl. CH119M, [2] F149VT)	1236AW	Bowl Spud Assembly
CH12	Check Ball	1237W	Marine-size Bowl, Round Top Rim (white only), incl. 1236AW
CH120	Discharge Pump Wall	1238SC	Slow Close, Seat and Cover for Marine-size Bowl (white only)
CH121	Macerator	1244W	Household-style Bowl, Oval Top Rim available in white or bone, includes 1236AW
CH136	Siphon Cap for Shroud Bottle	1245SC	Seat and Cover for Household-style Bowl Slow Close
CH18W	Front Cover (w/“O” ring)	163000	In-Line Strainer
CH2	Pump Body (w/shaft seal)	CDS*	Continuous Duty Solenoid Relay
CH25	Front Cover “O” Ring	CHTT9	Hose Clamp for 1 1/2” I.D. Hose
CH26	Front Cover Screw (6)	1PCP32	Cleans Potties 32 oz.
CH27	Mounting Screw (4)	CSRK	Repair Kit (Centrifugal Discharge Series) Includes: CH25, CH92, 1234, CH12, G13, CH8, CH37E, RNI, CH120, C253, CH59, 31-102, CH7, G15, 1203B1 and CH57
CH291	Shroud (2 pcs.)	CDPUMPRK	Crown Head CD Series & CHII Intake Pump Repair Kit (built before 4/95) Includes: 1203B1, CH12, G13, G2M, 31-102, CH7 and G15
CH29A	Shroud Bottle (Concentrate Reservoir)	CDDISRK	Crown Head CD Series Discharge Repair Kit; Includes: 1234, CH120, CH57, CH92, C253, CH25 and CH59
CH29A1W	Shroud Assembly, Complete w/bottle, cap and siphon	CR1	Discharge Impeller and Macerator Assy. (incl. CH120, CH121, F149VT[2], and CH119MW)
CH336W	Siphon Assembly, Complete (Incl. CH136, CH37, CH37E)	PRS	Momentary Flush Switch
CH34	Woodruff Key	RTCH24DA	Rectified Transformer (for 120 or 240 VAC input)
CH37	Siphon Tubing	SFH	Saniflex Hose 1 1/2”
CH37E	Siphon Check Valve	SL1CC	Super-Lube 1/2 oz. tube
CH38	Bowl Stud (4)		
CH42	Hose		
CH43	S/S Hose Clamp (2)		
CH5VW	Pump Plug, Vented(Incl. 1203B1 O Ring)		
CH50CW	Bowl Elbow w/Siphon Intake		
CH51	Base Screw (4)		
CH52	Rubber Mounting Strip (2) not shown		
CH53	Pump Mounting Screw (4)		
CH55A	Base Plate		
CH57	Slinger		
CH58	End Bell Screw (4)		
CH59	Seal with Stainless Steel Spring		
CH6	Pump Cover Plate		
CH7	Pump Gasket		
CH8	Check Valve Spring		
CH90	Discharge Adapter		
CH92	Adapter Gasket		
CHM*	Motor		

*Specify Voltage

crown head

EXPLODED PARTS VIEW

CENTRIFUGAL DISCHARGE SERIES

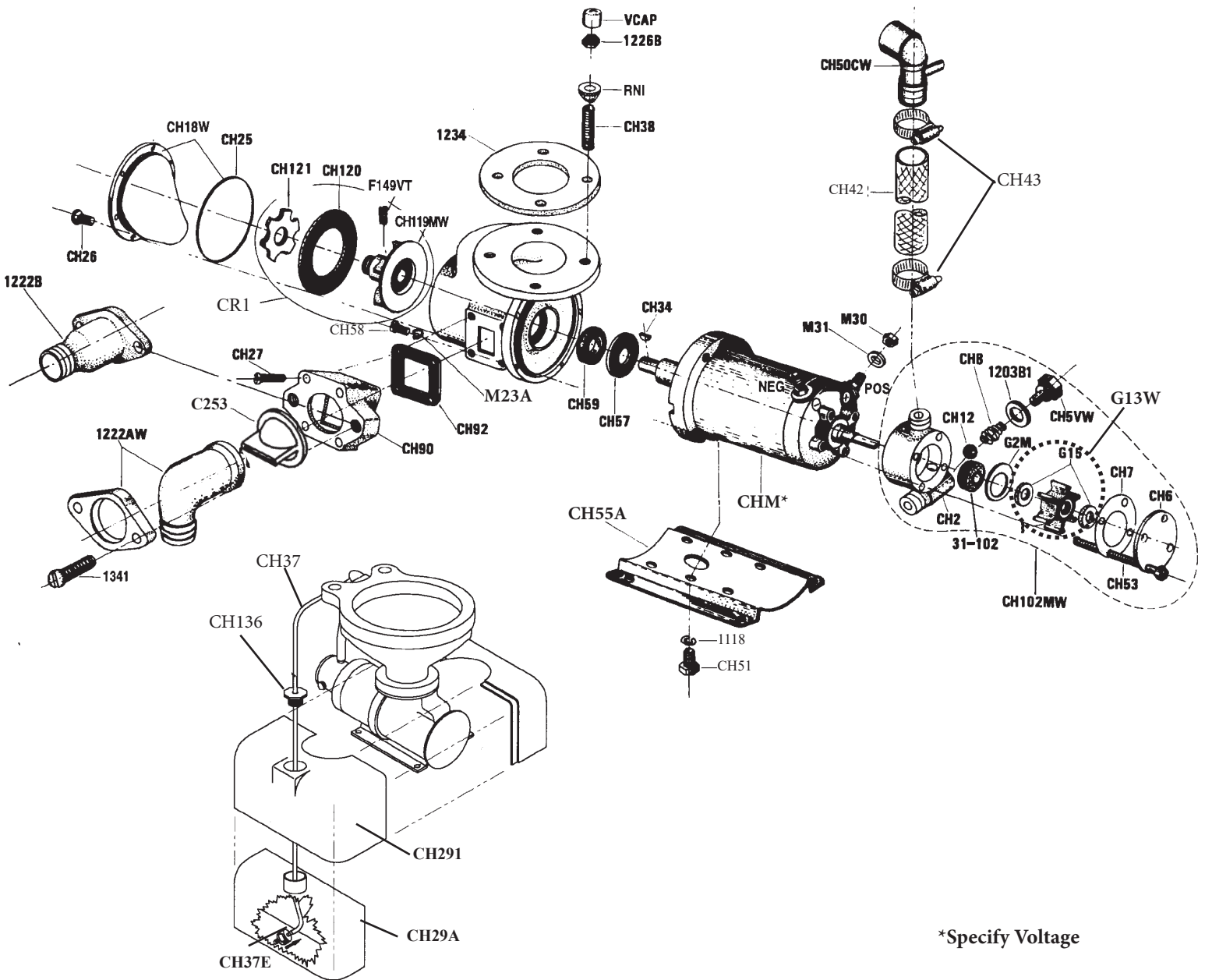

LIMITED WARRANTY

Raritan Engineering Company warrants to the original purchaser that this product is free of defects in materials or workmanship for a period of one year from the product's date of purchase. Should this product prove defective by reason of improper workmanship and/or materials within the warranty period, Raritan shall, at its sole option, repair or replace the product.

1. TO OBTAIN WARRANTY SERVICE, Consumer must deliver the product prepaid, together with a detailed description of the problem, to Raritan at 530 Orange St., Millville, N.J. 08332. When requesting warranty service, purchaser must present a sales slip or other document which establishes proof of purchase. THE RETURN OF THE OWNER REGISTRATION CARD IS NOT A CONDITION PRECEDENT OF WARRANTY COVERAGE. However, please complete and return the owner Registration Card so that Raritan can contact you should a question of safety arise which could affect you.
2. THIS WARRANTY DOES NOT COVER defects caused by modifications, alterations, repairs or service of this product by anyone other than Raritan; defects in materials or workmanship supplied by others in the process of installation of this product; defects caused by installation of this product other than in accordance with the manufacturer's recommended installation instructions or standard industry procedures; physical abuse to, or misuse of, this product. This warranty also does not cover damages to equipment caused by fire, flood, external water, excessive corrosion or Act of God.
3. ANY EXPRESS WARRANTY NOT PROVIDED HEREIN, AND ANY REMEDY FOR BREACH OF CONTRACT WHICH BUT FOR THIS PROVISION MIGHT ARISE BY IMPLICATION OR OPERATION OF LAW, IS HEREBY EXCLUDED AND DISCLAIMED. ALL IMPLIED WARRANTIES SUCH AS THOSE OF MERCHANTABILITY AND OF FITNESS FOR A PARTICULAR PURPOSE, IF APPLICABLE, AS WELL AS ANY IMPLIED WARRANTIES WHICH MIGHT ARISE BY IMPLICATION OF LAW, ARE EXPRESSLY LIMITED TO A TERM OF ONE YEAR. SOME STATES DO NOT ALLOW LIMITATIONS ON HOW LONG A LIMITED WARRANTY LASTS, SO THE ABOVE LIMITATION MAY NOT APPLY TO YOU.
4. UNDER NO CIRCUMSTANCES SHALL RARITAN BE LIABLE TO PURCHASER OR ANY OTHER PERSONS FOR ANY SPECIAL OR CONSEQUENTIAL DAMAGES, WHETHER ARISING OUT OF BREACH OF WARRANTY, BREACH OF CONTRACT, OR OTHERWISE. SOME STATES DO NOT ALLOW THE EXCLUSION OR LIMITATION OF INCIDENTAL OR CONSEQUENTIAL DAMAGES, SO THE ABOVE LIMITATION OR EXCLUSION MAY NOT APPLY TO YOU.
5. No other person or entity is authorized to make any express warranty, promise or affirmation of fact or to assume any other liability on behalf of Raritan in connection with its products except as specifically set forth in this warranty.
6. This warranty gives you specific legal rights, and you may also have other rights which vary from state to state.



530 Orange Street, Millville, NJ 08332 USA
Telephone: 856-825-4900 FAX: 856-825-4409
www.raritaneng.com