

MANAGERM

Model 640012* Type II Marine Sanitation Device

MAINTENANCE AND INSTALLATION INSTRUCTIONS

THE FOLLOWING ARE CAUTIONARY STATEMENTS THAT MUST BE READ AND FOLLOWED DURING BOTH INSTALLATION AND OPERATION.

WARNING: *Raritan Engineering Company, Inc. recommends that a qualified person or electrician install this product. Equipment damage, injury to personnel or death could result from improper installation. Raritan Engineering Company, Inc. accepts no responsibility or liability for damage to equipment, injury or death to personnel that may result from improper installation or operation of this product.*



WARNING: HAZARD OF SHOCK OR FIRE



Always use recommended fuse, circuit breaker and wire size.

This device must not be installed in an explosive environment.

WARNING: HAZARD OF FLOODING - Always shut off seacock(s) before leaving the boat unattended. Double clamp all below waterline hose fittings and check frequently for integrity.

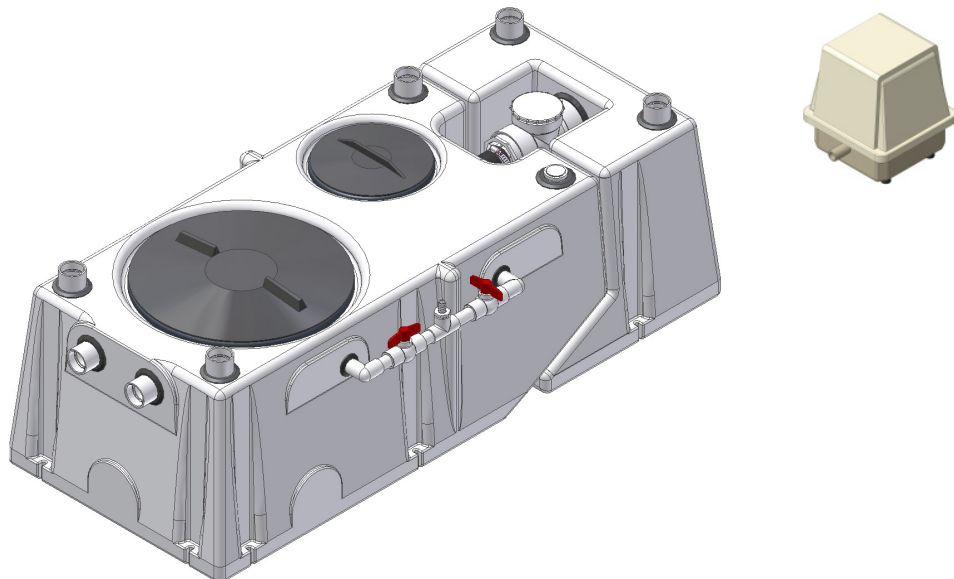

The **MANAGERM** is a U.S. coast Guard certified Type II Marine Sanitation Device (MSD) for inspected and uninspected vessels.



RARITAN

The Most Dependable Name on the Water

1-800-352-5630

www.raritaneng.com

IMPORTANT: Understanding how your system functions and maintaining it properly will give you odor-free use for many years. The system is designed for human waste and toilet tissue only.

The **MANAGerM** is a U.S. coast Guard certified Type II Marine Sanitation Device (MSD) for inspected and uninspected vessels. The **MANAGerM** may be used in fresh, brackish or salt water. If using the **MANAGerM** on an inspected vessel, all the provisions of 46CFR, subchapters F. and J. must be followed.

The **MANAGerM** is a flow through system for black water only. It is an extended aeration bioreactor with a secondary disinfecting tank.

The **MANAGerM** has two tanks. The first tank has two chambers - the first chamber converts waste into water (H₂O) and carbon dioxide (CO₂) - the second chamber allows solids to settle and clarified water to pass on to the secondary tank.

Water displaced from the first tank moves through the tablet dispenser and into the secondary tank where disinfection takes place.

The **MANAGerM** works best with macerating and eductor (jet-type) toilets.

The **MANAGerM** is recommended for installations at or above the waterline of the boat

NOTE:

For installation below waterline, see page 14.

IMPORTANT

- **The System must be completely filled with water before use**
- **Flush Only Human Waste and Toilet Paper into the System**
- **Maintenance schedule must be closely followed.**
- **Use Only Recommended Cleaning Products in your Toilet**
- **Do Not Flush Cigarettes, Paper Towels, feminine hygiene products, handi-wipes, grease, oils, disinfectant cleaners (bleach/chlorine/acidics) or condoms down the toilet**
- **Do not exceed system capacity**
- **Keep unit from freezing**
- **Air pump must be in operation at all times (except when system is winterized)**
- **If using the system year around, periodic pumpout via a shore based facility is recommended.**

Types of Toilet Tissue to Use

It is not necessary to use toilet tissue that is “biodegradable”; however, we recommend using only toilet tissue that dissolves quickly in water.

To determine if a particular brand of toilet tissue is suitable for your treatment system: Place a sheet of the toilet tissue in a glass of water overnight. If in the morning, it is still intact or partially intact the tissue is not suitable. If the tissue has come apart, the tissue is suitable. Typically, single-ply toilet tissue works fine.

Optimal Operating Temperatures:

Although the **MANAGerM** will operate at temperatures between 40° and 120° F. (4.5° and 49° C.), optimal temperatures are between 60° and 115° F. (15.5° and 46° C.). The **MANAGerM** uses live bacteria to break down and liquify waste inside the tank. As temperatures go below 60° F. or above 115° F. (15.5° and 46° C.) less than optimum treatment will occur.

TOILET CLEANING

IMPORTANT: Use only biodegradable cleaning and deodorant products in the toilet(s) connected to the **MANAGerM**. Do not use non-biodegradable cleaning products or cleaning products that contain bleach, chlorine, antibacterial, acids, pine oil, caustics, or any products that will kill bacteria. The use of these products will kill the bacteria necessary for the **MANAGerM** to operate properly and will require that the system be flushed, cleaned and re-started (see Startup Procdeure).

Using C.P. (#1PCP22), a bio-emzymatic toilet bowl cleaner (available from Raritan Engineering), will keep the bowl clean and fresh smelling.

EPA Statement

The EPA standards state that in freshwater lakes, freshwater reservoirs or other freshwater impoundments whose inlets or outlets are such as to prevent the ingress or egress by vessel traffic subject to this regulation, or in rivers not capable of navigation by interstate vessel traffic subject to this regulation, marine sanitation devices certified by the U.S. Coast Guard installed on all vessels shall be designed and operated to prevent the overboard discharge of sewage, treated or untreated, or of any waste derived from sewage. The EPA standards further state that this shall not be construed to prohibit the carriage of Coast Guard-certified flow-through treatment devices which have been secured so as to prevent such discharges. They also state that waters where a Coast Guard-certified marine sanitation device permitting discharge is allowed include coastal waters and estuaries, the Great Lakes and interconnected waterways, freshwater lakes and impoundments accessible through locks, and other flowing waters that are navigable interstate by vessels subject to this regulation (40 CFR 140.3).

MAINTENANCE

- Every week check tablet dispenser and add tablets if needed.
- Every two weeks, flush 2 oz. of Raritan K.O. into system through the toilet.
- Every month, open agitator valve for 5 minutes.
- Every two months clean aerator pump filter.
- If using the system year around, periodic pumpout via a shore based facility is recommended.

Checking Tablet Dispenser

1. Unscrew Dispenser Lid.
2. Check level of tablets
3. Add tablets if needed.

IMPORTANT: Do not allow system to operate without Tablets. Untreated sewage may be discharged.

CAUTION: Tablets are a hazardous material. Handle with care. Refer to the Material Safety Data Sheet for complete safety information.

WARNING: Tablets may be fatal if swallowed. Tablet dust may be irritating to eyes, nose and throat. Wear rubber gloves and either safety goggles or a face shield when handling tablets. Keep out of reach of children. Store tablets only in original container in a cool, dry, well ventilated area away from flames or heat. Avoid water contamination. Refer to the Material Safety Data Sheet for complete safety information.

CAUTION: Tablets are highly corrosive, contact with other chlorine products, reducing agents or dechlorination chemicals is extremely dangerous. Fire or explosion could result.

Do Not use other products in place of tablets supplied. **Do not** mix with other chlorine products or tablets.

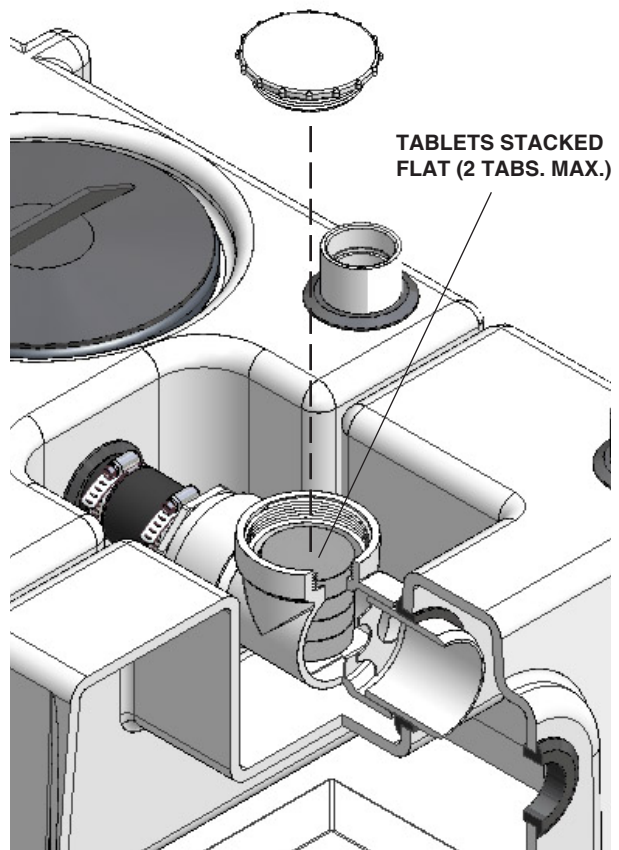

Cleaning Upflow Filter (monthly)

1. Open Agitator Valve
2. Close Diffuser Valve
3. Wait 5 minutes
4. Open Diffuser Valve
5. Close Agitator valve

Note: After cleaning upflow filter, wait 15 minutes before flushing toilet.

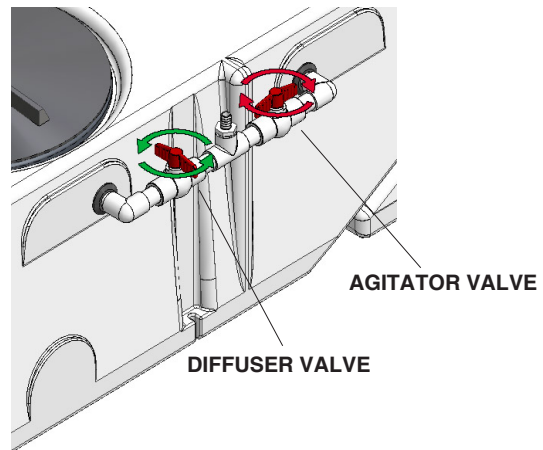
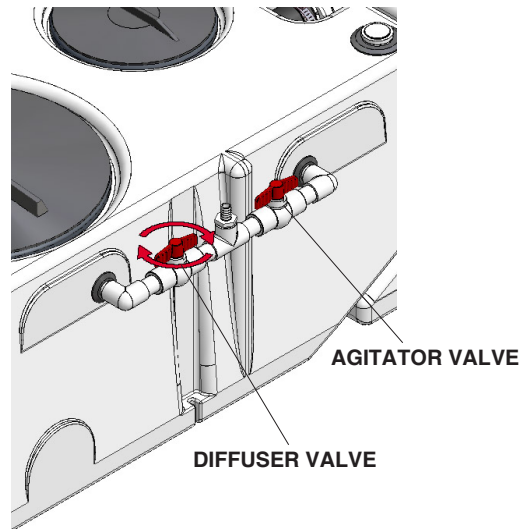
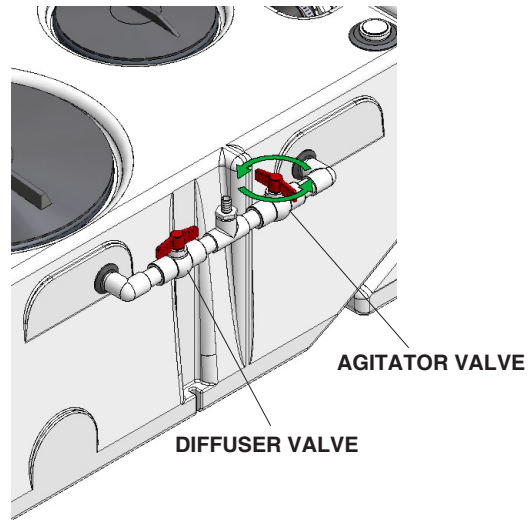

VALVE (Open Position)

VALVE (Closed Position)

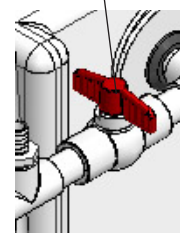
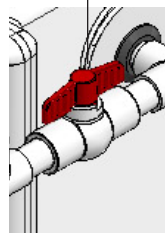

Cleaning Aerator Pump Filter (every 2 months)

1. Disconnect power (unplug pump)
2. Follow filter cleaning instructions on instruction sheet included with Aerator Pump

Pumpout Information.

Both tanks will need to be pumped out at the following times:

- End of each boating season during the winterizing process
- If system is used year around, annual pumpout is recommended.
- If system becomes contaminated with bacteria killing agents
- If system becomes clogged by overuse or addition of foreign objects.

Both tanks cannot be pumped out simultaneously. The secondary tank being smaller, will empty first, causing the pump to draw air. The two tank pumpouts must be mechanically isolated from one another via valving during initial installation.

Pump out one tank at a time via dockside facility. Note: When pumping out primary tank, rinse with water until water being removed is clear.

After pumping out the two tanks, repeat Startup Procedure.

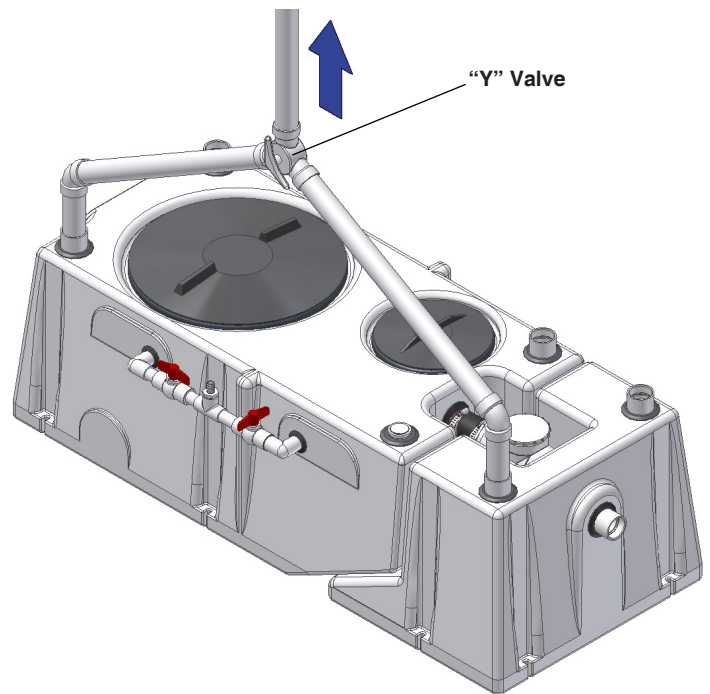

Short Term Storage - longer than 2 weeks. (for up to 2 weeks of non-use, system may be left as-is)

1. Flush toilet system with fresh water.
 2. Leave aerator pump running.
 3. Once a week, flush five gallons of water into system.
- Important:** Failure to follow this procedure may cause the system to go septic (anaerobic), creating foul odors.

Winterizing/Dry Storage (long term storage - more than 2 months)

1. Flush toilet several times to clear any waste from lines.
2. Shut off any valves between toilet and **MANAGerm**.
3. Pump out system. Rinse both tanks until only clear water is being pumped out.
4. Turn off power (unplug) to aeration pump.

START UP

1. Unscrew Dispenser lid, then fill tablet dispenser with tablets (stack 2 tablets flat inside dispenser) - top figure on right.
2. Remove large inspection lid (64102) and fill system with water until it is being discharged from system. Replace large inspection lid (64102) - center figure on right.
3. Add 1 ½ oz (42.5 grams) of startup enzyme (½ bottle) to one gallon (3.785 LITERS) of cold or lukewarm water - bottom figure on right.

CAUTION: Hot water above 120° F. (49° C.) will destroy bacteria.

4. Flush solution down toilet into system.
5. Turn on aerator pump.

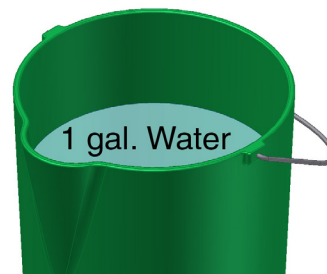
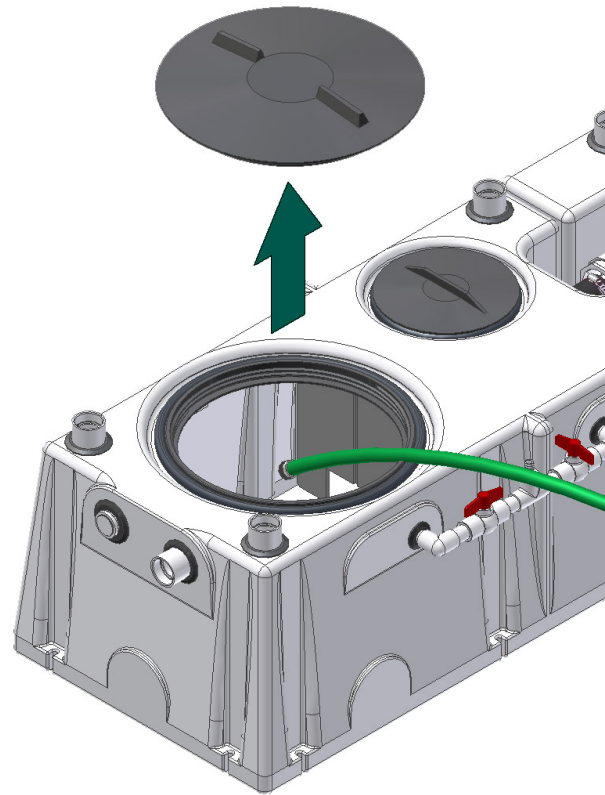
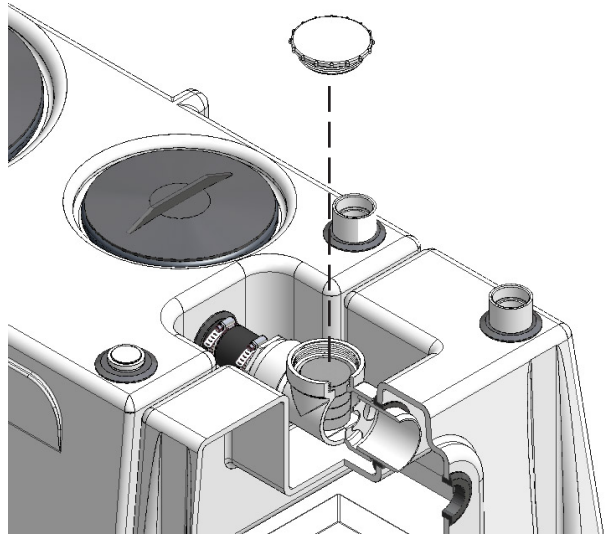

SPECIFICATIONS

Parts Included

Aerator Pump
Primary Tank
Secondary Tank
Raritan K.O.
Tablets
Startup Enzyme
Air Hose

Parts Required

3/8" Mounting screws or bolts (10)
3/8" Flat Washers (10)
Plumbing Fittings
1 1/2" Schedule 40 PVC pipe
1 1/2" PVC Fittings (depending on installation requirements)
1 1/2" Sanitation Hose
1 1/2" Stainless Steel Hose Clamps
AC GFCI circuit interrupter
1 1/2" through-hull fittings (for vents and discharge hose).
Deck Pumpout Fittings

General Specifications

Treatment Capacity

Model 640012* - 12 persons/day - 60 gallons (227 liters) per day.

* Voltage 1 for 120v, 2 for 240v

Maximum Pitch and Roll Angle 15 degrees

Water Requirements - fresh, brackish or salt water. Salt content of water not to exceed 4% (40 PPT).

Weight Dry - 100 lb (45 kg)
Wet - 575 lb (260 kg)

Electrical

120 VAC 50w 60 HZ aerator pump or
240VAC 50w 50HZ aerator pump
- use GFCI protected outlet on 5 amp. breaker.

Plumbing

Pressure max. 3 psi (21 kPa) (7 ft H2O)
Maximum ht below waterline __ 10 Feet

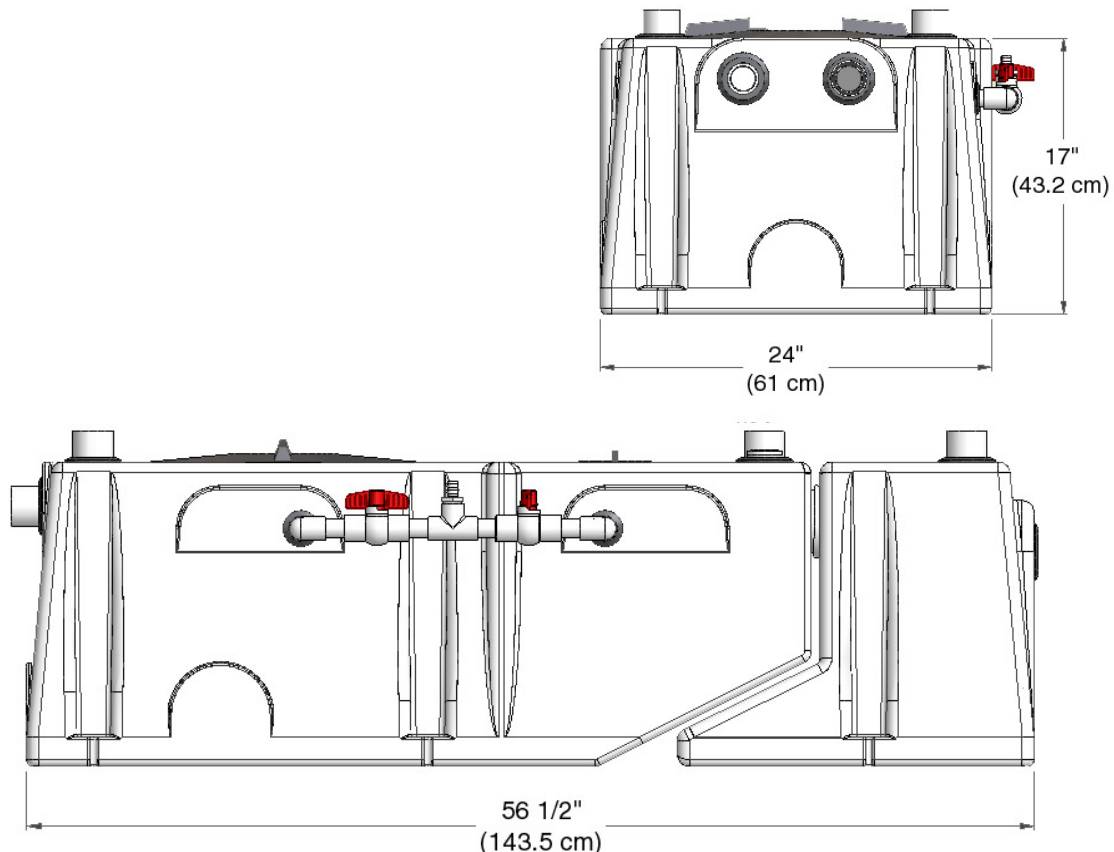

The **MANAGerm** is approved for installation on inspected vessels provided that plumbing and electrical connecting the unit are in compliance with U.S.C.G. marine engineering and electrical regulations, 46 CFR, Subchapters F. and J.. For further information on Inspected Vessel Requirements contact your local U.S.C.G. inspector or: Commandant G-MSE-3, United States Coast Guard, System Engineering Division, 2100 Second Street, S.W., Washington, DC 20593-0001

Location

- Install on a flat and level surface.
- Mounting surface must support weight of unit when filled with water.
- System should be oriented fore and aft (lengthwise on boat).
- Mounting area must be well ventilated
- Install on a surface at or above the waterline
- Temperatures must not exceed 120° F.
- Must have access for maintenance
TIP: Mount where tablet dispenser can be accessed via a deck hatch for convenience.

Mounting

1. At mounting location, slide tanks together while attaching the coupling to the dispenser.
2. Secure Tanks to deck using 3/8" Bolts or Screws. Note: type of fasteners will depend on the deck material, thickness and access.

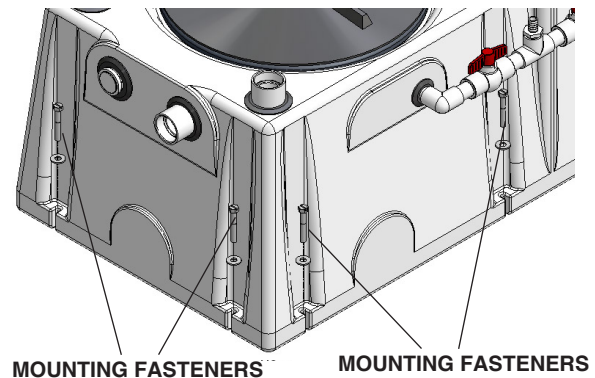
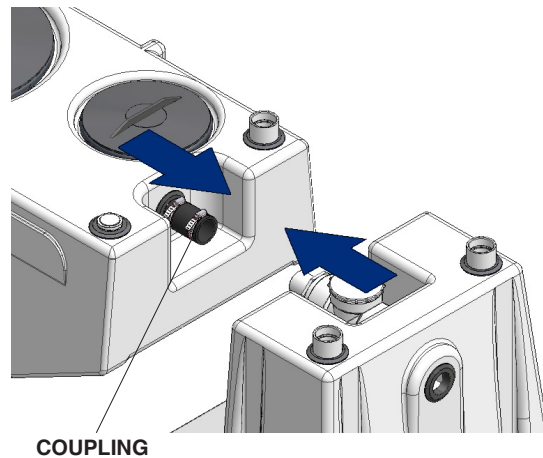
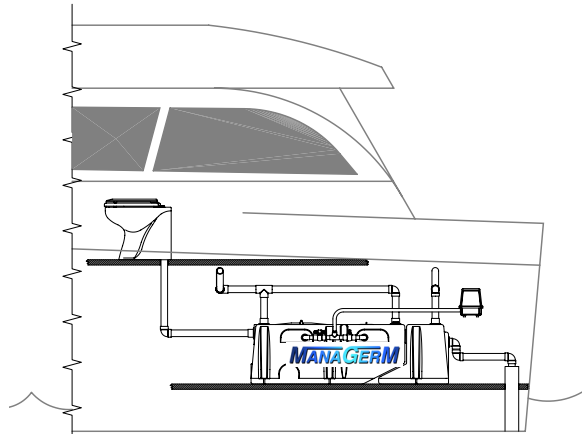

INSTALLATION

Plumbing

SEE Page 14 for below water installation

- 1 1/2" Schedule 40 PVC fittings are used exclusively on the **MANAGerm**.
- Support plumbing in a manner to insure that weight of the plumbing is not carried by the tank or its fittings.

1. Connect discharge of each toilet to appropriate inlet fitting on **MANAGerm**.
2. If only one toilet is being used, glue plug into vacant inlet port.
3. Connect discharge of **MANAGerm** to overboard through hull fitting..

Note: Discharge line must be a downward run to the through hull; no portion of the piping/hose must be higher than discharge port of secondary tank.

Installing Pumpout Fittings

1. Pumpout fittings should be connected to appropriate pumpout ports on top of each tank, then run to a "Y" valve.
2. From the "Y" valve, hose is run to deck pump out fitting.
3. Install "Y" valve so that port going to deck pumpout is the "common" port and the two other ports run to the vent fittings on the respective tanks. this allows each tank to be selected individually for pumpout.

OPTIONAL: Each tank may be directly plumbed to independant deck pump-out fittings.

Installing Vents

Venting the system is important for proper operation. Vent fittings are located on top of tanks.

IMPORTANT

- Vents must be minimum of 1 1/2" pipe or hose.
- Vent lines exiting unit should be vertical as much as possible but not greater than 20" (50 cm.) above tank(s).

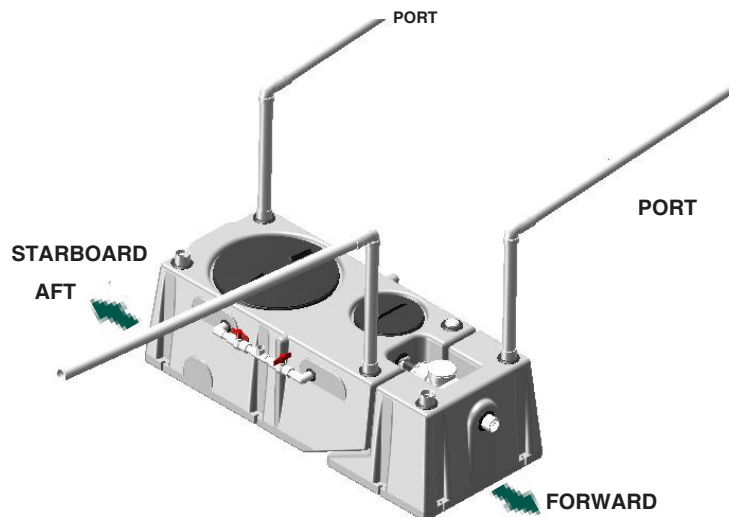
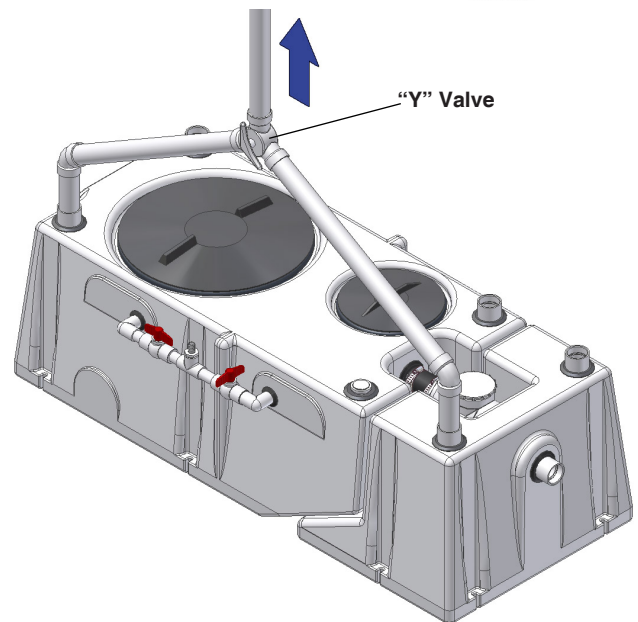
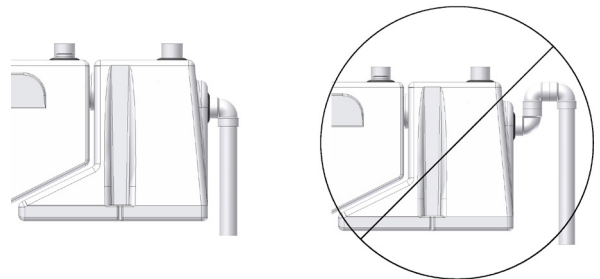
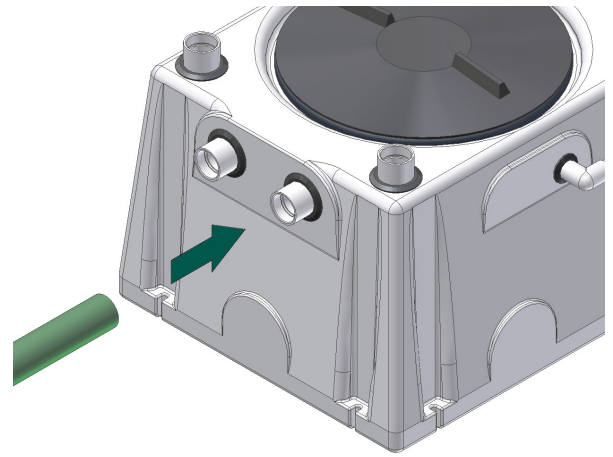

- Unit should be cross-vented to port and starboard.
- Do not vent into a confined space onboard.
- Vents must not have sags, loops or obstructions where water can collect, restricting air flow.
- Vent lines should be sloped to allow condensation to drain from vents into tanks.
- Although a properly operating system should not have odors, do not locate vent through-hull fittings near galley, sleeping or high use areas.

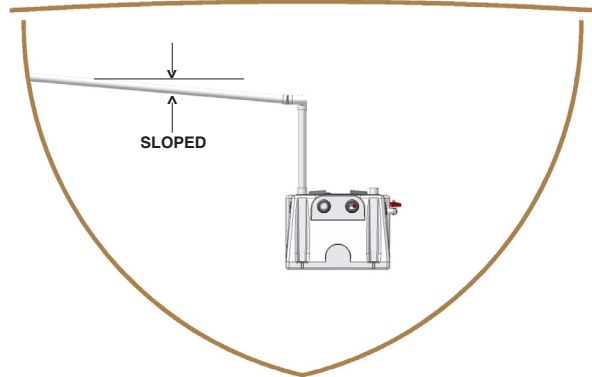

Secondary tank should be vented separately from primary tank to prevent primary tank from chlorine contamination.

Installing Aerator Pump

⚠ WARNING: Not certified for use in an explosive environment.

- Install Aerator Pump above tank in a secure area.
- Install in a well ventilated area. Aerator Pump must have fresh air available.
- Install within 6 feet (2 meters) of fitting on primary tank.
- Receptacle to plug in pump must be GFCI (ground fault circuit interrupter) protected with 5 Amp circuit breaker.

1. Connect 1/2" hose to Aerator Pump.
2. Connect 1/2" hose to fitting on primary tank.
3. Make sure diffuser and agitator valves are in correct position(s).
4. Plug aeration pump into GFCI receptacle. If hard-wiring, be sure to follow all appropriate regulations and codes.

Proceed to Start Up Section of Manual

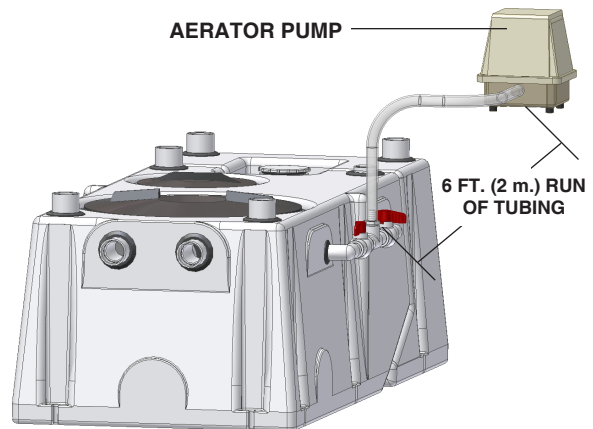
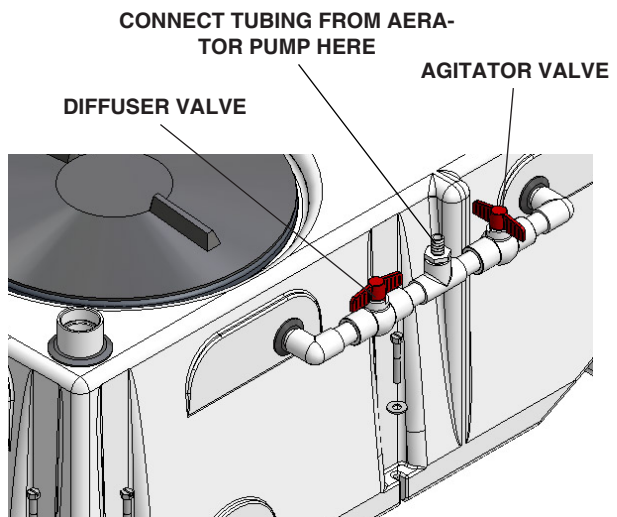

EXPLODED PARTS

MANAGERM - Parts List

Part #	Description
640101	Primary Treatment Tank Assembly
640102	Manway Lid, 16"
640103	Ring/C Gasket, 16"
640104	Manway Lid, 8"
640105	Ring/C Gasket, 8"
640111	Filter Brush (3) - [Not shown]
F171	Screw, #8-32 x 3/4" Plastite, 18-8 black (14)
640116	Dispenser
PLCF1-5	1½" Flex Coupling
PLCAP3-0W	Dispenser Cap, w/"O" Ring
640201	Secondary Tank Assembly
1PKO22	K.O. - Kills Odor, 22 oz.
640121	Startup Enzymes, 12-B Count Sewage Enzyme, 3 oz.
6401120	Air Pump, 120 VAC
6401240	Air Pump, 240V
640143	Air Hose, Clear PVC, 5/8" I.D. x 3/4" O.D.
640205	Blue Crystel Tablets (not shown)
640130	Air Pump Filter
640135	Air Pump Repair Kit
Parts for below water kit (not shown)	
64B2120	Pump 115V
64B2240	Pump 240 V
64BF120	Float switch 120/240V
VL3/4	3/4" vented loop

EXPLODED PARTS

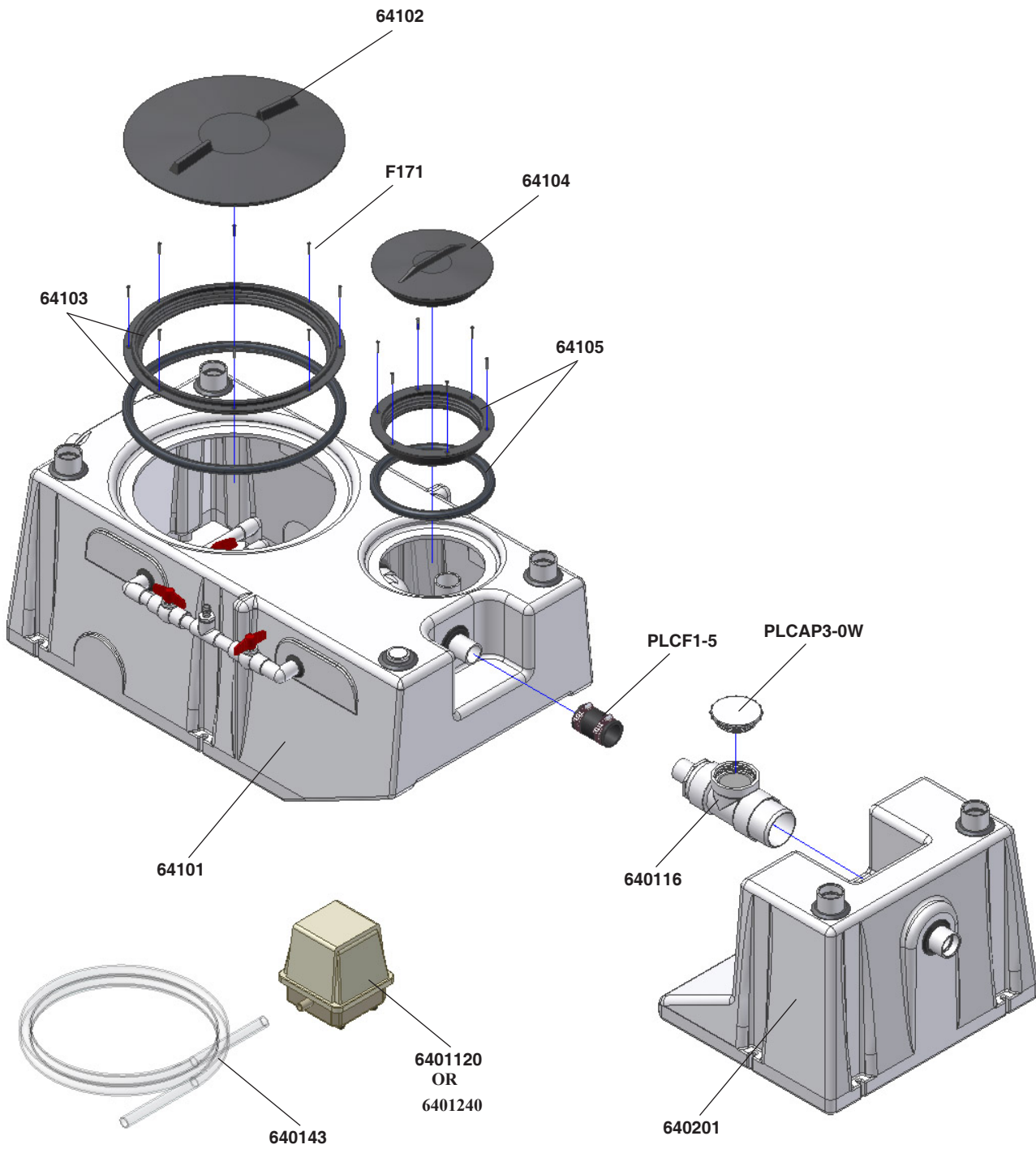

UNITS WITH PUMP UP KIT FOR BELOW WATER LINE INSTALLATION

Parts Included

Pump
Float switch (installed)
Tank fitting (installed)
Vented loop
Various fittings

Parts not Included but needed

3/4" PVC hose
3/4" thru-hull fitting

Plug converter for 240V plugs

PLUMBING:

1. Install discharge pump at the same level as bottom of the tank 2 close to tank, secure using mounting feet.

WARNING: This pump is not ignition protected. DO NOT install in compartments containing gasoline tanks or in areas in which ignition protected equipment is required.

2. Install thru-hull 3/4" fitting with shutoff valve. Do not use Nylon fittings as it can have adverse effect with chlorinated discharge.

3. Install vented loop

NOTE: The top of the vented loop must be a minimum of 4" (10cm) above the waterline at

the boats greatest angle of heel

3. plumb between tank bottom fitting and pump using hose clamps

4. Plumb between pump discharge fitting and vented loop. and between vented loop and thru-hull shutoff valve

5. Secure all connection with clamps.

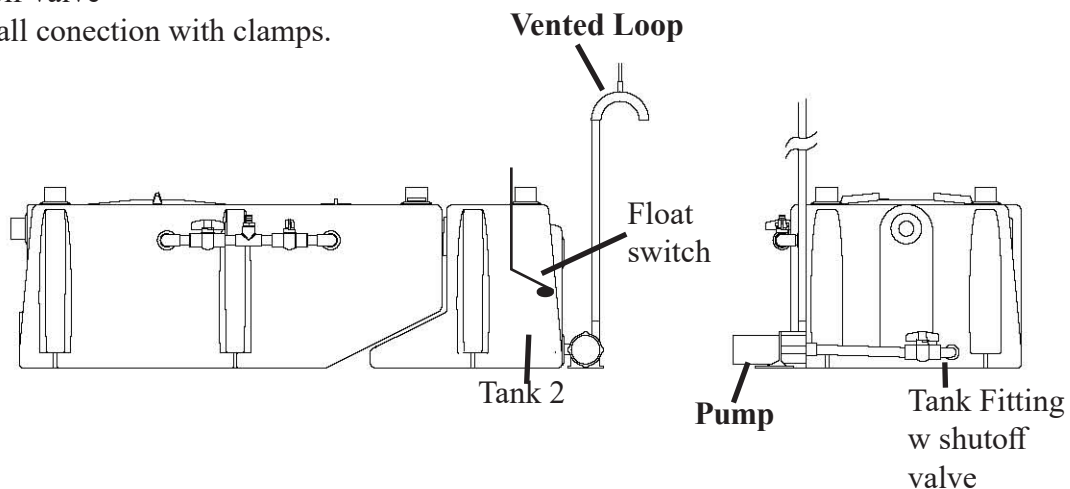
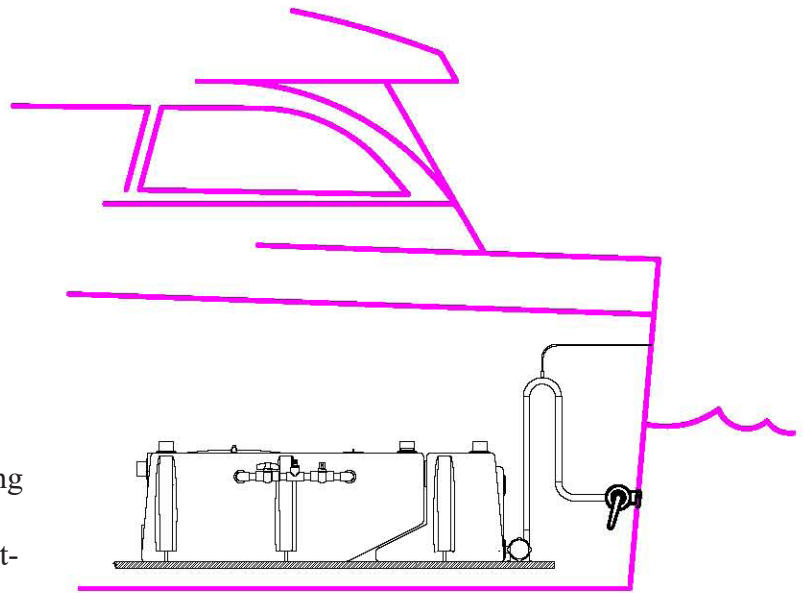

Wiring:

120 V units:

1. Plug float switch into a GFCI outlet.
2. Plug pump plug into float switch plug.
Do not plug pump directly into outlet, pump has to be controlled by float switch

240V unit:

1. Plug pump plug into float switch plug.
Do not plug pump directly into outlet, pump has to be controlled by float switch, and
2. Using plug converter for USA to country in which system is installed, plug float switch into the outlet.
OR

Using wiring diagram as shown, hard wire pump and float switch to the power supply.

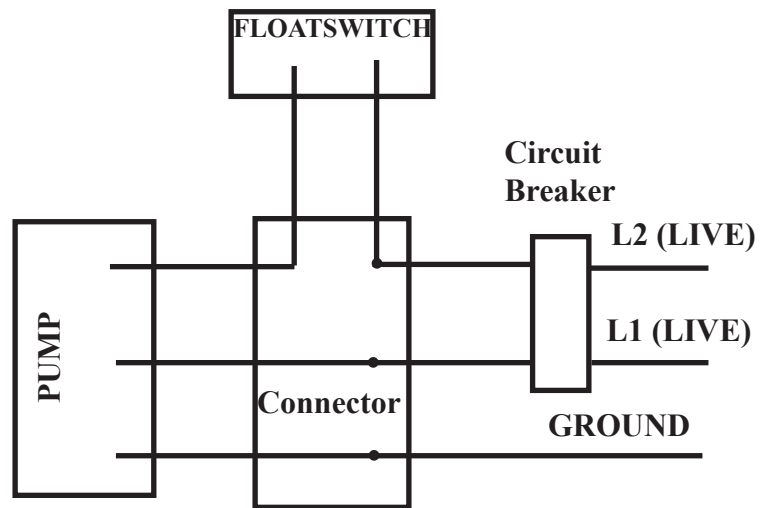
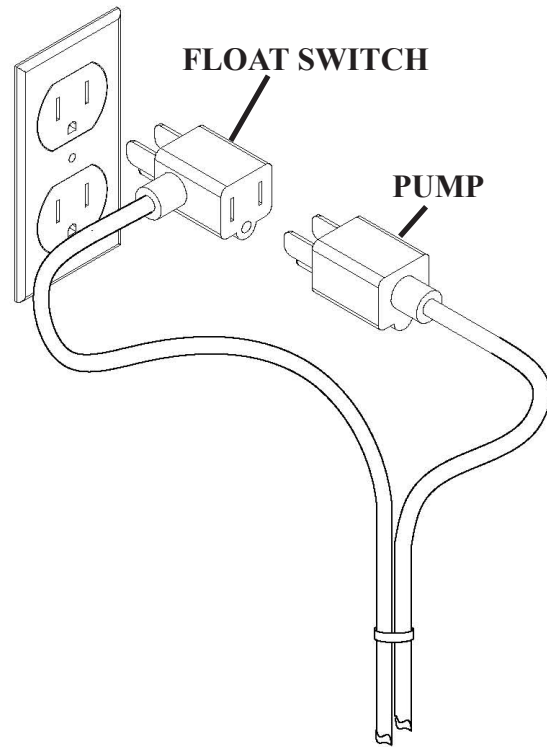

Direct Wiring

LIMITED WARRANTY

Raritan Engineering Company warrants to the original purchaser that this product is free of defects in materials or workmanship for a period of one year from the product's date of purchase. Should this product prove defective by reason of improper workmanship and/or materials within the warranty period, Raritan shall, at its sole option, repair or replace the product.

1. TO OBTAIN WARRANTY SERVICE, Consumer must deliver the product prepaid, together with a detailed description of the problem, to Raritan at 530 Orange St., Millville, N.J. 08332. When requesting warranty service, purchaser must present a sales slip or other document which establishes proof of purchase. THE RETURN OF THE OWNER REGISTRATION CARD IS NOT A CONDITION PRECEDENT OF WARRANTY COVERAGE. However, please complete and return the owner Registration Card so that Raritan can contact you should a question of safety arise which could affect you.
2. THIS WARRANTY DOES NOT COVER defects caused by modifications, alterations, repairs or service of this product by anyone other than Raritan; defects in materials or workmanship supplied by others in the process of installation of this product; defects caused by installation of this product other than in accordance with the manufacturer's recommended installation instructions or standard industry procedures; physical abuse to, or misuse of, this product. This warranty also does not cover damages to equipment caused by fire, flood, external water, excessive corrosion or Act of God.
3. ANY EXPRESS WARRANTY NOT PROVIDED HEREIN, AND ANY REMEDY FOR BREACH OF CONTRACT WHICH BUT FOR THIS PROVISION MIGHT ARISE BY IMPLICATION OR OPERATION OF LAW, IS HEREBY EXCLUDED AND DISCLAIMED. ALL IMPLIED WARRANTIES SUCH AS THOSE OF MERCHANTABILITY AND OF FITNESS FOR A PARTICULAR PURPOSE, IF APPLICABLE, AS WELL AS ANY IMPLIED WARRANTIES WHICH MIGHT ARISE BY IMPLICATION OF LAW, ARE EXPRESSLY LIMITED TO A TERM OF ONE YEAR. SOME STATES DO NOT ALLOW LIMITATIONS ON HOW LONG A LIMITED WARRANTY LASTS, SO THE ABOVE LIMITATION MAY NOT APPLY TO YOU.
4. UNDER NO CIRCUMSTANCES SHALL RARITAN BE LIABLE TO PURCHASER OR ANY OTHER PERSONS FOR ANY SPECIAL OR CONSEQUENTIAL DAMAGES, WHETHER ARISING OUT OF BREACH OF WARRANTY, BREACH OF CONTRACT, OR OTHERWISE. SOME STATES DO NOT ALLOW THE EXCLUSION OR LIMITATION OF INCIDENTAL OR CONSEQUENTIAL DAMAGES, SO THE ABOVE LIMITATION OR EXCLUSION MAY NOT APPLY TO YOU.
5. No other person or entity is authorized to make any express warranty, promise or affirmation of fact or to assume any other liability on behalf of Raritan in connection with its products except as specifically set forth in this warranty.
6. This warranty gives you specific legal rights, and you may also have other rights which vary from state to state.



530 Orange Street, Millville, NJ 08332 USA
Telephone: 856-825-4900 FAX: 856-825-4409
www.raritaneng.com

Fort Lauderdale, FL
Telephone: 954-525-0378