

Icerette

AUTOMATIC ICE CUBE MAKER

INSTALLATION, OPERATION, MAINTENANCE AND TROUBLESHOOTING

WARNING: *Raritan Engineering Company, Inc. recommends that a qualified technician install, troubleshoot and repair this product. Equipment damage, injury to personnel or death could result from improper installation. Raritan Engineering Company, Inc. accepts no responsibility or liability from damage to equipment, or injury or death to personnel that may result from improper installation of this product.*



WARNING: Refrigeration Equipment contains refrigerant fluids under very HIGH PRESSURE. Danger of sudden pressure release may cause injury, death or severe frostbite resulting from not following instructions.



CAUTIONS: DO NOT plug a 120 volt unit into a 240 volt power source.



DO NOT plug a 240 volt unit into a 120 volt power source.

DO NOT use a transformer to step down 240 volt 50 HZ power supply to 120 volt.

Equipment designed for 60 HZ may run slow on 50 HZ, resulting in inferior operation and possible overheating of the motor(s).

WARNING: This device is not ignition protected. DO NOT install in compartments containing gasoline tanks or in areas in which ignition protected equipment is required.



INTRODUCTION

Model 84 and 85 Icer-ettes are CFC-Free automatic icemakers designed and manufactured especially for the marine environment. They produce up to 22 lbs (10kg) of crescent shaped ice per day and can store 11 lbs (5kg). Model 84 is designed for installations where less than counter height is available and the 85 is designed for counter height installations. Each model has a flush mount option which prevents the door from extending beyond the cabinets. Installation and maintenance are simple because no drain is required and the thermostat is fixed; never needing adjustment.

OPERATION

The Icer-ette's on-off switch is just beneath the door. A unit begins to produce ice within 60 minutes after start-up. Ice production stops automatically when the bucket is full enough to interfere with the wire shut-off arm. The unit should not be turned "off" with the door closed and ice or water inside.

NOTES:

1. **Due to fast freezing, ice cubes may appear "cloudy". This is trapped air in the water and does not affect the taste or quality of the ice.**
2. **"Hollow" ice cubes may result from fast-freezing under certain climatic conditions such as high humidity, etc. and is not an indication of a problem with the icemaker.**

MODEL 85



MODEL 84

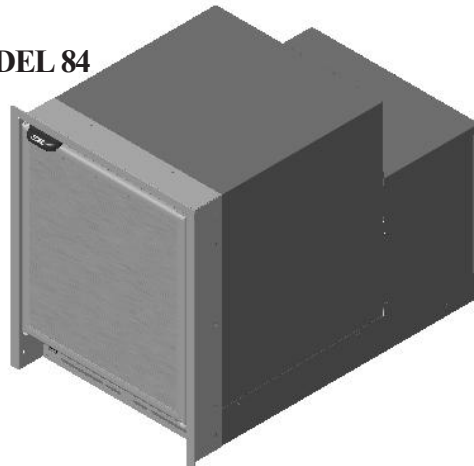

MAINTENANCE

- √ Periodically vacuum dust and dirt from the condenser, located behind the grille at the bottom front of the unit.
- √ Regularly inspect plumbing connections to insure that no leaks are present.

When necessary, defrost and thoroughly clean the inside of the unit with mild soap and water. **Do not use electrical heating devices, sharp or pointed tools when defrosting.**

When defrosting or leaving the unit turned off, prop and leave the door open using door prop. This allows air to dry the inside of the cabinet, reducing the chance for mildew and damage to the mold mechanism's components.

WINTERIZING

WARNING: Disconnect power at source before working on the unit. Do not winterize this unit with ANY type of anti-freeze; damage to the mold coating will occur, invalidating product's Limited Warranty and creating potential health hazard.

1. Shut off the water supply to the unit.
2. Disconnect as follows:

Model 85: Disconnect water supply connector behind front grille at solenoid valve (garden hose connector). Remove white plastic tubing and nut from bottom of solenoid valve.

Model 84: Disconnect the in-line water supply connector behind the front grille.

3. Turn power on. Allow unit to run for an hour. Remove any cubes that may have been ejected during this period. Turn off power and prop door open to allow the inside to defrost. After it has defrosted, wipe it dry and leave door open using door prop.

RECOMMISSIONING

Connect water supply lines, turn on water, check for leaks, then restore power to the unit. After initial cool down of 45-60 minutes, the unit will cycle approximately every 40 minutes.

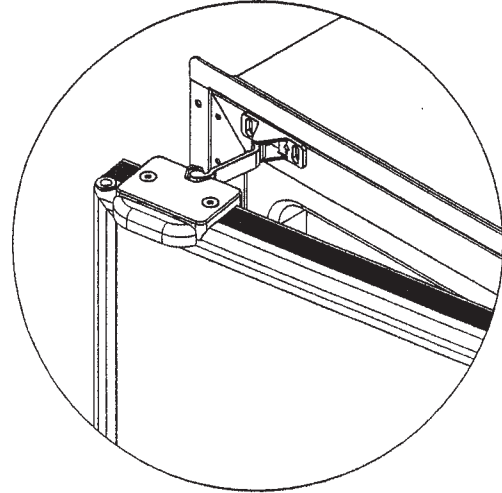

START-UP

Turn on water, check for leaks and then turn on power. Turn on switch (located just below Icer-ette door). Fan and compressor will normally turn on immediately, resulting in air circulation through the grille and a faint hum from the compressor. If machine was shut off while in ice harvesting cycle, it will have to complete the cycle before compressor and fan turn on (approximately 5 minutes). Interior temperature will drop below freezing. First harvest of ice should occur within 60 minutes of start-up. After lines are purged of air, normal harvesting and refilling occur every 40 minutes or less, under normal conditions.

MOUNTING

Required Cabinet Opening:

Model 84: 14 3/8" W x 18 1/2"H

Model 85: 14 3/8" W x 24 5/8"H

WARNING: If rubber feet are removed from the bottom of 85 series units, the mounting screws must be reinstalled into the bottom of the cabinet to avoid damage to components mounted to the base pan.

If unit is to be built-in, 3/4" (2cm) or more must be allowed behind the unit for water line and plug clearance for proper operation. Built-in units are designed for zero clearance at the top and each side of the unit. Fan-forced condenser cooling is used. This requires air circulation through lower section of unit (see Fig. #1). If Icer-ette is to be installed behind closed doors, contact Raritan Technical Support.

CAUTION: Any restriction of airflow or ventilation will disrupt normal operation of the unit, resulting in damage to components and voids warranty.

Unit must sit on a secure level surface. Mounting flange must NOT be used to support the unit's weight.

When installing the unit it should be noted that some servicing requires access to the rear of the unit and that *the unit must be readily removable* should servicing be necessary.

When mounting unit within cabinetry, make sure that the door has the desired range of motion. All doors are hinged on the right (facing the unit) but may be reversed in the field.

PLUMBING

A minimum of 22 P.S.I. (152kPa) is required for proper operation of the water valve (see #26, page 4). When plumbing Icer-ette, 18" (45cm) of water line extends from the back with a 1/4" plastic female compression fitting. Drains are not required; just a water supply.

WIRING

WARNING: HAZARD OF ELECTRIC SHOCK - Never use extension cords or plug adapters to power unit. Never remove the ground prong from the plug.

Power Requirements: 120 volts 60 HZ AC (alternating current); a three-wire cord with grounded plug is supplied, **OR:** 240 volts 50 HZ AC (alternating current), supplied with Euro-plug.

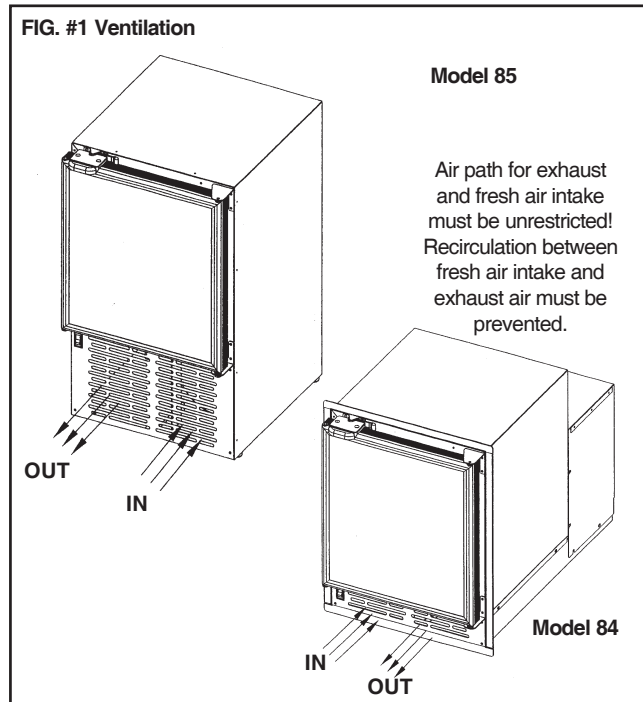

BOTTOM FLANGE INSTALLATION MODEL 85/84B

1. Loosen top two grille screws
2. Remove bottom two grille screws
3. Place bottom trim flange between grille and cabinet.
4. Align holes and install bottom grille screws

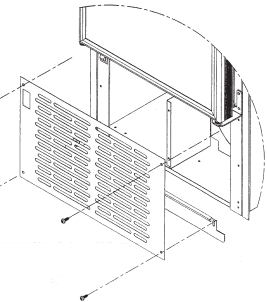

MODEL 85E

Once unit is installed in cabinet

1. Attach trim spacer to bottom flange
2. Slide bottom flange in place.
3. Secure with 2 screws.

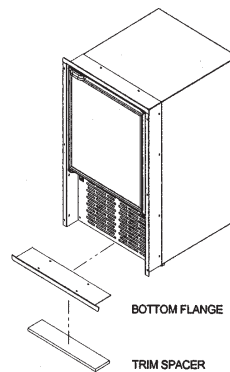

FIG. 1

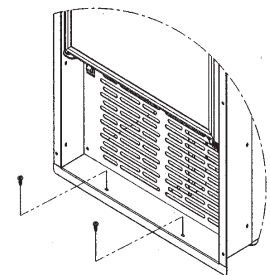
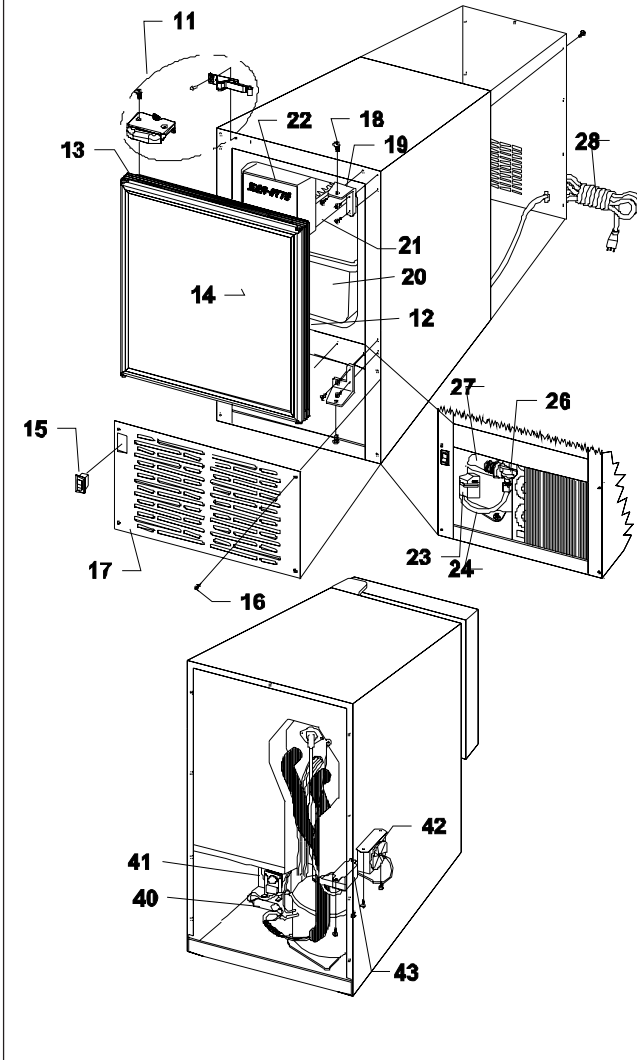

FIG. 2

EXPLODED VIEW

Exploded View of Model 85 Icer-ette



Exploded View of Model 84 Icer-ette

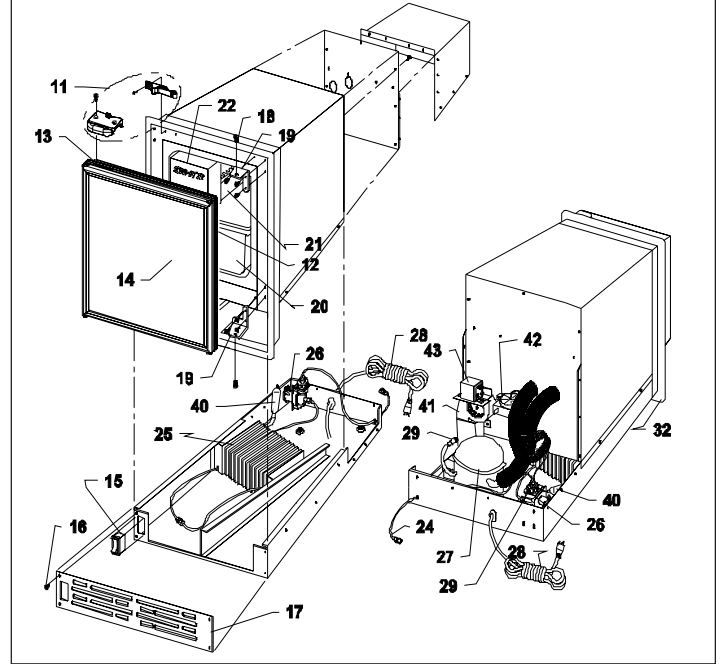

Exploded view of Item #21

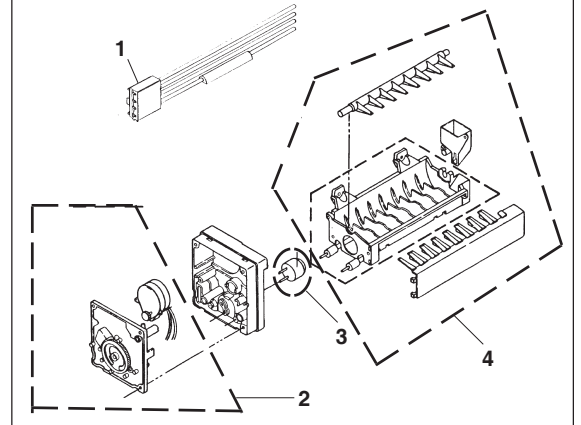

Wiring Diagram Raritan Icer-ette Series 84 and 85

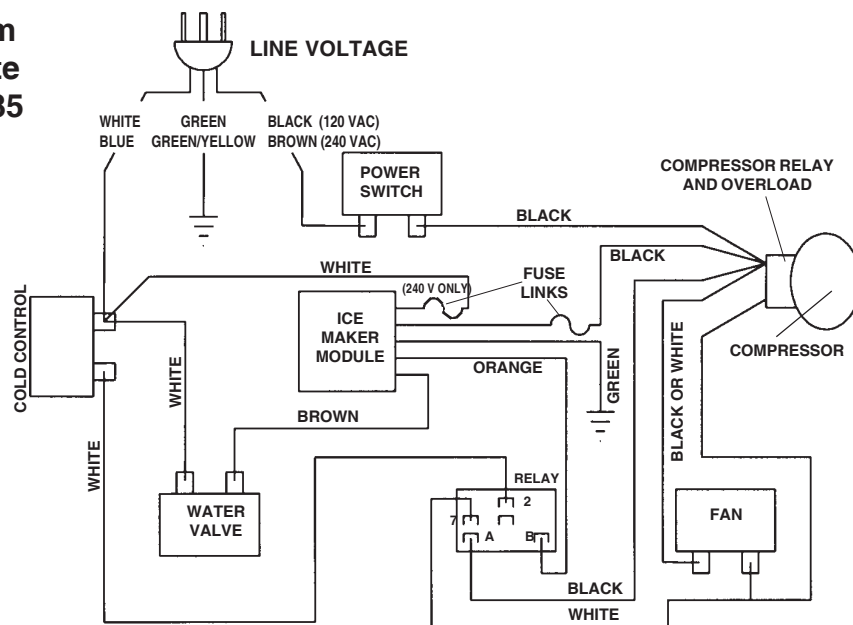

PARTS LIST

Item	Description	Model 84	Model 84 220V		Model 85	Model 85 240V
1	Wiring Harness	I44	I44220		I44	I44220
2	Module Assy. (628366)	I34M-1	I34M220		I34M-1	I34M220
3	Thermostat	I34T	I34T		I34T	I34T
4	Icemaker Mold w/thermostat	I34MH	I34MH220		I34MH	I34MH220
11	Handle Latch Assy.	IM135	IM135		IM135	IM135
12	Door Gasket	IM89	IM89		IM89	IM89
13	Nylon Snap Bushing - Black Nylon Snap Bushing - White	I2101 I21	I2101 I21		I2101 I21	I2101 I21
14	S/S Door Assy. White laminate Door Assy. Black Laminate Door Assy. Neutral White Laminate Door Assy.	IM215W IM216W IM217W IM218W	IM215W IM216W IM217W IM218W		IM215W IM216W IM217W IM218W	IM215W IM216W IM217W IM218W
15	On-Off Rocker switch	I37S	I37S		I37S	I37S
16	8-32 x 1/2 hex head type F 18-8 s/s screws	I73	I73		I73	I73
17	Grille	IM9S01	IM9S01		IM901	IM901
18	Top screw 1/4-28 x 1/2 Bottom screw 1/4-28 x 5/8 hex head	F181 CH51	F181 CH51		F181 CH51	F181 CH51
19	Hinge Set Top & Bottom	IM13W	IM13W		IM13W	IM13W
20	Ice Bucket	I90	I90		I90	I90
21	Ice Maker	I34W	I34220W		I34W	I34220W
22	Ice Maker Front Cover	I34A	I34A		I34A	I34A
23	Relay w/overload protector	I1806-1	I1806-2		I1806-1	I1806-2
24	Water line tubing	I93SW	I93SW		I93	I93
26	Water Valve	I34B	I34B220		I34B	I34B220
27	Compressor (includes #40)	I1800A-1W	I1800A-2W		I1800A-1W	I1800A-2W
28	Power Cord	I41	I41220		I41	I41220
29	Service valve w/tube	I101	I101		I101	I101
40	Drier	I30A01	I30A01		I30A01	I30A01
41	Motor and/or Blower Assy.	I28	I28220		I25	I25220
42	Control	I33A	I33A		I33A	I33A
43	Relay	I52	I52220		I52	I52220

BI Flange Part numbers

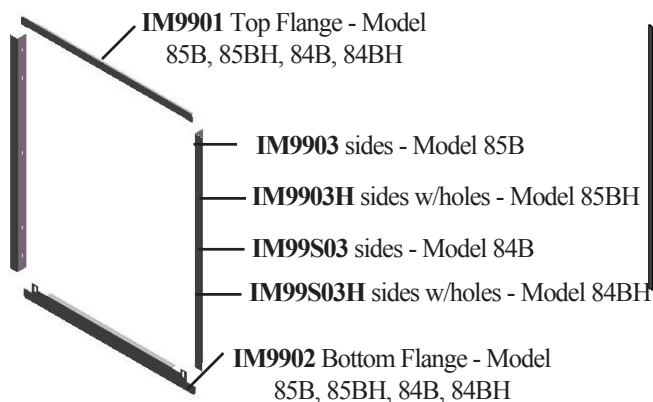

Flush Mount Flange Part numbers

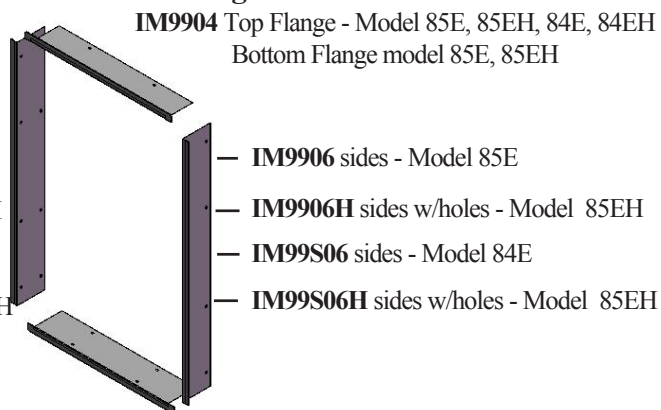

TROUBLESHOOTING

BE SURE TO READ THE FOLLOWING PARAGRAPH BEFORE ATTEMPTING ANY TROUBLESHOOTING OR REPAIR OF ICER-ETTE UNITS.

WARNING: *It is recommended that only a qualified refrigeration technician perform service on Icer-ettes. Because of high voltage, high pressure refrigeration, and presence of water in the unit, a person who is not technically qualified may be subject to electric shock hazard. If the Icer-ette is wired to a junction box or otherwise direct to the AC power supply, the appropriate circuit breaker must be turned off to cut the power to the machine. **TURNING THE ON-OFF SWITCH TO THE "OFF" POSITION DOES NOT DISCONNECT THE UNIT FROM THE POWER SOURCE AND THE DANGER OF ELECTRIC SHOCK WILL REMAIN.***

This Troubleshooting Section is to be used only as a guideline to assist in determining any problem. Raritan does not guarantee that the recommendations or corrections listed below will correct the problem.

PROBLEM	POSSIBLE CAUSE	CORRECTION
1. Compressor and fan not running.	1A. No AC power - check breaker. 1B. AC power switch. 1C. Compressor Relay. 1D. Module. 1E. Cold control.	1A. Turn on breaker to restore power. 1B. Check for loose connections. Replace switch if needed. 1C. Replace Compressor Relay. 1D. Replace icemaker module.* 1E. Replace cold control.*
2. Icer-ette will not get cold enough to freeze cubes in the mold.	2A. Compressor. 2B. Refrigerant leak in system. 2C. Fan motor. 2D. Dust clogged in condenser. 2E. Jammed fan. 2F. Refer to 1 above. 2G. Module	2A. Return to Raritan for compressor replacement. 2B. Contact Raritan Technical Support. 2C. Replace fan motor.* 2D. Clean Condenser (see maintenance section). 2E. Straighten fan brackets. 2F. Refer to 1A, B and C. 2G. Replace icemaker module.*
3. Icer-ette freezes but water does not come into mold; no ice production.	3A. Nonfunctioning water valve assembly. 3B. Mold heater assembly. 3C. Water supply turned off. 3D. Icemaker module. 3E. Cold control. 3F. Bad wiring harness plug contacts.	3A. Clean or replace solenoid valve assembly. 3B. Contact Raritan Technical Support. 3C. Provide pressurized water. 3D. Replace icemaker module. 3E. Replace cold control. 3F. Contact Raritan Technical Support.*
4. Icer-ette will freeze cubes but will not eject them.	4A. Ice mold thermostat. 4B. Icemaker module. 4C. Ejector relay. 4D. Mold and heater assembly. 4E. Bad wiring harness plug contacts.	4A. Replace ice mold thermostat.* 4B. Replace icemaker module.* 4C. Replace ejector relay. 4D. Replace icemaker module.* 4E. Contact Raritan Technical Support.*
5. Icer-ette stops in mid-ejection cycle; compressor will not come back on.	5A. Limit switch in wire harness. 5B. Icemaker module. 5C. Power supply. 5D. Mold and heater assembly. 5E. Bad wiring harness plug contacts.	5A. Contact Raritan Technical Support.* 5B. Replace icemaker module.* 5C. Check connections. 5D. Replace icemaker module. 5E. Contact Raritan Technical Support.*
6. Icer-ette makes and ejects cubes but at a very slow rate.	6A. Ice mold thermostat. 6B. Fan motor. 6C. Ventilation poor. 6D. Dust clogged in condenser. 6E. Too much water in mold. 6F. Ejector relay.	6A. Replace ice mold thermostat.* 6B. Replace fan motor.* 6C. Check installation section. 6D. Clean condenser (see maintenance section). 6E. Contact Raritan Technical Support. 6F. Replace ejector relay.
7. Icer-ette frosts up inside and has to be defrosted often.	7A. Broken door gasket. 7B. Door left open.	7A. Replace door gasket. 7B. Defrost as needed.
8. Excessive accumulation of ice; water overflows the ice mold and runs into storage bucket; solid block of ice.	8A. Solenoid valve assembly. 8B. Icemaker module. 8C. Filler tube alignment. 8D. Icemold thermostat.	8A. Replace solenoid valve assembly. 8B. Replace icemaker module.* 8C. Adjust to prevent splash over. 8D. Replace icemold thermostat.*

* See visual aid reference at www.raritaneng.com/tech support/repair shop

NOTE: Model 84 Icemakers must have back enclosure #30 reinstalled before operating or testing unit. Unit will not operate or test satisfactorily without enclosure in place.

SPECIFICATIONS

SPECIFICATIONS:

Ice Production: up to 22 lbs. (10kg) per day

Water Supply: Minimum 22 psi (152kPa)
Maximum 125 psi (863kPa)

Ice Storage Capacity: up to 11 lbs. (5kg)

Max. AMP Draw: 120 Volt - 2.5; 240 Volt - 1.3

Refrigerant Charge: 2.4 oz. (68 grams) R-134A

Model 84B:

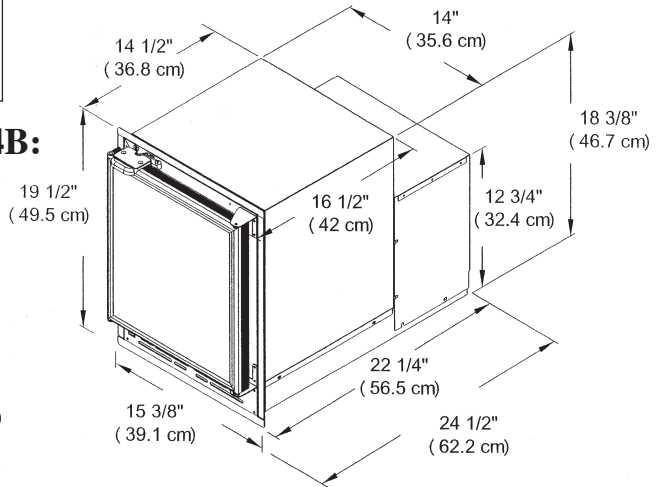

Flush Mount Model 84E:

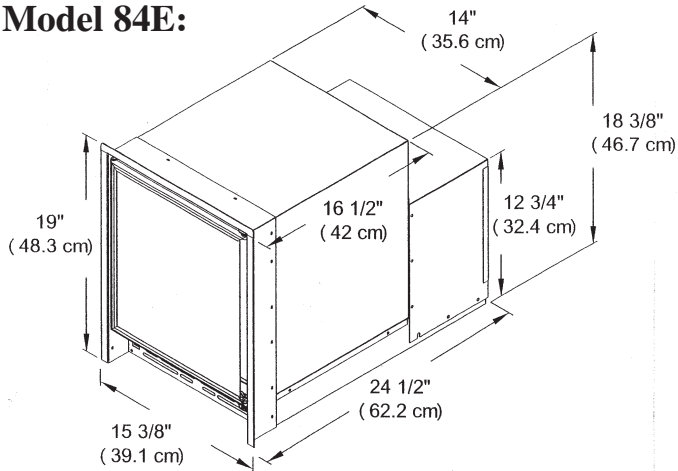

Flush Mount Model 85E:

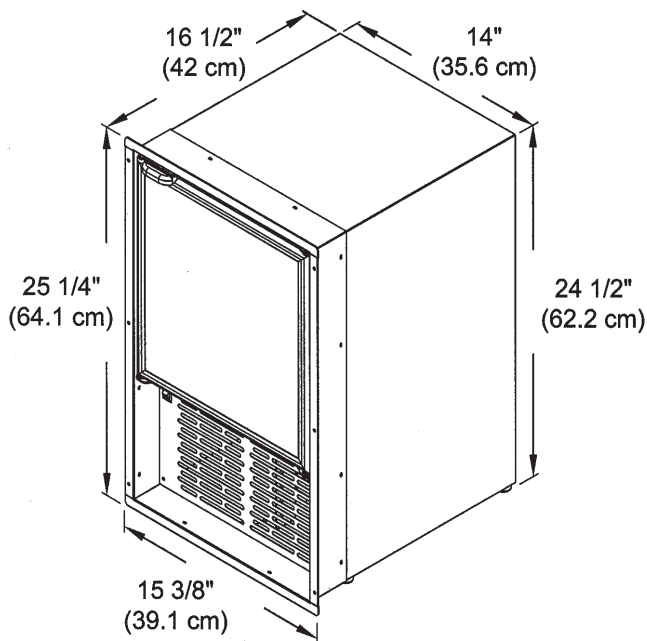

Model 85B:

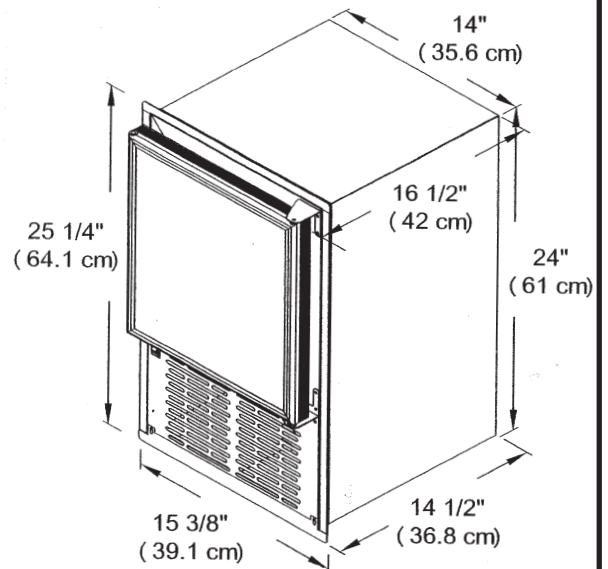

SAVE THESE INSTRUCTIONS

Should a problem arise, please feel free to contact Raritan Technical Support at either the Millville, NJ or Fort Lauderdale, FL office.

LIMITED WARRANTY

Raritan Engineering Company warrants to the original purchaser that this product is free of defects in materials or workmanship for a period of one year from the product's date of purchase. Should this product prove defective by reason of improper workmanship and/or materials within the warranty period, Raritan shall, at its sole option, repair or replace the product.

1. TO OBTAIN WARRANTY SERVICE, Consumer must deliver the product prepaid, together with a detailed description of the problem, to Raritan at 530 Orange St., Millville, N.J. 08332, or 3101 SW 2nd Ave. Ft. Lauderdale, FL 33315. When requesting warranty service, purchaser must present a sales slip or other document which establishes proof of purchase. **THE RETURN OF THE OWNER REGISTRATION CARD IS NOT A CONDITION PRECEDENT OF WARRANTY COVERAGE.** However, please complete and return the owner Registration Card so that Raritan can contact you should a question of safety arise which could affect you.
2. **THIS WARRANTY DOES NOT COVER** defects caused by modifications, alterations, repairs or service of this product by anyone other than Raritan; defects in materials or workmanship supplied by others in the process of installation of this product; defects caused by installation of this product other than in accordance with the manufacturer's recommended installation instructions or standard industry procedures; physical abuse to, or misuse of, this product. This warranty also does not cover damages to equipment caused by fire, flood, external water, excessive corrosion or Act of God.
3. **ANY EXPRESS WARRANTY NOT PROVIDED HEREIN, AND ANY REMEDY FOR BREACH OF CONTRACT WHICH BUT FOR THIS PROVISION MIGHT ARISE BY IMPLICATION OR OPERATION OF LAW, IS HEREBY EXCLUDED AND DISCLAIMED. ALL IMPLIED WARRANTIES SUCH AS THOSE OF MERCHANTABILITY AND OF FITNESS FOR A PARTICULAR PURPOSE, IF APPLICABLE, AS WELL AS ANY IMPLIED WARRANTIES WHICH MIGHT ARISE BY IMPLICATION OF LAW, ARE EXPRESSLY LIMITED TO A TERM OF ONE YEAR. SOME STATES DO NOT ALLOW LIMITATIONS ON HOW LONG A LIMITED WARRANTY LASTS, SO THE ABOVE LIMITATION MAY NOT APPLY TO YOU.**
4. **UNDER NO CIRCUMSTANCES SHALL RARITAN BE LIABLE TO PURCHASER OR ANY OTHER PERSONS FOR ANY SPECIAL OR CONSEQUENTIAL DAMAGES, WHETHER ARISING OUT OF BREACH OF WARRANTY, BREACH OF CONTRACT, OR OTHERWISE. SOME STATES DO NOT ALLOW THE EXCLUSION OR LIMITATION OF INCIDENTAL OR CONSEQUENTIAL DAMAGES, SO THE ABOVE LIMITATION OR EXCLUSION MAY NOT APPLY TO YOU.**
5. No other person or entity is authorized to make any express warranty, promise or affirmation of fact or to assume any other liability on behalf of Raritan in connection with its products except as specifically set forth in this warranty.
6. This warranty gives you specific legal rights, and you may also have other rights which vary from state to state.



530 Orange Street, Millville, NJ 08332 USA
Telephone: 856-825-4900 FAX: 856-825-4409
www.raritaneng.com
Southern Office and Plant:
3101 SW Second Avenue, Fort Lauderdale, FL 33315 USA
Telephone: 954-525-0378 FAX: 954-764-4370