

KNOCK OUT ODORS KIT

Installation Instructions

WARNING: *Raritan Engineering Company Inc. recommends that a qualified person or electrician install this product. Equipment damage, injury to personnel or death could result from improper installation. Raritan Engineering Company Inc. accepts no responsibility or liability for damage to equipment, or injury or death to personnel that may result from improper installation or operation of this product.*



WARNING: HAZARD OF FLOODING- Always shut off seacocks before leaving boat unattended. Double clamp all hose fittings below waterline, check hose clamps frequently for integrity. Refer to toilet instruction manual for below water line installation of toilet.

Knock Out Odors Kit includes:

3 quart tank, metering valve with check valve, fittings, 1/4" hose, 22 oz bottle of Cleans Potties (C.P.) and a 22 oz bottle of Kills Odor (K.O.).

OPERATION:

Dispenser tank adds a preset amount of diluted C.P. with every flush. Bacteria introduced by C.P. breaks down organic matters in the inlet hose and bowl rim that cause sulfide generating bacteria (rotten egg smell). This bioactive formula stops the generation of odor without the use of chemicals such as chlorine or formaldehydes.

Adding K.O. through the toilet after each pump out eliminates odors from the holding tank and discharge hose.

Sani/Flex® odor shield sanitation hose (SFH) is recommended for preventing any odors permeating through hose.

Installation:

1. Locate deodorizing tank as per fig 1,2, 3 or 4, secure tank with screws.

Warning: Refer to toilet instruction manual to determine required vented loop height.

2. Install T check valve in the suction side of pump, secure hose with clamps.
3. Connect 1/4" hose.
4. Fill up the tank with clean water.
5. Close metering valve completely and open 1/4 turn.
6. Flush toilet and adjust metering valve until you get approximately 3 flushes per line.
7. Refill tank and add 4.5 ozs of C.P. per tank.
8. Flush toilet and check for leaks.

FIG 1

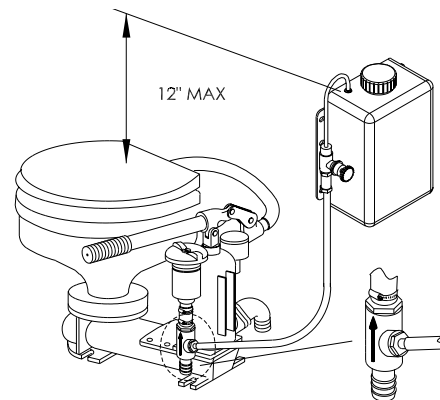

Manual toilet above water line - Tank MUST NOT be mounted higher than 12" above bowl

FIG 2

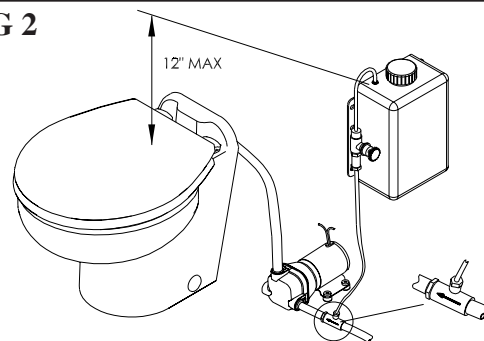

Electric Toilet above water line - Tank MUST NOT be mounted higher than 12" above bowl

Refill:

- Add 4.5 ozs of C.P. directly into dispenser tank.
- After every pump out, flush 4 ozs of K.O. per 25 gallons of holding tank capacity through the toilet (see bottle label for complete instructions).

Note: K.O. works best when holding tank has adequate ventilation.

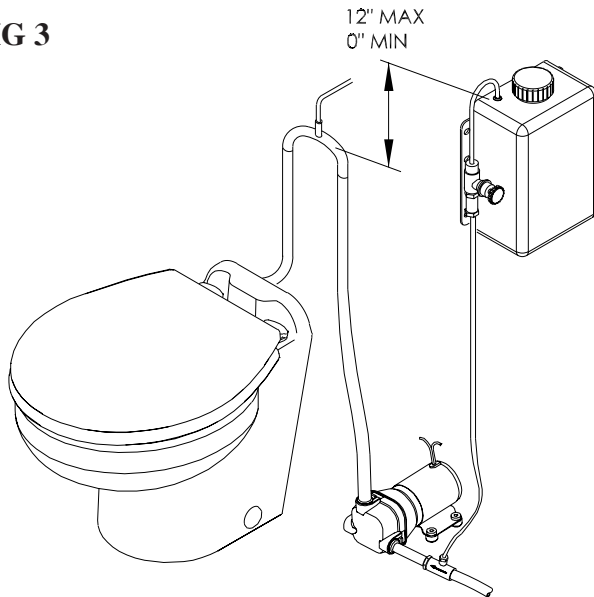
FIG 3

**Electric toilet below water line - Top of tank
MUST not be below top of vented loop**

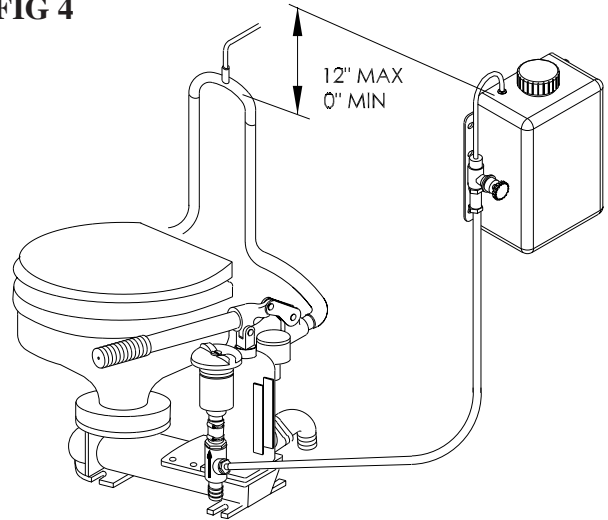
FIG 4

**Manual toilet below water line - Top of tank
MUST not be below top of vented loop**

Parts List:

	Part #	Description
1	39002W	Tank 3 quart
2	PLVF0-25	Metering valve
3	39006	Check valve 1/4"
4	39007	T check valve 3/4"
5	31-305	1/4" hose

Reorder Part # for C.P. bottle : 1PCP22

Reorder part # for K.O. bottle : 1PKO22

1 1/2" Sani/Flex® hose: SFH

1" Sani/Flex® hose: SFH1

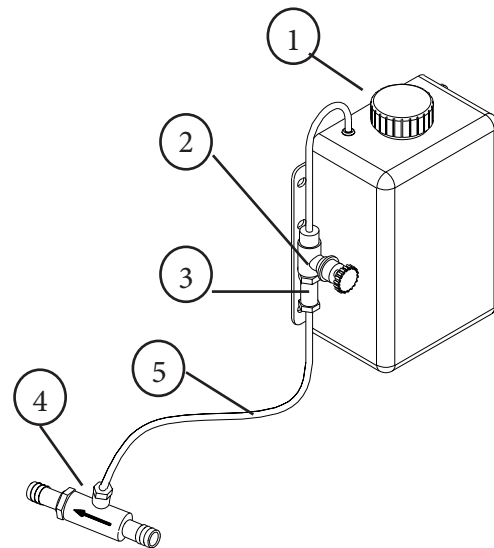
FIG 5**Parts list**

530 Orange Street, Millville, NJ 08332 USA
Telephone : 856-825-4900 FAX : 856-825-4409

www.raritaneng.com

Southern Office and Plant :

3101 SW Second Avenue, Fort Lauderdale, FL 33315 USA

Telephone : 954-525-0378 FAX : 954-764-4370