



*The Most Dependable Name on the Water*



## ***electro scan***

U.S. Coast Guard approved  
Type I Marine Sanitation Device

**Electro Scan consistently controls the electrodes to reduce power consumption by up to 36%. New LCD display provides detailed user information.**

### **Control system designed to maximize performance and operation**

- Electrode amps are controlled by the system for optimum performance and reduced current draw
- An LCD display provides system status and diagnostic information
- Solid State Overload protection eliminates the fuses and relays, once tripped a simple reset will allow the unit to function again
- Historical operational data is stored on a board that is easily returned to the factory or dealer for download to a PC

### **Environmentally Friendly**

- Generates its own natural disinfectant from salt water
- Coated electrodes use salt water to kill bacteria and viruses without the addition of harmful chemicals
- Discharges with treatment levels that are safe for environmentally sensitive areas

### **Simple to Use - For Powerboats and Sailboats**

- One-step activation with toilet switch or system status panel automatically activates both toilet and treatment system
- Eliminates the need for bulky holding tanks by treating each flush
- Available for 12, 24 and 32V DC

### **Options**

- (1) Toilet sensor starts treatment unit when manual toilet is flushed,
- (2) Dual control for use with two toilets
- (3) Salt feed system. Required when using fresh or brackish water, three models to choose from.

*Raritan products are chosen by powerboat, sailboat, houseboat, and RV owners and manufacturers the world over for their dependability, environmental responsibility, simplicity of installation, operation, and maintenance. The product line includes house-hold style toilets, marine toilets, marine sanitation devices and systems, cleaning products, icemakers, water heaters, and rudder angle indicators.*

*To view our complete line as well as obtain installation and servicing guides: visit [www.raritaneng.com](http://www.raritaneng.com)*

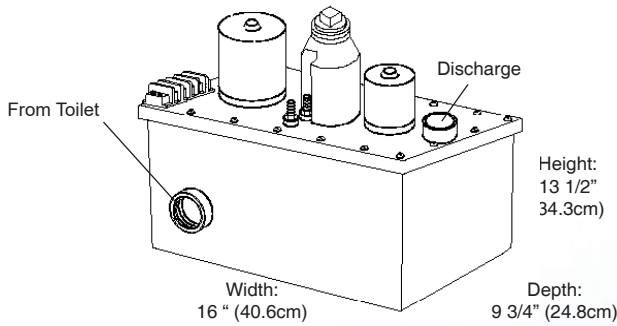

Approximate Shipping Weight: 25 lbs (9 kg)

The electro scan utilizes electrodes which temporarily convert salt water into a powerful bactericide. The treated waste water then safely and conveniently reverts back to its original state of salt and water. No unnatural or harmful chemicals enter our environment.

The design of the treatment tank optimizes the thoroughness of treatment by forcing the bactericide and bacteria into direct contact, effectively killing viruses and bacteria.

The electro scan can be installed with one or two marine toilets to form a complete sanitation system. Pressing the "START STOP" pad activates the treatment cycle. The toilet(s) can be interfaced to provide one touch toilet flushing and treatment activation. The LCD Display lists current system status and also stores historical data for a variety of diagnostics.

### Sample Installation

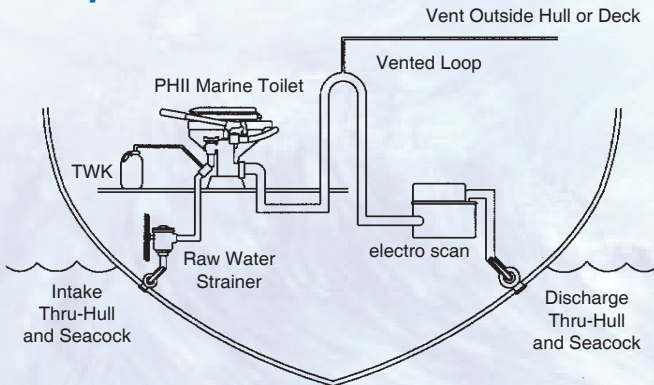

Electro Scan with Vented Loop (Above Waterline)

### Operation

The flushing action of the toilet discharges waste into the first chamber of the Treatment Tank. Here the waste is macerated and receives its first treatment. Specially coated electrode plates create an electrical field and convert salt water into hypochlorous acid, a powerful bactericide. Once the treatment solution reacts with bacteria and waste, it reverts back to salt and water.

The next time the toilet is flushed and new untreated discharge water enters the first chamber, some of the treated discharge enters the second chamber. While the new waste is being treated in the first chamber, the contents of the second chamber are stirred and treated again. Each successive flush moves the previous toilet discharge through the electro scan and eventually overboard or into a holding tank. When the discharge enters the marine environment, virtually all pathogens have been eliminated.

### Sample LCD Text messages:

READY TO FLUSH	***TREATMENT*** VOLTAGE= 100%
****WARNING**** VOLTAGE LOW	****WARNING**** AMP = 10
****WARNING**** AMPS < 14	****WARNING*** VOLTAGE < 87%
**PRETREATMENT** VOLTAGE= 100%	***TREATMENT*** AMPS = 15

For more information contact:

Raritan Engineering Company Inc.  
530 Orange Street  
Millville, NJ 08332, USA  
Telephone: 856-825-4900  
Toll Free: 1-800-352-5630  
Fax: 856-825-4409  
e-mail: info@raritaneng.com

Florida Telephone: 954-525-0378



[raritaneng.com](http://raritaneng.com)