

TANK MONITOR

MODEL # 1510012 (12V DC) - 1510024 (24V DC) - 1510032 (32V DC)

OPERATION AND INSTALLATION INSTRUCTIONS

WARNING: *Raritan Engineering Company, Inc. recommends that a qualified person install this product. Equipment damage, injury to personnel or death could result from improper installation. Raritan Engineering Company, Inc. accepts no responsibility or liability for damage to equipment, or injury or death to personnel, that may result from improper installation or operation of this product.*

NOT FOR USE ON FUEL TANKS.

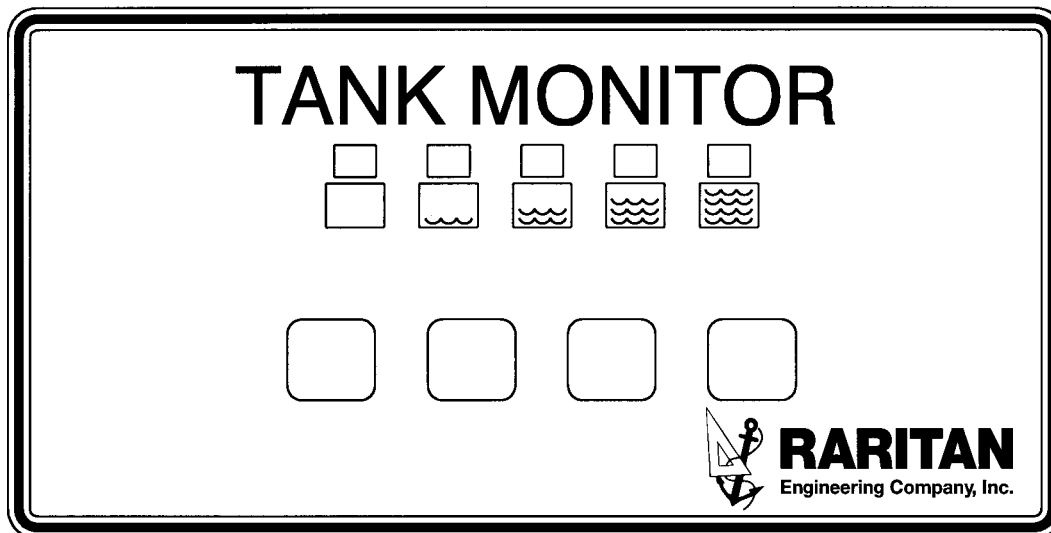

This tank monitor system is easy to use and monitors up to four tanks from one convenient location. The smooth surface indicator panel clearly displays how full the tank is by simply pressing a touch pad.

NOTE: This product is designed for plastic, fiberglass or fibreglassed wood holding tanks.

NOTE: Product meets all applicable European Council Directives for recreational crafts and is marked CE. Declaration of Conformity available upon request.



1-800-352-5630
www.raritaneng.com

OPERATION

Press touch pad of tank to be checked.

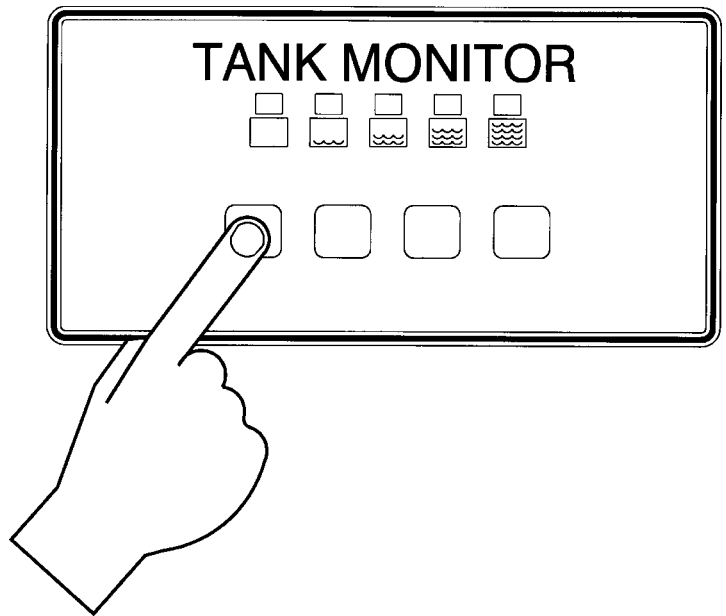

The lights on the indicator panel show the fluid level of the tank selected when the touch pad is pressed.

This figure shows the fluid level at $\frac{1}{4}$ full. If the tank is full all five lights will light up.

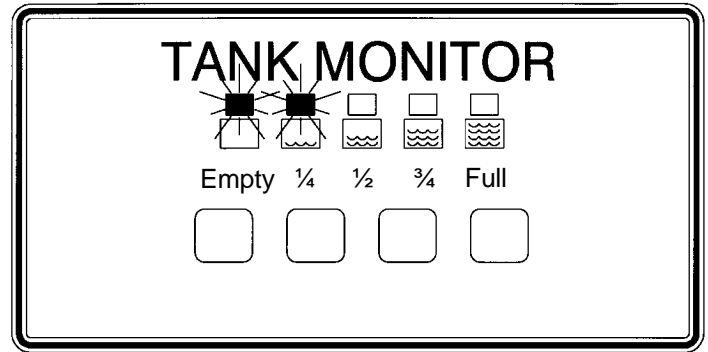

The international symbol labels shown below should be placed on the appropriate touch pad on the indicator panel to identify the tank's contents. Two of each of these labels is provided.

Waste Water

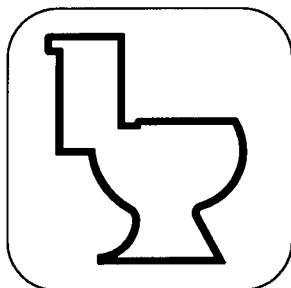

Gray Water

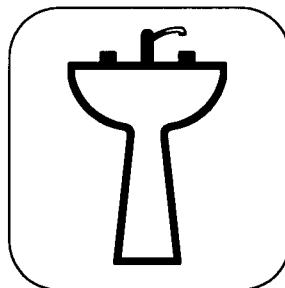

Fresh Water



Parts Included:

- Indicator Panel
- Tank Sensor Modules (2)
- Fuse-holder with 3 amp fuse
- Splice Connectors (12)
- Symbol Labels: (two [2] each; Waste, Gray and Fresh)
- Roll Aluminum Foil Tape (10 foot [3m])
- Screws to Mount Indicator Panel to Wall (4)
- Calibration Tool

Tools Required:

- Flat Blade Screw Driver
- Saw or Router
- Drill with 5/64" (2mm) drill bit
- Wire Cutters
- Wire Terminal Crimpers(for 18 AWG)(1.0mm²)
- Scissors or Razor Knife
- Tape Measure
- Small Level

Additional Materials Required :

- Stranded 18 AWG (1.0 mm²) (sufficient length to run from panel to all tanks and power source).
- Wire Terminals to connect Tank Monitor to the power source.
- Rubbing Alcohol (Isopropyl)

IMPORTANT: Read all instructions before proceeding with installation.

MOUNTING THE INDICATOR PANEL

1. Choose a location that is easily seen, accessible and not exposed to the weather.

NOTE: Locate in an area where wires can be routed to the Indicator Panel. Minimum Depth 1 1/4"(3.5cm).

2. Using the template (Fig. #1), mark areas on wall to be cut out and drilled.
3. Cut opening and drill four (4) 5/64" (2mm) holes.
4. Puncture overlay at the center of each mounting hole (4) using an awl or a 5/64" (2 mm) drill bit.

NOTE: Holes are not provided in the Indicator Panel's face to allow for other mounting options.

5. Mount the Indicator Panel using the four (4) screws provided.

NOTE: Do not mount Indicator Panel to the wall until wiring and calibrations are completed.

Fig. # 1 Mounting Template for Tank Monitor Indicator Panel

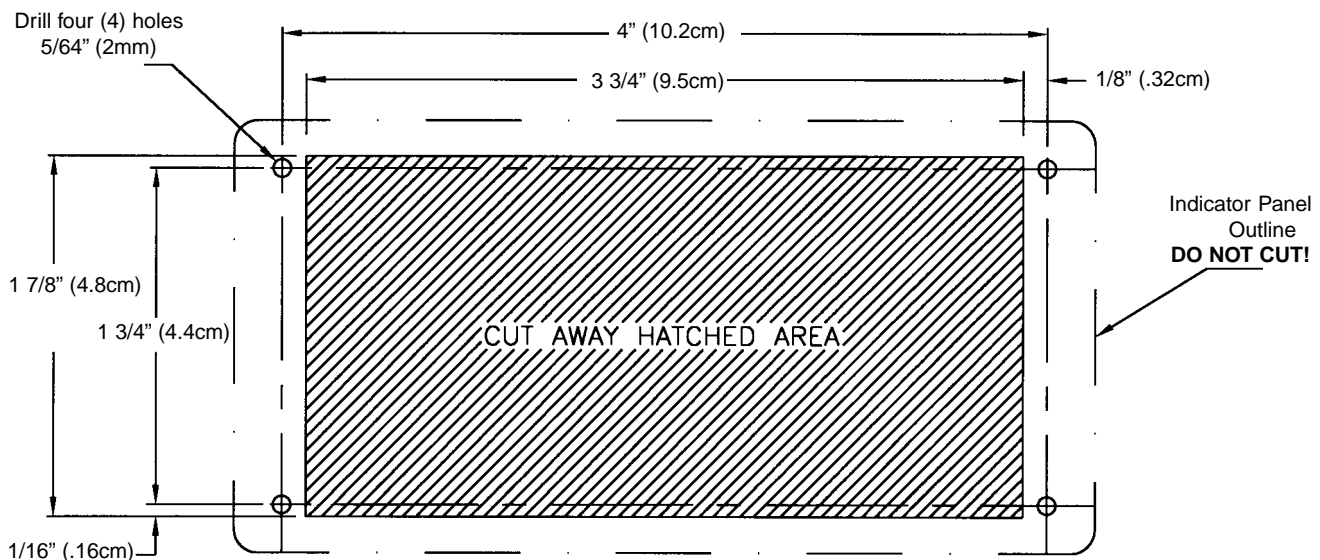

Mounting the Tank Sensor Modules

NOTE: This product is designed for plastic, fiberglass or fiberglassed wood tanks.

The aluminum foil tape strips must be at least 1" (2.5cm) from any large metal objects, such as, framework, siding, stored items, etc. and located on the side of the tank.

1. Measure the height of the tank where the Tank Sensor Modules will be mounted. See **Fig. #2**.
2. Cut *two* strips of aluminum foil tape (supplied) 1" (2.5cm) less than the height of the holding tank.
3. Calculate the area of *each* aluminum foil tape strip. Multiply the length of the tape by the width.

The aluminum foil tape supplied is 2" (5.1cm) wide.

Each aluminum foil tape strip should be between 15 and 40 square inches (97 and 258 square centimeters).

If the area is between 15 and 40 square inches (97 and 258cm square), go to step 4.

If the area is less than 15 square inches (97cm square), the width of each aluminum foil tape strip must be increased. Cut two more lengths of

Fig. #2

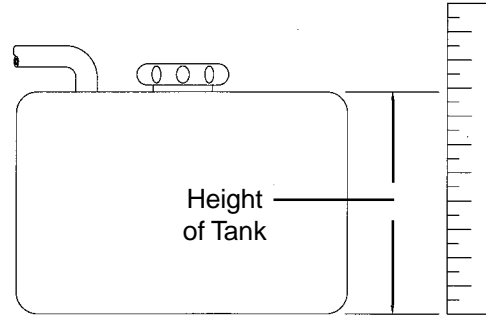

aluminum foil tape the same length as the first two. How to install them will be explained later.

*If the area is more than 40 square inches (258cm square), decrease the **width** of the original aluminum foil tape strip by trimming.*

IMPORTANT: Do not adjust the length (height) of aluminum foil tape strip when increasing or decreasing the area of the original aluminum foil tape strip.

EXAMPLE: Tank Height = 11"

**11" (27.9cm) minus 1" (2.5cm) = 10" (25.4cm)
(Length of aluminum foil tape strip)**

**10" (25.4cm) multiplied by 2" (5.1cm) = 20
square inches (129cm square)**

Template on Other Side

- Clean area thoroughly with isopropyl alcohol.
NOTE: For tanks that have a rough surface; smooth surface by sanding carefully before cleaning. A thin coating of contact adhesive may have to be applied.

IMPORTANT: If using contact adhesive, be certain there is adequate ventilation and adhesive will not damage tank.

- Remove paper backing from aluminum foil tape strips.
- Place two aluminum foil tape strips vertically on tank surface, 1/2" (1.27cm) from top and bottom of tank. Aluminum foil tape strips are to be parallel 2" (5cm) to 4" (10cm) apart. See **Fig. #3**.

For aluminum foil tape strips that are less than 15 square inches [97cm square] (from step 3). Divide the minimum area (15 square inches [97cm square]) by the length of the aluminum foil tape strip. This is the minimum width that the installed overlapping aluminum foil tape strips needs to be.

Example: 15" (38cm) divided by 6" (15cm) = 2 1/2" (6.4cm) minimum width of the two overlapping aluminum foil tape strips.

Place the second aluminum foil tape strips overlapping the first aluminum foil tape strips to at least minimum width. See **Fig.# 3A**.

- Remove paper backing from tank sensor module and place between the two aluminum foil tape strips. See **Fig #4**. The tank sensor module may be placed anywhere between the aluminum foil tape strips.
- Remove paper backing from copper pads and place one on each aluminum foil tape strip. See **Fig #4**.

Trim copper pads accordingly if they are wider than the aluminum foil tape strips.

Place copper pads over the exposed seam if two aluminum foil tape strips are overlapped. See **Fig #4A**.

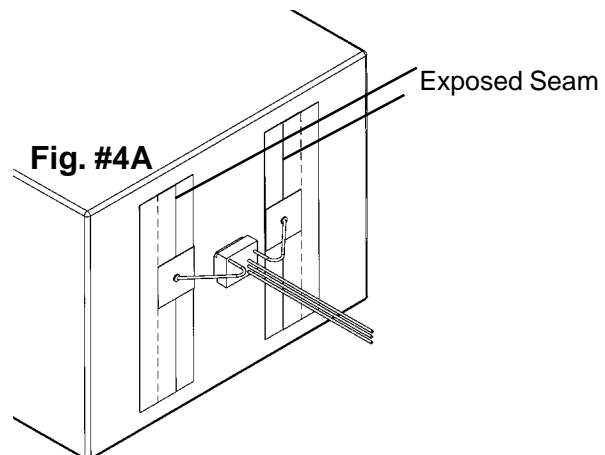
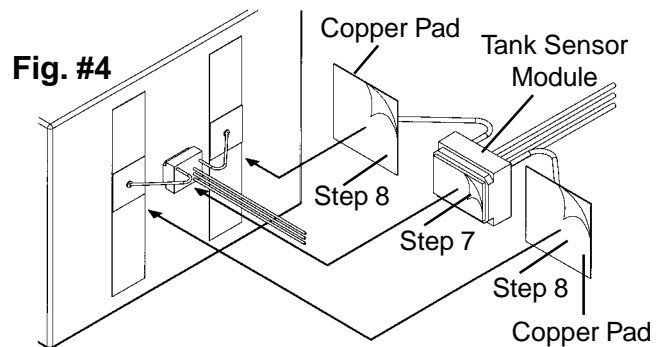
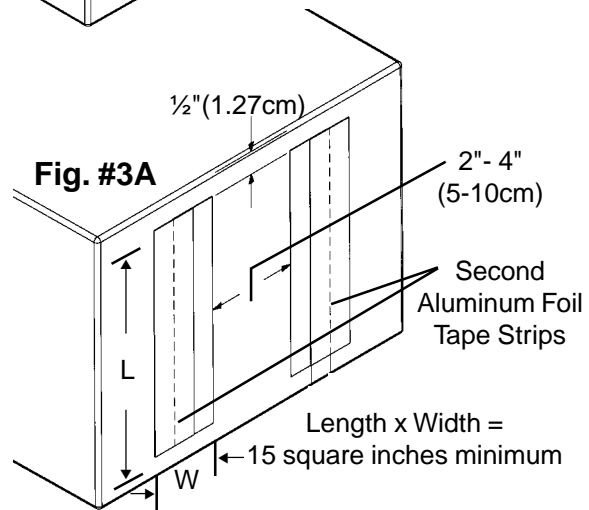
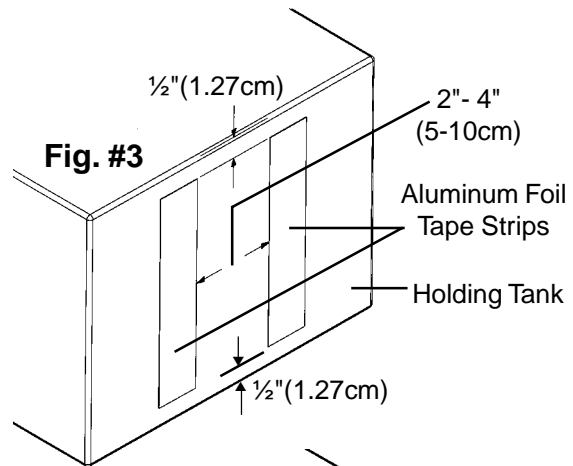

WIRING

WARNING: Hazard of shock and fire. Disconnect power before proceeding.

IMPORTANT: Use only 18 AWG (1.0mm²) stranded wire for connecting Indicator Panel to Tank Sensor Module(s) and DC power supply. Avoid using nails and staples to support wires. Do not route wire near any heat source. Wire to wire connections are to be made by the splice connectors (supplied). Strip all wires ¼" (6.5mm) before crimping on splice connectors.

Follow Fig. #5 for Indicator Panel to Tank Sensor Module(s) wiring information.

1. Connect green wire from the Indicator Panel to green wire of the Tank Sensor Module.
2. Connect orange wire from the Indicator Panel to orange wire of the Tank Sensor Module.
3. Connect *black* wire from Tank Sensor Module to negative (-) side of DC power supply.
4. Connect *black* wire from the Indicator Panel to negative (-) side of DC power supply.
5. Connect *red* wire from the Indicator Panel to positive (+) side of DC power supply.
6. Install the Fuse in the positive (+) line at the power source. Be certain the fuse cover is in place over fuse.
7. Place appropriate symbol label to the Touch Pad (gold square area) on the Indicator Panel.

Calibrating the Indicator Panel

1. Fill all tanks 90% full.
2. Press and hold touch pad #1.
3. Insert calibration tool into the hole in the back of the Indicator Panel that is directly behind the Touch Pad #1 and slowly turn calibration tool clockwise, as viewed from the rear, until some of the lights turn off. See Fig. #6.
4. Slowly turn the same Calibration tool counter-clockwise *just past the point where the full light is flickering* and all lights are on.
5. Repeat steps 2, 3 and 4 for each tank in use. Calibrations should be made to corresponding Touch Pad and adjustment openings.
6. After all calibrations have been completed mount the Indicator Panel in wall opening.

Fig. #5

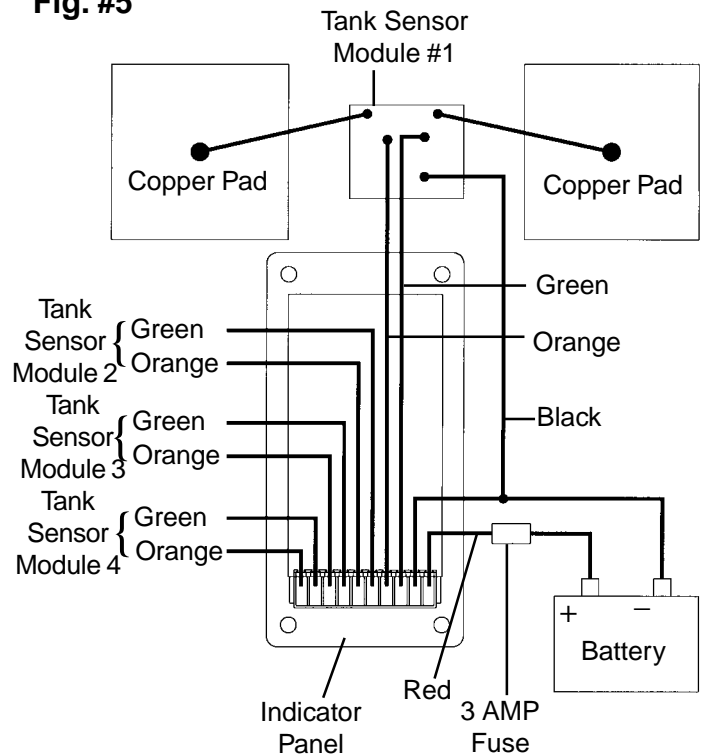
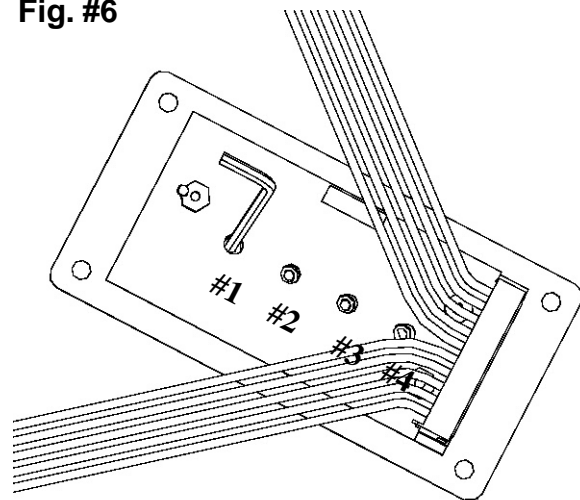

Fig. #6



TROUBLESHOOTING

Contact Raritan Technical Support for additional assistance.

Problem	Possible Cause	Correction
Monitor panel lights indicate tank 1/4" full but tank is really empty.	1. Aluminum foil tape strip extends down too low on tank	1. Trim aluminium foil tape strip 1/2" above tank bottom.
	2. Metal object within one inch of aluminum foil tape strips.	2. Remove metal object or change position of aluminum foil tape strips and module.
	3. Re-calibration needed.	3. Follow steps for calibration on page 6.
Tank Monitor lights not working.	Check voltage at indicator panel, voltage should be same voltage as ship's DC system (12, 24 or 32V DC).	If low voltage check all connections, grounds and the fuse for tightness and integrity.

EXPLODED PARTS VIEW AND PARTS LIST FOR TANK MONITOR

- | | <u>Part #</u> | <u>Description</u> |
|----|---------------|---------------------|
| 1. | 1520012 | Indicator Panel 12V |
| | 1520024 | Indicator Panel 24V |
| | 1520032 | Indicator Panel 32V |
| 2. | 152WH | Wire Harness |

Tank Sensor Module Kit (Part #15101) may be ordered separately for additional tank(s). Parts included:

- | <u>Part #</u> | <u>Description</u> |
|---------------|--------------------|
| 15300 (1) | Tank Sensor Module |
| 15310 (5') | Aluminum Foil Tape |
| C2218-SC (5) | Splice Connectors |

Parts Not Shown

- | <u>Part #</u> | <u>Description</u> |
|---------------|-----------------------|
| EF3 | 3 AMP Fuse |
| EFH01 | Fuse Holder |
| 15111 | Calibrating Tool |
| L314 | Labels |
| 15300 | Tank Sensor Module |
| 15310(10') | Aluminum Foil Tape |
| C2218-SC(12) | Splice Connectors |
| F153(4) | Brass Mounting Screws |

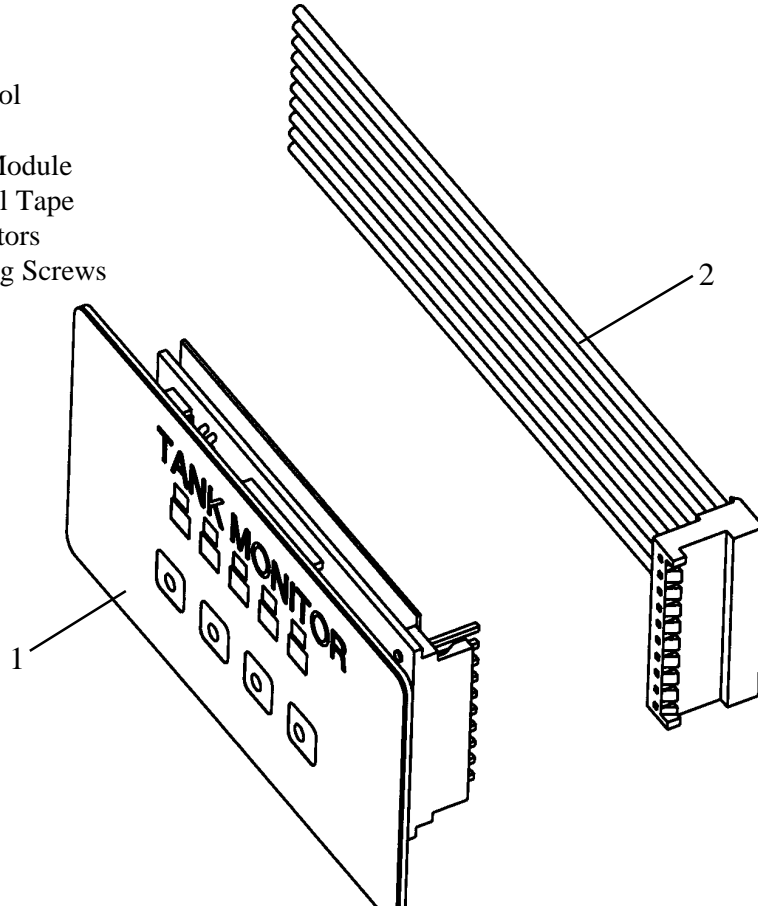

LIMITED WARRANTY

Raritan Engineering Company warrants to the original purchaser that this product is free of defects in materials or workmanship for a period of one year from the product's date of purchase. Should this product prove defective by reason of improper workmanship and/or materials within the warranty period, Raritan shall, at its sole option, repair or replace the product.

1. TO OBTAIN WARRANTY SERVICE, Consumer must deliver the product prepaid, together with a detailed description of the problem, to Raritan at 530 Orange St., Millville, N.J. 08332, or 3101 SW 2nd Ave. Ft. Lauderdale, FL 33315. When requesting warranty service, purchaser must present a sales slip or other document which establishes proof of purchase. **THE RETURN OF THE OWNER REGISTRATION CARD IS NOT A CONDITION PRECEDENT OF WARRANTY COVERAGE.** However, please complete and return the owner Registration Card so that Raritan can contact you should a question of safety arise which could affect you.
2. **THIS WARRANTY DOES NOT COVER** defects caused by modifications, alterations, repairs or service of this product by anyone other than Raritan; defects in materials or workmanship supplied by others in the process of installation of this product; defects caused by installation of this product other than in accordance with the manufacturer's recommended installation instructions or standard industry procedures; physical abuse to, or misuse of, this product. This warranty also does not cover damages to equipment caused by fire, flood, external water, excessive corrosion or Act of God.
3. **ANY EXPRESS WARRANTY NOT PROVIDED HEREIN, AND ANY REMEDY FOR BREACH OF CONTRACT WHICH BUT FOR THIS PROVISION MIGHT ARISE BY IMPLICATION OR OPERATION OF LAW, IS HEREBY EXCLUDED AND DISCLAIMED. ALL IMPLIED WARRANTIES SUCH AS THOSE OF MERCHANTABILITY AND OF FITNESS FOR A PARTICULAR PURPOSE, IF APPLICABLE, AS WELL AS ANY IMPLIED WARRANTIES WHICH MIGHT ARISE BY IMPLICATION OF LAW, ARE EXPRESSLY LIMITED TO A TERM OF ONE YEAR. SOME STATES DO NOT ALLOW LIMITATIONS ON HOW LONG A LIMITED WARRANTY LASTS, SO THE ABOVE LIMITATION MAY NOT APPLY TO YOU.**
4. **UNDER NO CIRCUMSTANCES SHALL RARITAN BE LIABLE TO PURCHASER OR ANY OTHER PERSONS FOR ANY SPECIAL OR CONSEQUENTIAL DAMAGES, WHETHER ARISING OUT OF BREACH OF WARRANTY, BREACH OF CONTRACT, OR OTHERWISE. SOME STATES DO NOT ALLOW THE EXCLUSION OR LIMITATION OF INCIDENTAL OR CONSEQUENTIAL DAMAGES, SO THE ABOVE LIMITATION OR EXCLUSION MAY NOT APPLY TO YOU.**
5. No other person or entity is authorized to make any express warranty, promise or affirmation of fact or to assume any other liability on behalf of Raritan in connection with its products except as specifically set forth in this warranty.
6. This warranty gives you specific legal rights, and you may also have other rights which vary from state to state.



530 Orange Street, P.O. Box 1157, Millville, NJ 08332 USA
Telephone: 856-825-4900 FAX: 856-825-4409
www.raritaneng.com
Southern Office and Plant:
3101 SW Second Avenue, Fort Lauderdale, FL 33315 USA
Telephone: 954-525-0378 FAX: 954-764-4370