





ELECTRIC WATER HEATERS

With or Without Optional Heat Exchanger INSTALLATION and MAINTENANCE INSTRUCTIONS 1700 Series Models

WARNING:  Raritan Engineering Company, Inc. recommends that a qualified person or electrician install and service this product. Equipment damage, injury to personnel or death could result from improper installation. Raritan Engineering Company, Inc. accepts no responsibility or liability for damage to equipment, injury to personnel or death that may result from improper installation or operation of this product.

WARNING:   **Hazard of Shock or Fire** - Always use recommended fuse/circuit breaker and wire size. Always make sure that unit is properly grounded to AC grounding conductor (green). Do not use an extension cord. Contact a qualified electrician to have wiring properly installed.

Hazard of Scalding - Water temperature over 125°F (52°C) can cause severe burns instantly. Supervise children when using hot water. Water heaters equipped with engine heat exchanger can heat water to very high temperature. **Thermostatic mixing valve should be installed before point of use to limit the water temperature to maximum of 125° F (52° C). For more information, see your qualified technician.**

WARNING:  Hydrogen gas can be produced in a hot water system served by this heater that has not been used for a long period of time (generally 2 weeks or more). Hydrogen gas is extremely flammable. To reduce the risk of injury under these conditions, it is recommended that a hot water faucet be opened for several minutes before using any electrical appliance connected to the hot water system. If hydrogen is present, there will probably be an unusual sound such as air escaping through the pipe as the water begins to flow. There should be no smoking or open flame near the faucet when it is initially opened.

DESCRIPTION

Raritan Water Heaters are constructed with high quality components: a glass lined tank, high density non-CFC foam insulation, noncorrosive polymer jacket and an adjustable Thermostat. Models with an internal Heat Exchanger heat water from an external source. Dockside hot water recovery rate is 13 gallons (49.2 liters) per hour. (18 gallons [68.1 liters] per hour for model #17120203 or 17200203 with 4500 watt/ 240V heating element). Ground terminal and replaceable Anode are built in. Temperature and Pressure Valve rated at 75 psi (517 kPa) 210°F (99°C) is included for on-board nominal working system pressure of 50 psi (345 kPa) maximum. If working pressure is 60 psi (414 kPa) then a temperature and pressure valve rated at 100 psi (790 kPa) is available (part WH3A). If operating pressure exceeds 60 psi (414 kPa) then use a pressure reducing valve for entire plumbing on the boat. The water heater is ignition protected as per United States Coast Guard regulation 33 CFR 183.410.

IMPORTANT SAFETY INSTRUCTIONS

1. Read all instructions thoroughly.
2. Install or locate water heater in accordance with the provided installation instructions.
3. Use water heater only for its intended use as described in this manual.
4. Do not operate if wiring is damaged, or if the heater has been damaged or dropped.
5. Only qualified service personnel should service this water heater. Contact Raritan Technical Support for repairs.

Link to online
Warranty
Registration

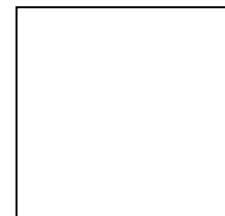

Model and Serial#:

Please have this available if support is needed.



MAINTENANCE

Following installation, temperature and pressure relief lever **MUST** be operated by lifting lever up **AT LEAST ONCE A YEAR** to ensure that the water ways are clear. Certain naturally occurring mineral deposits may adhere to the valve, rendering it unoperative. When manually lifting the lever up, water will discharge and precautions must be taken to avoid contact with hot water and to avoid water damage. **BEFORE** lifting lever up, check to see that a discharge line is connected to this valve directing the flow of hot water from the valve to a proper place of disposal, otherwise personal injury from hot water or steam may result. If no water flows, valve is inoperative. **TURN OFF THE WATER HEATER AND REPLACE THE VALVE IMMEDIATELY.**

If a backflow preventer such as a check valve is installed in cold water line and temperature and pressure valve discharges a cup of water per 10 gallon capacity of water heater during heating, reason for this occasional discharge is thermal expansion of water in closed system. An expansion tank should be installed in cold water line after check valve to correct such occasional discharge or dripping of temperature and pressure valve (See FIG 2).

Inspection of Anode and proper winterization is required of the Raritan Water Heater. Periodic visual inspection is recommended to be sure connections are tight, wires are not frayed and the unit is properly grounded. **DO NOT** use solvents to clean heater jacket. Incorporate this inspection into commissioning procedure in spring and winterizing procedure in fall.

A removable magnesium Anode is integral with the hot water discharge fitting. The Anode should be checked frequently depending on hardness of water by removing it from the water heater. Initially after installation, check within a year and depending on water quality frequency can be reduced to every 3 to 5 years. If the Anode diameter is less than 3/8" (9.5 mm), it should be replaced. If discoloration, unusual smell or taste develop in the water, inspect or replace Anode. The Anode is replaceable as a unit and may be ordered from Raritan dealers or from the factory. Please specify part number 1790610 for 6 gallon model and part number 1790010 for 12 and 20 gallon models.

REPLACING THE ANODE IN RARITAN WATER HEATERS

1. Turn off electric power to water heater.
2. Turn off water supply/pressure pump and open faucets to bleed pressure from water system. When water stops, close faucets.
3. Open pressure and temperature relief valve to allow water level in water heater to drop below level of valve.

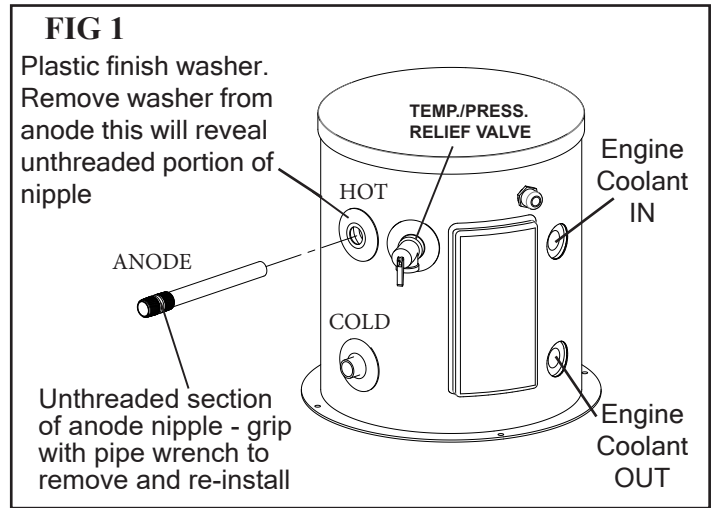

4. When water stops flowing out, remove any piping or fittings from hot water "out" nipple fitting (see FIG 1).
5. Remove plastic finish washer to reveal unthreaded area of nipple. Remove nipple with pipe wrench. Note that magnesium rod extends well into water heater and adequate clearance must be available to remove it. 11" for 6 gallon tanks and 16" for 12 and 20 gallon tanks.
6. Apply pipe PTFE thread compound or thread tape to new anode and screw into water heater tank. Tighten securely with pipe wrench. Re-connect all external plumbing.
7. Close temperature and pressure relief valve and turn on water supply/pressure pump.
8. When water system is up to pressure, check for leaks, then restore electric power.

REPLACING THE THERMOSTAT

WARNING: Danger of shock. Be sure to turn power off.

Use ONLY Raritan replacement thermostat (#WH16 ignition protected).

1. Remove access panel to thermostat and element.
 2. Remove cover (personnel protector).
 3. Unscrew the neutral and hot wires from the heating element with a Phillips screw driver.
 4. Cut the incoming black (HOT) and white (NEUTRAL) wires. Pull tabs of thermostat mounting bracket forward and lift thermostat out.
 5. Install new thermostat.
 6. Strip incoming wires, exposing 5/16" (8mm) of wire.
 7. Crimp neutral wire supply to white wire and hot wire supply to black wire (series connector provided with new thermostat). If disconnected, re-connect green ground wire to ground screw on bracket.
 8. Connect screw ring terminals of white and black wires on lower side of thermostat to studs of the element.
 9. Reinstall personal protector panel.
- NOTE: Check for leaks before proceeding.**
10. Replace access panel.
 11. Turn on AC power.

WINTERIZING

Before beginning winterizing, be sure the power is turned off to the water heater. Open all hot water taps on the boat to relieve the pressure and allow cold water to cool the water in the system. Remove both lines from the heater and allow it to drain. After it has drained, blow it out with air pressure, if available. Pour a quart of nontoxic antifreeze (propylene glycol) into the hot water fitting of the tank using a funnel and short length of hose. **Be sure power remains off until spring.**

When recommissioning in the spring, run water long enough to ensure that all antifreeze has been flushed out and tank is filled **BEFORE TURNING ON POWER**. Heat exchangers are winterized in conjunction with the boat's engine cooling system.

INSTALLATION

Materials Required for Installation (not included with water heater):

Plumbing: 3/4" NPT "Tee", check valve, expansion tank, drain valve, PTFE tape, vacuum relief valve and shut-off valve. For hot water connections use hose or plastic tubing rated for hot water use. If system will be used with dockside/shore water supply, a pressure regulator valve, set to match boat pressure system is also required. See FIG 2 for typical installation.

Electrical: Circuit breakers, stranded cable, wire crimp terminals and wire supports/straps (See table 2 on page 5 for breaker and wire sizes).

Hardware: Four 5/16" (8mm) stainless steel bolts or lag bolts, flat washers and hose clamps. For 12 and 20 gallon models: stainless steel straps and fasteners.

Tools needed: Pipe wrench, screw driver, wire crimping tool, nut driver and wrench(es) for mounting bolts or lag bolts.

MOUNTING THE HEATER

1. Select an area where the heater will not be subjected to water spray (especially salt water).

NOTE: Access or hatch must be large enough for future servicing and/or replacement.

2. Position heater so that electrical cover plates, plumbing nipples and heat exchanger fittings are easily accessible.
3. Using the four mounting holes provided, securely mount heater to deck or other sturdy flat area. Stainless steel 5/16" (8mm) bolts or lag bolts with flat washers should be used to properly support the strain of a full unit while the boat is rocking.

Raritan 12 gallon and 20 gallon water heaters require auxiliary bracing, when the boat is in heavy seas. This is also recommended for the 6 gallon models if excessive heeling and pitching is expected. See FIG 4a (page 6) for optional bracing.

PLUMBING

CAUTION: To reduce the risk of excessive pressure and temperature in this water heater, temperature and pressure sensitive protective equipment must be installed that meet the requirement of local codes. A device MUST NOT be installed unless it is certified by a nationally recognized testing laboratory and meets the requirements for Relief Valves and Automatic Shut-off Devices for Hot Water Supply Systems, ANSI Z21.11-1979. The relief valve must not be blocked or restricted under any circumstances.

For hot water connections use only piping, hoses, tubing, fixtures and connectors rated for hot water use.

Avoid sharp bends and 90° ells in the plumbing wherever possible, as they reduce the water flow. Should copper fittings be desired, DO NOT apply direct heat to the 3/4" nipples protruding from the heater. They contain a nonmetallic lining which will be destroyed by heat. Solder fittings first, then attach to water heater.

Refer to FIG 2 for typical water heater installation example.

1. Install Temperature and Pressure Relief Valve in area marked "OPENING FOR TEMPERATURE AND PRESSURE RELIEF DEVICE." Valve is included in box separate from the heater. Use PTFE tape on the threads.

WARNING: Discharge line shall be installed to allow complete drainage of both the Temperature and Pressure Relief Valve and discharge line.

FIG 2 Typical Hookup for Water Pressure System with Raritan Water Heater

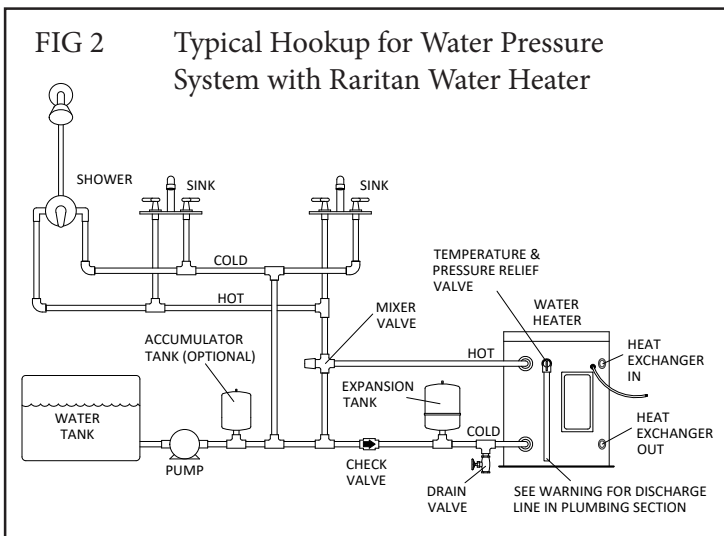

- The discharge line must pitch downward from the valve and terminate with a 6" (152 mm) air gap above the maximum bilge water level. Excessive length, more than 30 feet (9.14 m), use of more than four elbows/bends in discharge piping or a reduction of discharge line size will cause a restriction and reduce discharge capacity of relief valve. NO shutoff valve shall be installed in the discharge line of the temperature and pressure relief valve.

NOTE: Discharge line from relief valve can be discharged overboard if above requirements are met.

- If there is a dockside/shore connection inlet and if discharge of temperature and pressure relief valve is not connected overboard as per # 2 above, the relief valve plumbing shall discharge into the bilge above the normal accumulation of bilge water, and a bilge high water alarm shall be installed per ABYC H-22, *Electric Bilge Pump Systems*.

WARNING: HAZARD OF FLOODING:

If water heater is supplied by dockside/shore water connection, then do not leave water heater unattended as a failure in temperature and pressure relief valve can flood the boat. Shut off dock side connection while leaving boat unattended.

- An expansion tank of proper capacity (see Table 1) should be installed in the cold water line to avoid pressure buildup due to thermal expansion of water (See FIG 2 on page 3).

Table 1

Water heater capacity	Expected thermal expansion	Recommended minimum expansions tank size
6 Gallons	11.6 oz	24 oz
12 Gallons	23.2 oz	24 oz
20 Gallons	38.6 oz	½ gallon or higher

- Thermostatic mixing valve should be installed before point of use to limit the water temperature to maximum of 125° F (52° C). For more information, see your qualified technician.
- Secure all lines to the boat's structure at frequent intervals.
- For models with heat exchangers see FIG 5 on page 7

WARNING: Before working on unit, be sure that the circuit breaker is off.

ELECTRICAL PREPARATION

All wiring should be done in accordance with ABYC E8, AC wiring standard.

- Install a 15 amp (10 amp for 240V AC or 20 amp for model #17120203 and 17200203) Circuit Breaker in the 120V AC service line to the water heater.
- Use ONLY STRANDED #12-3 (#10-3 for model #17120203 and 17200203) cable to the heater. NEVER use solid (ROMEX-type) wire on a boat; vessel vibration causes breakage due to metal fatigue (see U.S. Coast Guard CFR Title 33, Part 183.423).
- Secure wire at intervals of 18" (45.7cm). Allow about 24" (61cm) of extra wire to make necessary connections.

WIRING

- Remove access panel.
- Strip outer insulation off the cable (long enough for green ground wire to reach grounding screw) exposing three insulated wires.
- Loosen strain relief connector by turning counterclockwise and insert cable. Then expose approximately 5/16" (8mm) of bare wire on each of the three pieces of stranded wire.
- Grounding:** Join the AC grounding conductor (green), using the crimp-on terminal end (provided), to the screw at the bottom of the thermostat bracket.
- Attach black (HOT) and white (NEUTRAL) wires to thermostat per FIG 3. Use crimp-on terminal ends (provided) to ensure a secure installation. **Do not** use solder as it will cause the wire to become solid rather than stranded (making it susceptible to breakage due to vibration).

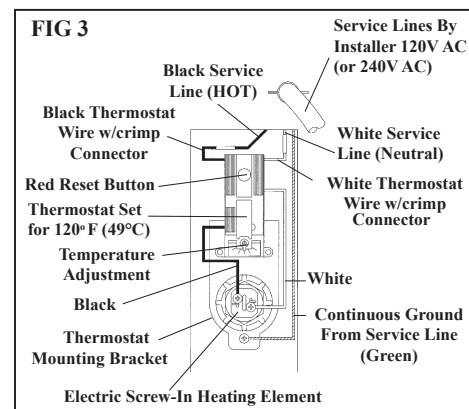

- Tighten strain relief by turning it clockwise.

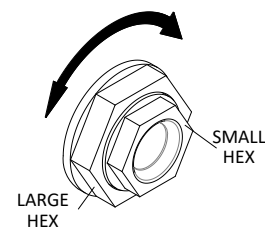

Table 2

Model (Gallons)	Voltage and Wattage	Circuit Breaker	Wire Size
6, 12, 20	120 V / 1250 W	15 Amps	#12-3 Stranded Cable
6, 12, 20	240 V / 1250 W	10 Amps	#12-3 Stranded Cable
12, 20	240 V / 4500 W	20 Amps	#10-3 Stranded Cable

CAUTION: To prevent burnout of heating element do not turn on electricity. Follow start-up procedure.

WARNING: Be sure power is off before start-up procedure is performed.

START - UP

1. After all plumbing lines have been properly installed and secured, open all hot water taps and turn on the pressurized water supply.
2. Allow water to run a few minutes until all air is expelled and all outlets flow clear of air. Failure to expel air may cause an air pocket in the tank. This will cause the heating element to burn out, as it will not be in contact with water. All the air may not be expelled after purge, however over a period of time (two weeks) the remaining air in the tank will be absorbed by the water.
3. Check for leaks.
4. Replace electrical access cover and turn on power.

TROUBLESHOOTING		
WARNING: If temperature and safety valve is leaking it must be replaced. Reference: www.raritaneng.com/tech support/repair shop		
PROBLEM	CAUSE	CORRECTION
A. Water does not get hot.	A1. No power at the heater. A2. Malfunctioning heating element or thermostat.	A1. Be sure circuit breaker or switch is turned on and wiring is not broken or disconnected. A2. Check red reset button. Remove electrical access cover. If red reset button has popped out, it must be reset by depressing it, to restore power. If water is not warm within 30 minutes check to be sure there is power at the thermostat. This can be done by checking voltage at the top of the thermostat, between the two top wires (on left and right side of thermostat). If system voltage is present, check for power at the heating element. If power is available at heating element, heating element is burned out. If power is not available at heating element, replace thermostat.
B. Relief valve opens and releases hot water.	B1. Malfunctioning thermostat. B2. If heat exchanger is in use, the engine operating temperature may be too high. B3. Higher range relief valve may be needed if pressure system is near 60 psi B4. Improperly installed or missing plumbing components.	B1. Check thermostat operation and replace it if bad. Use qualified electrician if you cannot determine whether or not thermostat is operational. B2. If heater is equipped with a heat exchanger, and the relief valve opens while engine is running, check your setting and installation per Fig.#5. B3. Replace Pressure Relief Valve (part# WH3A). B4. Verify all recommended components (hot water expansion tank and check valve are in proper locations) are installed properly.
C. Constant dripping of relief valve.	C1. Foreign matter lodged in the seat of the relief valve. C2. Check valve installed incorrectly in cold water line. C3. Higher range relief valve may be needed if pressure system is near 60 psi. C4. Improperly installed or missing plumbing components.	C1. Replace relief valve. C2. Check valve does not allow for the thermal expansion of water. Re-plumb per Fig. #2 using expansion tank. C3. Replace Pressure Relief Valve (part# WH3A). C4. Verify all recommended components (hot water and check valve are in proper locations) are installed properly.

FIG 4a SUPPORT BRACKET OPTION FOR 12 and 20 GALLON WATER HEATER

Materials: 1" (2.5cm) full cut wood for (4) sides of frame; top is made of 3/4" (1.9cm) marine plywood.
All parts are screwed together.

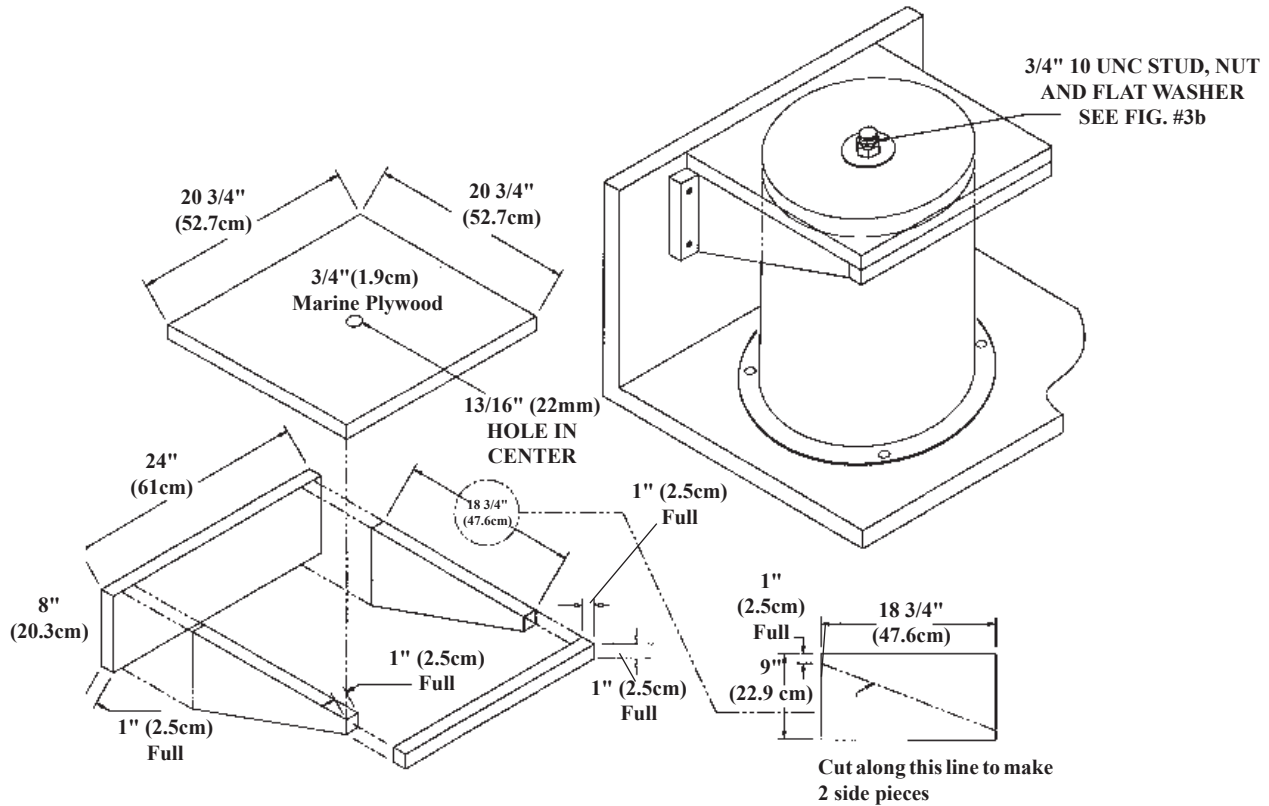
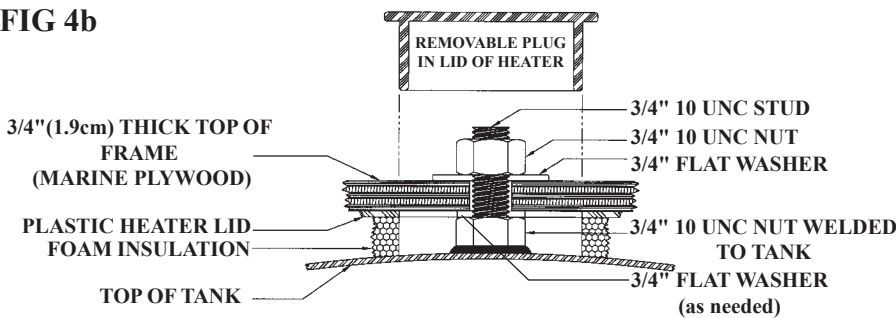

FIG 4b



PART NUMBERS

SERVICE AND REPLACEMENT PARTS

Replacement parts may be ordered through your local Raritan dealer or directly from the factory. Some parts may be ordered at www.raritaneng.com. When ordering please state part number, description and quantity required. With some parts you may need to know voltage. Questions or problems may be referred to Raritan's Technical Support.

WH1A-S	Heating Element, 120V (screw-in) with gasket
WH1B-S	Heating Element, 240V (screw-in) with gasket
WH1D-S	Heating Element, 4500 watt/240V (screw-in) with Gasket (for models 17120203 with heat exchanger and 17201203 without heat exchanger)
WH1GS	Heating Element Gasket
WH3	Temperature and Pressure Relief Valve, 75 PSI
WH3A	Temperature and Pressure Relief Valve, 100 PSI
WH16	Thermostat
1790610	Anode 6 gallon
1790010	Anode 12 and 20 gallon

Parts may be ordered at www.raritaneng.com

FIG 5

HEAT EXCHANGER

The following information is only a general guideline and any installation is made at the risk of the installer. No responsibility to Raritan Engineering Company, Inc. is to be presumed or implied from these general instructions.

Two 3/4" NPT female threads are provided in the heat exchanger for connection to hoses or piping from engine cooling system. Because of the diversity of marine cooling configurations, it is not possible to provide universal installation instructions; the installer **MUST** follow the engine manufacturer's recommendations.

NOTE: If heat exchanger is higher than engine coolant pump, check with engine manufacturer for allowable height of coolant lines.

To determine the proper setting of the gate valve (4), the engine should be operated at full throttle with the gate valve wide open. When the engine temperature has stabilized, gradually close the valve until the engine temperature begins to rise. The valve should then be reopened enough to establish the proper engine operating temperature. Engine temperature should be monitored to verify that the entire cooling system is functioning properly. Open valve (4) if heated water temperature exceeds 120° F (49°C).

THE FOLLOWING DIAGRAM IS INTENDED ONLY AS A GENERAL GUIDELINE TO SHOW HOW A PORTION OF THE ENGINE COOLANT MAY BE DIVERTED TO THE HEAT EXCHANGER:

WARNING: If coolant water from engine is salt water, Heat Exchanger must stay flooded with water at all times. Cycling between dry and full will corrode heat exchanger and void warranty.

LEGEND:

1. Hottest water from engine (full flow).
2. Pipe tee; full flow on run, 3/4" NPT on branch.
3. Hose to hot water heat exchanger.
4. Gate valve sized to permit full flow of coolant.
5. Pipe tee; full flow on run, 3/4" NPT on branch.
6. Hose from hot water heat exchanger.
7. Full flow return to engine cooling system.

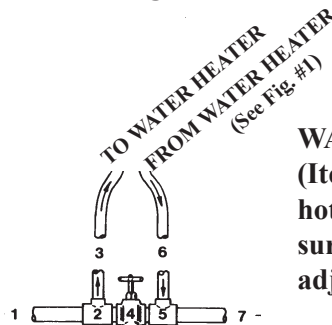

WARNING: Piping and gate valve (Item #4) may become extremely hot while engine is operating. Be sure to wear heavy gloves when adjusting gate valve.

SPECIFICATIONS

Electrical Recovery Rate = 13 gallons (49.2 liters) per hour

Maximum Operating Pressure: Tank: rated at 150 psi (1034kPa)

With Temperature and Pressure Valve Installed: 50 psi (345kPa)

NOTE: If working pressure is 60 psi (414 kPa) then a temperature and pressure valve rated at 100 psi (790 kPa) is available (part WH3A)

Amps: 10 (120V AC), 5 (240V AC) or 18.75 (240V AC) for model 17120203 and 17200203

Thermostat: Adjustable: Factory Set to 120°F (49°C) (Effects AC Power only)

Anode: Magnesium

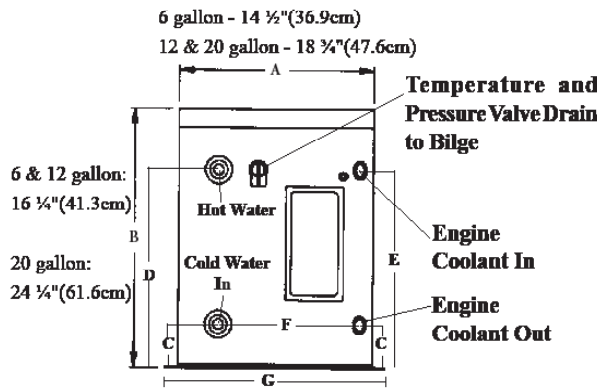

Model #	Size	Capacity	A & B	C	D	E	F	G	Ship Wt.
1706XX	6-gal(22.71liters)	6 gallons	see above	3 3/8"(8.6cm)	11"(28cm)	10 1/4"(26cm)	12 1/2"(31.8cm)	16 1/2"(42cm)	37lbs(16.8kg)
1712XX	12-gal(45.4 liters)	11 gallons		3 3/8"(8.6cm)	11"(28cm)	10 1/4"(26cm)	12 3/8"(31.4cm)	20 1/2"(52cm)	55lbs(24.9kg)
1720XX	20-gal(75.7 liters)	17.5 gallons		3 3/8"(8.6cm)	18 3/4"(47.6cm)	10 1/4"(26cm)	12 3/8"(31.4cm)	20 1/2"(52cm)	68lbs(30.8kg)

Note: 12 gallon with HE is 10 gallon capacity

XX = 01(120V) or 02(240V) without Heat Exchanger, 11(120V) or 12(240V) with Heat Exchanger

LIMITED WARRANTY

Raritan Engineering Company warrants to the original purchaser that this product is free of defects in materials or workmanship from the product's date of purchase and should this product prove defective by reason of improper workmanship and/or materials, Raritan shall, at its sole option, repair or replace the product. For a period of five years from the date of purchase, Raritan warrants the inner tank against leaks provided the anode in the hot water outlet is checked annually. Raritan warrants all other parts for a two year period.

1. TO OBTAIN WARRANTY SERVICE, Consumer must deliver the product prepaid, together with a detailed description of the problem, to Raritan at 530 Orange St., Millville, N.J. 08332. When requesting warranty service, purchaser must present a sales slip or other document which establishes proof of purchase. THE RETURN OF THE OWNER REGISTRATION CARD IS NOT A CONDITION PRECEDENT OF WARRANTY COVERAGE. However, please complete and return the owner Registration Card so that Raritan can contact you should a question of safety arise which could affect you.

2. THIS WARRANTY DOES NOT COVER defects caused by modifications, alterations, repairs or service of this product by anyone other than Raritan; defects in materials or workmanship supplied by others in the process of installation of this product; defects caused by installation of this product other than in accordance with the manufacturer's recommended installation instructions or standard industry procedures; physical abuse to, or misuse of, this product. This warranty also does not cover damages to equipment caused by fire, flood, external water, excessive corrosion or Act of God.

3. ANY EXPRESS WARRANTY NOT PROVIDED HEREIN, AND ANY REMEDY FOR BREACH OF CONTRACT WHICH BUT FOR THIS PROVISION MIGHT ARISE BY IMPLICATION OR OPERATION OF LAW, IS HEREBY EXCLUDED AND DISCLAIMED. ALL IMPLIED WARRANTIES SUCH AS THOSE OF MERCHANTABILITY AND OF FITNESS FOR A PARTICULAR PURPOSE, IF APPLICABLE, AS WELL AS ANY IMPLIED WARRANTIES WHICH MIGHT ARISE BY IMPLICATION OF LAW, ARE EXPRESSLY LIMITED TO A TERM OF TWO YEARS. SOME STATES DO NOT ALLOW LIMITATIONS ON HOW LONG A LIMITED WARRANTY LASTS, SO THE ABOVE LIMITATION MAY NOT APPLY TO YOU.

4. UNDER NO CIRCUMSTANCES SHALL RARITAN BE LIABLE TO PURCHASER OR ANY OTHER PERSONS FOR ANY SPECIAL OR CONSEQUENTIAL DAMAGES, WHETHER ARISING OUT OF BREACH OF WARRANTY, BREACH OF CONTRACT, OR OTHERWISE. SOME STATES DO NOT ALLOW THE EXCLUSION OR LIMITATION OF INCIDENTAL OR CONSEQUENTIAL DAMAGES, SO THE ABOVE LIMITATION OR EXCLUSION MAY NOT APPLY TO YOU.

5. No other person or entity is authorized to make any express warranty, promise or affirmation of fact or to assume any other liability on behalf of Raritan in connection with its products except as specifically set forth in this warranty.

6. This warranty gives you specific legal rights, and you may also have other rights which vary from state to state.



530 Orange Street
Millville, NJ 08332 USA
Telephone: 856-825-4900
FAX: 856-825-4409
www.raritaneng.com

Specifications subject to change without notice.

Printed in USA