



## Models EST12 and EST24 Installation, Maintenance and Operation Instructions

THE FOLLOWING ARE CAUTIONARY STATEMENTS THAT MUST BE READ AND FOLLOWED DURING INSTALLATION, MAINTENANCE AND OPERATION

**WARNING:** *Raritan Engineering Company, Inc. recommends that a qualified person or electrician install this product. Equipment damage, injury to personnel or death could result from improper installation. Raritan Engineering Company, Inc. accepts no responsibility or liability for damage to equipment, or injury or death to personnel that may result from improper installation or operation of this product.*



**WARNING: HAZARD OF SHOCK AND FIRE** - Always use recommended fuse/circuit breaker and wire size. Motors used with this product are “Ignition Protected”. They are not however, explosion-proof. **DO NOT** run continuously for more than 30 seconds.



**WARNING: HAZARD OF FLOODING** - Always shut off sea cocks before leaving boat unattended. Double clamp all hose fittings below the waterline, check hose clamps frequently for integrity.



**WARNING:** *The electroscan® operates on an Electrochemical principle. Introduction of any substance other than salt water, human waste, Raritan C.P. or toilet tissue may cause heat build up and extensive damage. If any other substance is introduced by accident, the electroscan® must not be turned on until entire system is flushed out with water.*



### Description

**electroscan®** is a U. S. Coast Guard Certified Type I Marine Sanitation Device (MSD) for use on inspected and uninspected vessels 65' [19.8 m] and under. It must be operated within areas that are not declared a Federal No Discharge Zone (NDZ) by the U.S. Environmental Protection Agency (EPA). This is applicable for all U.S. territorial waters inside the three mile limit and within 9 nautical miles in the Gulf of America. Other countries - check with local authorities.

**electroscan®** is designed for recreational use and accommodates most marine toilets\*. It can be used with one or, in certain instances, two toilets (contact technical support). The electroscan® is available in 12 VDC or 24 VDC.

The system consists of a Control Unit, LCD Display, System Status Panel and Treatment Unit.

\*for use with the VacuFlush® marine toilet manufactured by Sealand Technology, Inc., (See Application note L286)  
VacuFlush® is a registered trademark of Sealand Technology, Inc.

### electroscan®



856-825-4900  
www.raritaneng.com

## Single Button operation -

Both toilet and electroscan® are operated by one of the following options:

### Option 1: Toilet Flush Control - (recommended)

Flushing toilet will activate treatment cycle. Flush toilet as often as necessary until system status green light begins to blink, flush must not exceed 1.5 gallons [5.7 L].

### Option 2: System Status Panel

"START/STOP" button activates both the toilet and treatment cycle.

**NOTE:** Toilet flush time is factory pre-set for 10 seconds and is adjustable, see "setting toilet flush time" on page 3.

## Independent Button operation

For use with manual flush toilets or with electric toilets that are activated independently from electroscan® system: Press the System Status Panel "START/STOP" button prior to flushing the toilet. Flush only as much as needed to clear the bowl of waste or until the system status green light begins to blink.

Each flush must not exceed 1.5 gallons [5.7 L].

## Automatic Flush Sensor operation (31-605)

If purchased separately and installed, flushing a manual toilet will automatically start electroscan® cycle.

## To Stop Treatment Cycle

Pressing "START/STOP" again stops the treatment cycle, If wired per **Option 2** it will also stop the toilet from flushing.

## NOTES:

- 1) **Maximum Treatment Cycle Volume:**  
1.5 gallons [5.7 L] per cycle.
- 2) **Operating with red light for extended periods will damage electrode and void warranty.**

## Salt Feed System Options

### IMPORTANT:

The electroscan® requires proper ocean salinity (3.5% salt) to operate correctly. If the unit is used in low-salinity conditions, such as fresh or brackish water, a salt feed tank must be installed. Operating the unit without adding salt in these conditions will shorten the life of the electrode and void the warranty.

The following are available to purchase:

### 2 Gallon [7.6 L] Salt Feed Tank (31-3001):

**NOTE:** For use with raw water supplied toilets with brackish and lower salinity supplied toilets.

Tank must be filled with a saturated salt solution which is dispensed via a T-check valve into incoming water. One system per toilet. For use in slightly brackish water.

### 4 Gallon [15.2 L] Salt Feed Tank with Pump:

**NOTE:** For use with pressurized fresh water toilets and raw water supplied toilets:

### 32-3006 (12 VDC) and 33-3006 (24 VDC):

The tank must be connected to a pressurized fresh water supply and filled with solar salt. The pump is controlled by the Control Unit.

This system is designed for use only with the electroscan®. One system is required per electroscan®.

This method provides the most accurate operation because the actual operating conditions of the electroscan® determine the amount of saturated salt solution delivered.

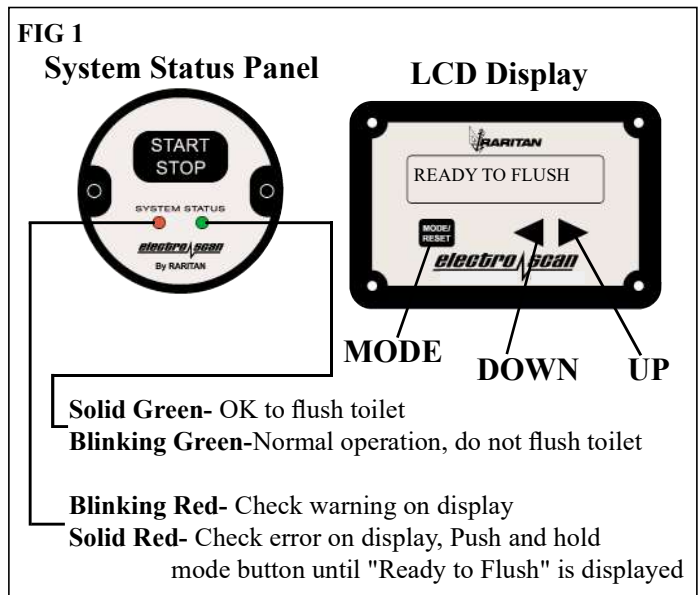

The **electroscan®** has four components:

- **System Status Panel (FIG 2)**- Begins treatment cycle and if wired, flushes an electric toilet at the same time.
- **Control Unit (FIG 3)**- Systems central control. This unit contains three boards:
  - 1) **Main:** Power and logic.
  - 2) **Microprocessor/Memory:** System program and stores operation records.
  - 3) **I/O:** Accessory connections.
- **Treatment Unit** - Two chambers and electrode pack that temporarily converts saltwater into a powerful bactericide for the duration of the treatment cycle.
- **LCD Display (FIG 4)**- Provides information during treatment cycle and summary of historical data. Also contains RESET button if system error occurs.

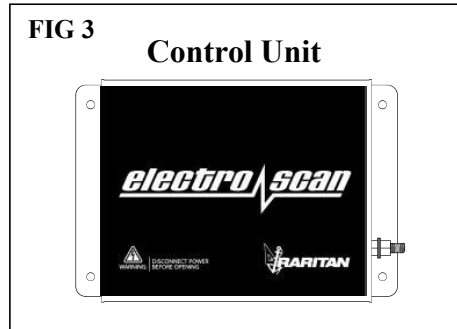
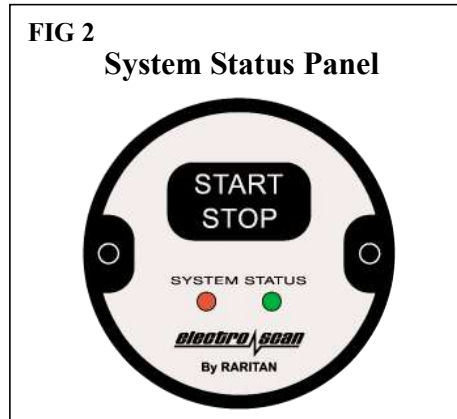

**Setting time and date on LCD Display (FIG 4):**

**NOTE:** When unit is not in cycle

- Scroll to "TIME SCREEN" using < and > keys.
- Hold "MODE" button until digits flash.
- Use < and > button to set hour in 24 hour time.
- Push "MODE" again for next digits (minutes).
- Use < and > to set minutes.
- Repeat above until time and date are set.
- Use < or > to move to next screen when no digits are flashing.

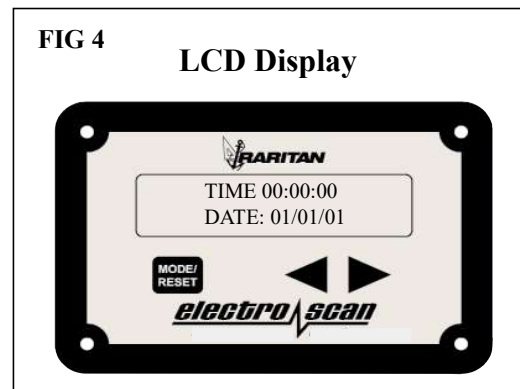

**Setting toilet Flushtime on LCD Display (FIG 5):**

**NOTE:** When unit is not in cycle

- Scroll to "FLUSHTIME" screen using < and > keys.
- Hold "MODE" button until digits flash.
- Use < or > keys to set time in seconds for toilet 1.
- Repeat above for toilet 2 ("FLUSHTIME 2").

**Toilet only flush:**

**Use only for servicing, storage or recommissioning. It is illegal to discharge untreated sewage in U.S. waters.**

**NOTE:** When unit is not in cycle

- Scroll to "FLUSHTIME" (1 or 2) screen using < or > keys.
- Hold "MODE" button and press < or > key.
- Toilet will flush for set time.

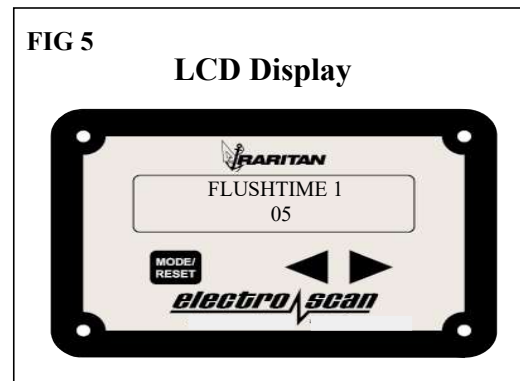

Most operation and troubleshooting information is displayed on the LCD display panel. Following is the description of display screens and what they mean (see Troubleshooting).

**RED LED blinks for warning and is solid for errors**

Display	Panel LEDs		Status
	Red	Green	
READY TO FLUSH	○	○	Previous cycle ended normally. Ready for next cycle.
****WARNING**** VOLTAGE LOW	●	○	Previous cycle completed with low voltage. Ready for next cycle, low voltage should be corrected.
****WARNING**** AMPS < 14	●	○	Previous cycle completed with low electrode amps. Ready for next cycle, low amps should be corrected.
**PRETREATMENT** VOLTAGE= 100%	○	●	Unit is in "PRETREATMENT" cycle after start, "VOLTAGE" displayed.
***TREATMENT*** VOLTAGE= 100%	○	●	Unit goes to "TREATMENT" cycle after pretreatment for 120 seconds, voltage and amps are displayed alternately.
***TREATMENT*** AMPS = 15	○	●	
****WARNING**** AMP = 10	●	○	During the treatment cycle if electrode amps drop below 14, "WARNING" is displayed, and cycle is extended up to 240 seconds.
****WARNING**** VOLTAGE < 87%	●	○	During the entire cycle if voltage drops below 89% of full battery voltage, "WARNING" is displayed, cycle continues.

**Treatment terminates in ERROR condition for reasons listed below. To clear error condition after corrective action is taken, hold "MODE/RESET" button on display until "READY TO FLUSH" is displayed.**

*****ERROR**** LOW VOLTAGE	●	○	Voltage was less than 83% of full voltage during the cycle; check battery, connections and wire sizes.
*****ERROR**** LOW ELECTROD AMP	●	○	Electrode amps were lower than 7 amps, check salt, clean electrode per electrode cleaning page 5, check all connections.
*****ERROR**** MIX MOTOR OVERLD	●	○	Mixer motor amps high, refer to troubleshooting.
*****ERROR**** MAC MOTOR OVERLD	●	○	Macerator motor amps high, refer to troubleshooting.
*****ERROR**** ELECTROD OVERLD	●	○	Electrode amps were higher than 28 amps during fresh water operation, check for excessive salt, shorted electrode, wiring.
*****ERROR**** POS FUSE BLOWN	●	○	Positive/Negative fuse on I/O connection board is blown due to some external short, check toilet solenoid type, wiring to solenoid.
*****ERROR**** NEG FUSE BLOWN	●	○	Solenoid (relay) to toilet must be isolated coil type or Raritan solenoid part #CDS12 (12 VDC).

**Following screens can be seen by scrolling up (>) and down (<) keys. These screens display historical summaries of the data and allow setting of clock and flush timers**

TIME 00:00:00 DATE: 01/01/00	FLUSHTIME 1 05	FLUSHTIME 2 10	NUMBER OF CYCLES 00100	CYCLE W/O LST 000
NUMBER OF RESETS 00	LOW AMP 14-18 000	LOW AMPS 7-14 000	LOW AMP SHUTDOWN 000	LOW VOLTS < 90% 05
LOW VOLT < 83% 01	LOW VOLT SHUTDOWN 05	MIN TEMPERATURE 20° F	MAX TEMPERATURE 90° F	

## Cleaning Instructions

**IMPORTANT:** Do not use bowl cleaners that contain ammonia, ethyl acetate, phosphoric acid or concentrated chlorine bleach.

**WARNING:** If the treatment system is activated with these cleaners, serious damage to the system will occur.

Raritan C.P. (1PCP32) - Cleans Potties, a bio-enzymatic bowl cleaner, will keep the bowl clean and fresh smelling. It is the only factory-recognized cleaning product that may be used in the toilet. A mild soap and water solution can be used for all other components.

DO NOT ADD ANY OTHER CHEMICALS OR CLEANING PRODUCTS TO THE TOILET OR THE TREATMENT SYSTEM.

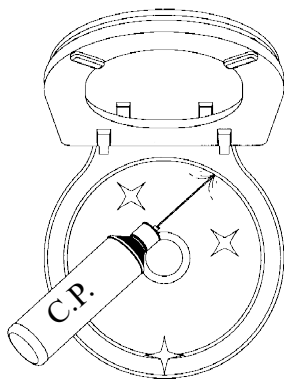

## Treatment/Electrode Cleaning

**NOTE:** Cleaning is recommended every SIX MONTHS or if red light and warning for low electrode amps are always on during treatment cycle.

**WARNING:** electroscan® must NOT be activated without disconnecting electrode and motor wires while cleaning solution is in the system.

## MURIATIC ACID TREATMENT:

1. Activate the electroscan® and flush toilet several times, allowing all waste to be treated.
2. Turn off water supply and flush toilet as dry as possible.

**NOTE:** Check toilet manufacturer's instructions to ensure that no components are damaged.

3. Turn Power off.
4. Disconnect red, white and orange wires at electroscan® control box.
5. Based on a 30-35% concentration, if lesser percentage is used, adjust mixture accordingly. In plastic bucket, combine 1.5 pints [.7 L] of muriatic acid with 3 gallons [11.4 L] of fresh water.
6. Carefully pour solution into the toilet and flush until bowl is as dry as possible.
7. Pour 1 gallon [3.8 L] of additional fresh water into bowl to dilute any acid remaining.
8. Allow to stand for a **maximum** of 45 minutes.
9. Turn on water supply and flush only the toilet a minimum of 10 gallons [38.0 L] of water to dilute and discharge muriatic acid solution. See Page 3 OPERATION: Toilet only flush (if using one button operation)
10. Reconnect wires and turn power on to electroscan®.

## Recommended Visual Inspection

- ✓ No leaks at hose connections
- ✓ Hose clamps
- ✓ Condition of hoses
- ✓ Seacocks
- ✓ Condition of wires and connections

## Storage

Short Term - If system will not be used for a week, flush toilet with treatment cycle several times.

Long Term - If system will not be used for several weeks, flush toilet with treatment cycle several times. Then flush fresh water into system.

Prior to use - flush toilet several times to re-fill treatment unit with ocean salinity salt water. Refer to Recommissioning & Start-Up to initialize the system after storage (page 6).

## WINTERIZING

### IMPORTANT

- **Improper winter lay up is a major cause of failure due to freezing or buildup.**
1. Flush toilet with treatment cycle several times to clean out hoses and tank.
  2. Turn off water supply and flush toilet as dry as possible.

**NOTE: Check toilet manufacturer's instructions to ensure no damage is done to any components.**

3. Turn off power and disconnect wires to electroscan®.
4. Close seacocks.
5. Slowly open cross-over plug (FIG 6).

**Caution:** Open plug slowly as unit may be under pressure.

5. Using a pump and small tube, remove water from each side of partition in Treatment Unit through crossover plug.
6. Disconnect and drain hoses.

### Recommissioning & Start-Up

1. Reconnect hoses and open seacocks.
2. Reconnect wires and turn power on.

**NOTE:** electroscan® Treatment Unit must be filled with **ocean water salinity**, 3.5% salt water before activating a cycle.

3. Flush toilet using one of the following methods to fill the Treatment Unit with salt water.

**NOTE:** When unit is not in cycle

- Using LCD Display, scroll to Flushtime (1 or 2) screen using < or > keys. Hold "mode" button and press < or > key. Toilet will flush for set time.
- Separate operation - flush toilet allowing 3 gallons [11.4 L] of water to pass into electroscan®.
- If toilet operates electroscan® - you must disconnect power from electroscan® while flushing to allow 3 gallons [11.4 L] of water to pass into electroscan®.

**NOTE:** In fresh and brackish water operation, salt content of Treatment Unit must be ocean water salinity prior to using unit for treatment. Ocean water salinity is 3.5% or approximately 4 ounces of salt to 1 gallon of water [35 g/L].

4. Inspect all connections for leaks.
5. System is ready for use.

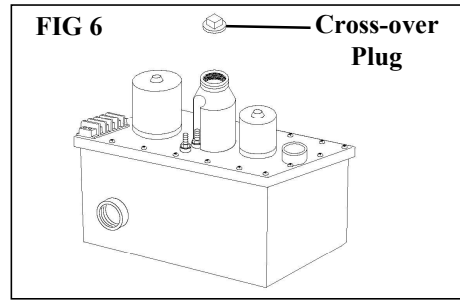

### How the Electroscan works -

This waste treatment system depends on the connected toilet to deliver and move wastewater into and through the treatment unit.

Each time the toilet is flushed, an equal amount of previously treated waste is discharged. The flushing action of the toilet moves wastewater through the electroscan® and out of the system.

Internal motors and cutting blades provide maceration and mixing. The treatment unit consists of two chambers. The first chamber macerates the waste to reduce particle size. The second chamber mixes the contents to ensure uniform treatment.

The treatment tank remains full at all times. With proper ocean salinity (3.5% salt), electricity applied to the electrodes produces a strong bactericide that kills viruses and bacteria.

When the system is activated, both motors start and run for the entire cycle. The user then has 35 seconds to flush the toilet. After 35 seconds, the electrodes are energized and the treatment process begins. This process lasts approximately 2 minutes, after which the wastewater is treated and ready for discharge during the next flush.

### Installation Guidelines

Install the treatment unit within 6 feet [1.8 m] of the toilet to reduce the possibility of odor caused by untreated wastewater remaining in the hose.

Longer hose runs are acceptable when using a high-quality sanitation hose such as Raritan Sani-Flex SFH or SFH1, and a toilet capable of pumping that distance, such as Raritan Atlantes, Raritan Marine Elegance, or Raritan SeaEra.

Contact Technical Support for installations exceeding 10' [3 m].

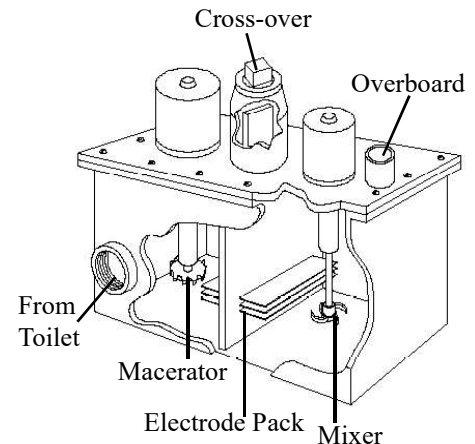

**U.S.C.G. Type I MSD Certification #159.015/107/3**

Maximum Roll/Pitch Angle: 30°  
 Maximum Temperature Exposure: 120° F [49° C]  
 Minimum Water Temp: 50° F [10° C]  
 Maximum Total Flush Volume: 1.5 gallons/flush [5.7 L/flush]  
 Maximum Cable Length for LCD Display: 15' [4.5 m]  
 Maximum Cable Length System Status Panel: 50' [15.24 m]

**NOTES FOR WIRING:**

- Distances are from source to unit and back to source.
- Recommended conductor wire minimum AWG [mm<sup>2</sup>] for 3% voltage drop.
- Recommended conductor sizes are based on 105°C rated insulation. Refer to ABYC Standards for other insulation ratings.

CONVERSIONS								
Wire - AWG to mm2								
AWG	16	14	12	10	8	6	4	2
mm <sup>2</sup>	1.5	2.5	4.0	6.0	10.0	16.0	25.0	35.0
Feet to Meters								
Feet	10	15	20	25	30	40	50	
Meter	3.1	4.6	6.1	7.6	9.2	12.2	15.2	

**Recommended Wire and Fuse/Circuit Breaker Size**

Units Voltage	Circuit Breaker/fuse size (amps)	Amp. draw @ nominal voltage	10 feet	15 feet	20 feet	25 feet	30 feet	40 feet	50 feet
12 VDC	60	37	6 AWG	6 AWG	4 AWG	4 AWG	2 AWG	2 AWG	1 AWG
24 VDC	50	27	10 AWG	8 AWG	6 AWG	6 AWG	6 AWG	4 AWG	4 AWG

**Electronic trip Overload settings**

	12 VDC Trip point / Fuse Maximum amperage	24 VDC Trip point / Fuse Maximum amperage
Mixer Motor	9 amps / 35 amps 5 amp draw	9 amps / 35 amps 4 amp draw
Electrode Pack	35 amps / 35 amps 25 amp draw	35 amps / 35 amps 22 amp draw
Macerator Motor	30 amps / 35 amps 20 amp draw	30 amps / 35 amps 16 amp draw

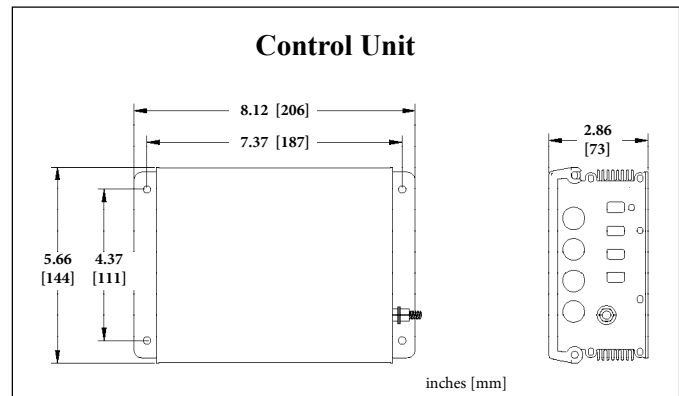
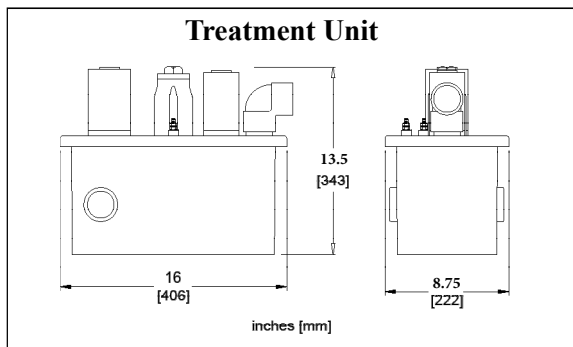
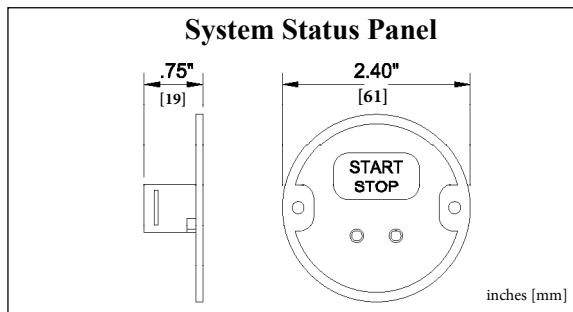
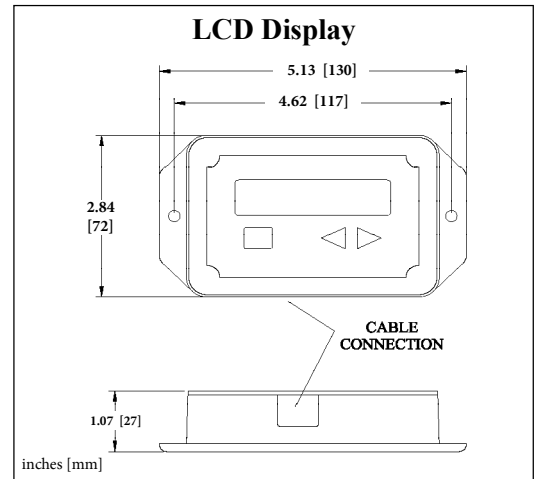

## Parts Included with the electroscan®

- 1 1/2" [3.8 mm] hose adapters (2)
- 1 1/2" [3.8 mm] NPT Intake Plug
- 90° 1 1/2" [3.8 mm] slip PVC fitting
- Treatment Unit
- System Status Panel, Control Unit, LCD Display, Cables
- Wiring Harness between Control Unit and Treatment Unit

## Optional Parts available for purchase:

- Dual Control - Part ESTDC
- Salt Feed Systems - See Page 2 for part #'s
- Manual Head Sensor (31-605) for automatic activation

## Parts Required (not included)

- PTFE tape or non-permanent thread sealing compound
- PVC Cement, PVC Cleaner
- 1 1/2" [3.8 mm] I.D. Sanitation Hose (Raritan part SFH)
- Hose clamps
- 1" [25 mm] x 1" [25 mm] wood strips and fasteners to secure to floor (wooden frame)
- 3/4" [19 mm] strapping
- Electrical connections, wire and fuse or circuit breaker
- Strain relief clamps

**NOTE: Discharge of raw, untreated sewage is prohibited in all U.S. waters inside the three mile limit except where the limit is nine miles. "Y" valves, if installed, must direct toilet discharge to a U.S.C.G. approved treatment system or holding tank and must be secured in that position while inside the three-mile limit.**

The EPA standards state that in freshwater lakes, freshwater reservoirs or other freshwater impoundments whose inlets or outlets are such to prevent the ingress or egress by vessel traffic subject to this regulation, or in rivers not capable of navigation by interstate vessel traffic subject to this regulation, marine sanitation devices certified by the U.S. Coast Guard installed on all vessels shall be designed and operated to prevent the overboard discharge of sewage, treated or untreated, or any waste derived from sewage. The EPA standards further state that this shall not be construed to prohibit the carriage of Coast Guard-certified flow-through treatment devices which have been secured so as to prevent such discharges. They also state that waters where a Coast Guard-certified marine sanitation device permitting discharge is allowed including coastal water estuaries, the Great Lakes and interconnected waterways, freshwater lakes and impoundments accessible through locks, and other flowing waters that are navigable interstate by vessels subject to this regulation (40 CFR 140.3)

## MOUNTING

### Treatment Unit and Control Unit

**WARNING: DO NOT locate in an area where ambient temperature exceeds 120° F [49° C]. (If toilet will be mounted lower than Treatment Unit contact Tech Support)**

**NOTE: CAUTION: Install Control Unit in a dry location. Do not expose to rain or spray.**

**IMPORTANT: Install Control Unit where it will be accessible after installation.**

1. Locate top of Treatment Unit at or below discharge of toilet and within 6' [1.8 m]. Longer runs require longer flush time to ensure all waste clears the line.
2. Make and secure mounting frame to flat surface.
3. Secure tank to frame using 3/4" [19 mm] mounting straps (not included) (FIG 11).

**NOTE: Placing a 3/8" [9.5 mm] rubber pad under tank will help to reduce vibration and noise.**

**NOTE: If the Control Unit cannot be installed within 30" [76 cm], see WIRING Treatment Unit Section of these instructions.**

4. Secure Control Unit within 30" [76 cm] of Treatment Unit

**NOTE: Cables supplied are 15' [4.5 m]**

### SYSTEM STATUS PANEL - cable can be extended up to 50' [15 m]

1. Locate in head compartment where system status lights will be visible.
2. Drill 1 1/2" [38 mm] hole for back of panel
3. Route cable between panel and Control Unit.
4. Plug cable into back of panel and Control Unit.
5. Mount panel using 2 screws.

### LCD DISPLAY - cable can not be extended

1. Locate in an area where display can be read if necessary.
2. Secure to wall with 2 screws.
3. Route cable between display and Control Unit.

FIG 10

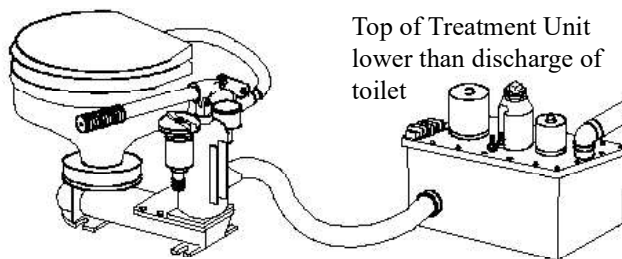

Treatment Unit within 6' [1.8 m]

FIG 11

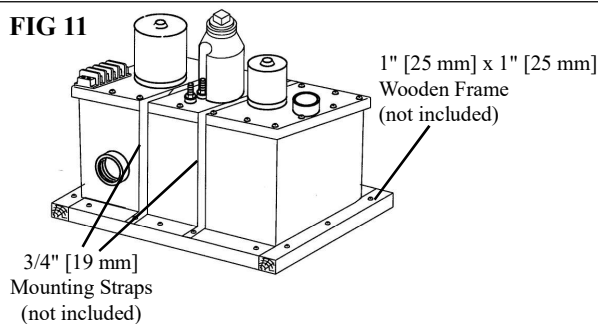
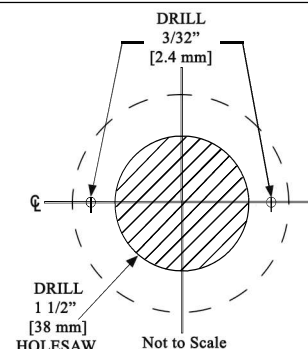

FIG 12

System Status Panel  
Apply a bead of nonpermanent sealant around rear edges of panel if located in shower area.



## PLUMBING

### WARNING: HAZARD OF FLOODING

- Installations at or below waterline, at greatest angle of heel, **MUST** have a **VENTED LOOP** installed between Treatment Unit and Seacock/Thru Hull Fitting. Install vented loops per manufacturer's instructions.
- Double clamp all below waterline hose connections.
- Do Not use metal fittings.

**NOTE:** Use PTFE tape or non-permanent thread sealing compound on threaded PVC fittings and connections. Avoid low areas in hose that would allow untreated waste to collect.

1. Connect discharge of toilet to one inlet port.
2. Insert plug or second toilet discharge into other inlet port.
3. Determine position and glue discharge elbow to top of tank using PVC cement after cleaning with PVC cleaner.
4. Connect discharge hose from elbow to thru hull fitting.

## WIRING

### WARNING: HAZARD OF SHOCK AND FIRE

- Make sure power is off before proceeding.
- Always use proper wire, wire connectors and fuse/circuit breaker. See Specification Chart.
- Do not connect other appliances to electroscan® circuit.
- Improper wiring can damage the Circuit Board and void warranty.
- Fuses must be replaced with the same type to maintain ignition protection.
- Secure wire properly.

### Treatment Unit

1. Determine proper wire size from wire chart on specifications page.
2. Run supply wire from source, Positive (POS) to Control Unit and Negative (NEG) to terminal on Treatment Unit.
3. Install terminal protector on positive connection.
4. Fuse or circuit breaker must be installed between source and Control Unit on positive wire.

**NOTE:** Future access to Control Unit is important. If unit is installed in an area where access will be difficult, wiring harness can be extended to a maximum of 10 feet by increasing the black (negative) and orange (mixer) wire gauge to 10 AWG [6.0 mm<sup>2</sup>].

### System Status Panel

1. Connect cable from System Status Panel to Panel 1 jack on Control Unit (FIG 14).
2. Install strain relief clamps along cable.
3. Follow same procedure for Panel 2 if dual installation

**NOTE:** Normal installations have one System Status Panel. Fig 14 depicts a dual control system installation (ESTDC).

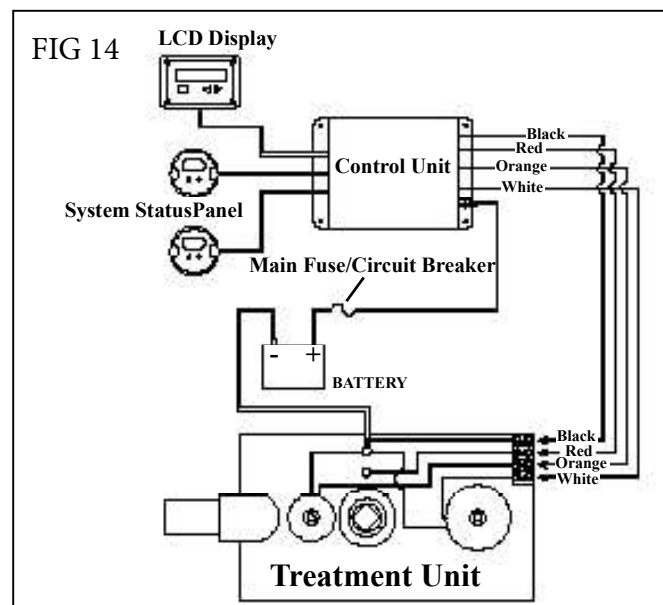
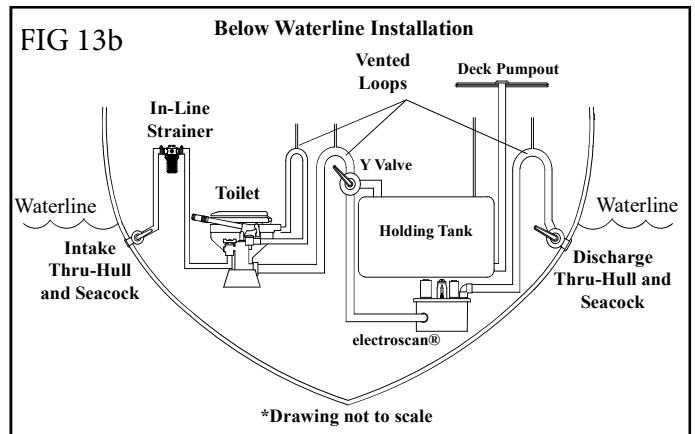
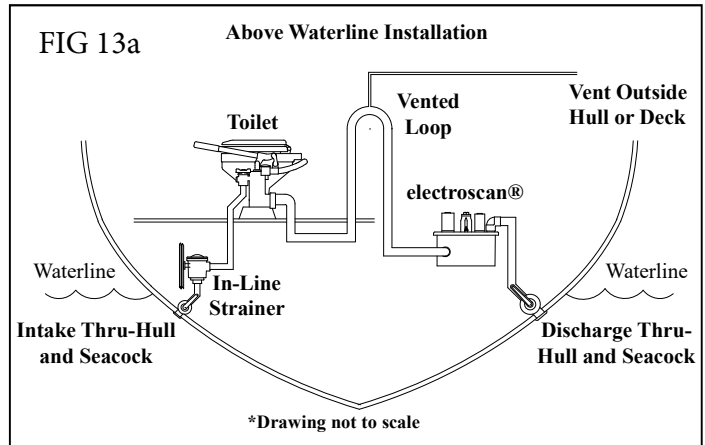
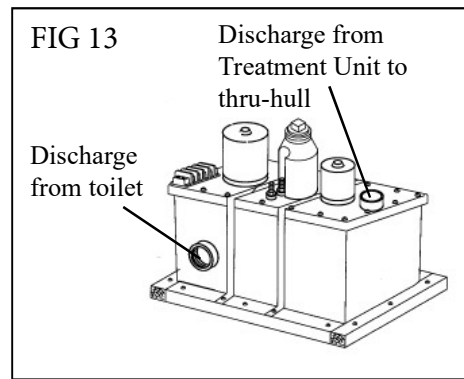

### LCD Display

1. Connect cable from LCD Display to display jack on the Control Unit (FIG 14)
2. Install strain relief clamps along cable.

### Wiring Salt Feed Pump: (Salt Feed Option)

Wire Salt Feed Pump as per FIG 15

### Single Button operation -

Both toilet and electroscan® are operated by one of the following options:

#### Option 1 (Recommended)

**Toilet Flush Control** - Flushing toilet will also activate treatment cycle.

- For **Momentary Flush Control (PRS)** wire per FIG 16.

**NOTE:** Solenoid/relay not needed when using PRS.

- For **Multifunction Flush Control (221600 White / 221600B Black)** wire per FIG 17.
- For **Smart Toilet Control (STC)** wire per FIG 18.
- For older model Atlantes contact Technical support or visit owner's manual page (discontinued product) at: [www.raritaneng.com](http://www.raritaneng.com)

### NOTES:

- Use only a solenoid/relay with an isolated coil, Raritan part number CDS\*\* (\*\*specify voltage).
- Do Not connect switches or any other components to the toilet/head 1 or 2 outputs or the CDS.
- Determine proper wire size for toilet as per toilet instruction manual.
- When toilet is flushed, electroscan® will activate.

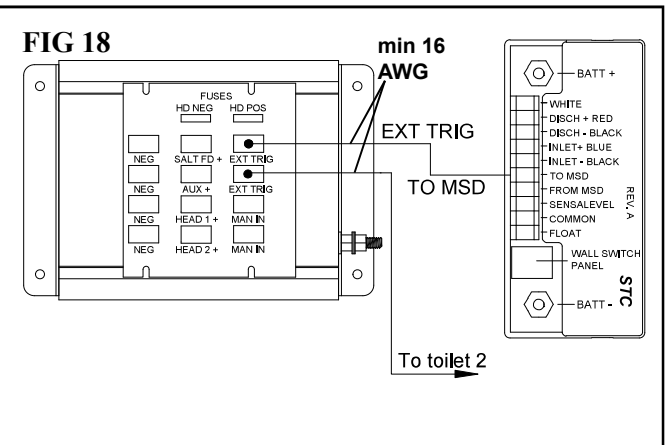
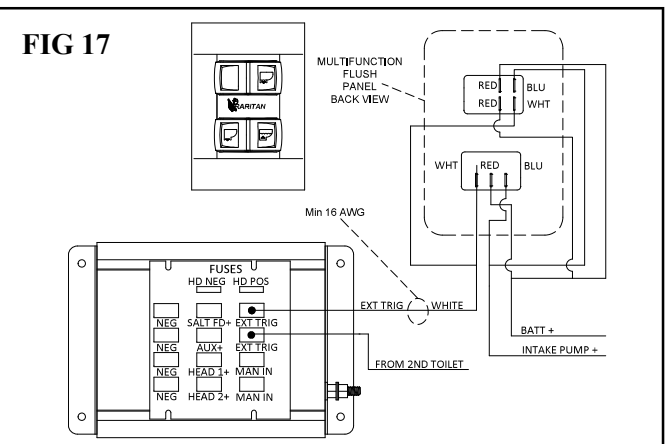
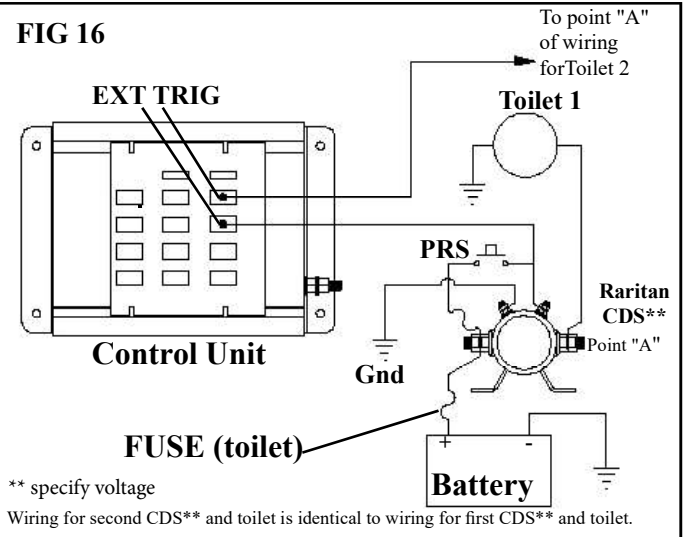
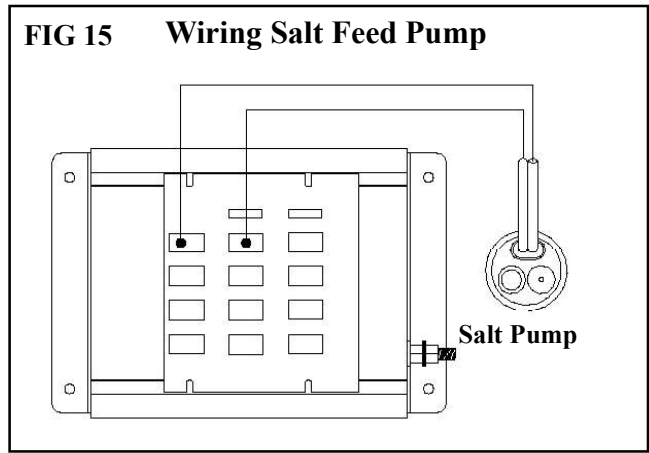

**Option 2 - Activation with System Status Panel:**

"Start/Stop" button activates both the toilet and treatment cycle.

- For other toilets wire per FIG 19. Raritan CDS\* (\*specify voltage) is required.

**NOTE:** Toilet flush time is factory pre-set at approximately 10 seconds and is adjustable.

- For Smart Toilet Control (STC) wire per FIG 20.

**NOTE:** Flush time adjustment for toilet on LCD display must be set to one second. See page 3.

- For older model Atlantes contact Technical support or visit owner's manual page (discontinued product) at: [www.raritaneng.com](http://www.raritaneng.com)

**NOTES:**

- Use only a solenoid/relay with an isolated coil Raritan part number CDS\*\* (\*\*specify voltage)
- Connect only the solenoid/relay (CDS\*\*) coil to toilet/head 1 or 2 quick connect. DO NOT connect toilet negative and positive directly to outputs.
- Do NOT connect switches or any other components to the toilet/head 1 or 2 outputs or the CDS\*\*.
- Determine proper wire size for toilet as per toilet instruction manual.
- When Start/Stop button is pressed, both toilet and electroscan® will activate. Toilet flush time is controlled by EST Control Unit and can be adjusted. Factory preset is for 10 seconds.

For STC, timing is controlled by the STC control.

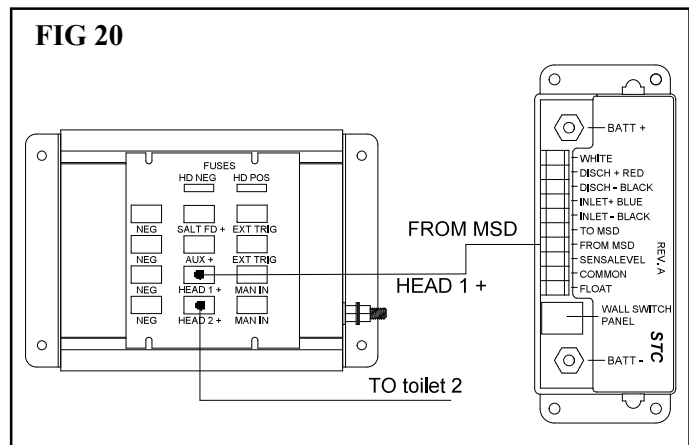
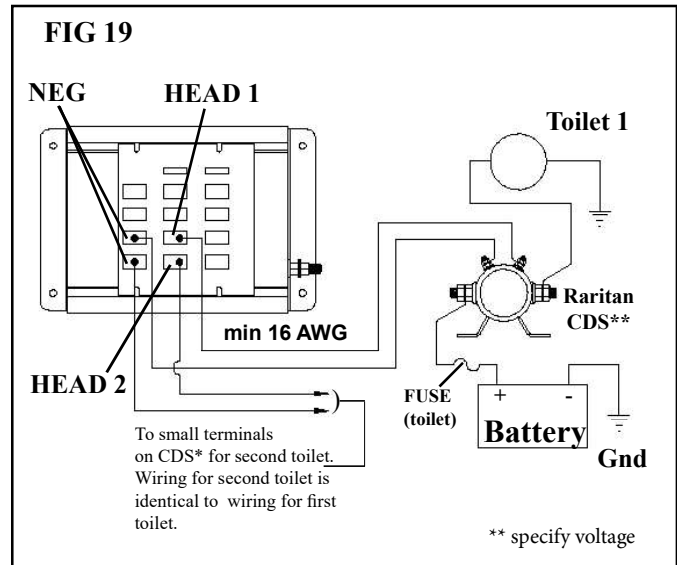

**How to remove microprocessor board**

**NOTE:** Static electricity will damage the board, use precaution and proper grounding to avoid static build-up while working with the microprocessor board.

- Turn off power.
- Open Control Unit cover.
- Microprocessor board can be pulled out without disconnecting any wires.
- Install replacement board.
- Use anti-static bag to pack board for return to dealer/factory.

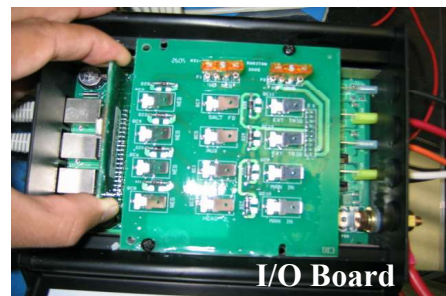

## NEW INSTALLATIONS

Prior to contacting Raritan for a problem with the electroscan® please have the following information available:

- 1) Model number, serial number and voltage of unit
- 2) Body of water if using raw water to flush toilet
- 3) Warnings or errors on the display



PROBLEM	POSSIBLE CAUSE	SOLUTION
Unit runs continuously as soon as power is turned on	<ol style="list-style-type: none"> <li>1. Reverse polarity , if unit is run for extended time seals on motor will be damaged.</li> <li>2. Display cable and System status cable switched, display is blank, LED on panel flashing.</li> <li>3. External trigger signal is on continuously.</li> </ol>	<ol style="list-style-type: none"> <li>1. Correct polarity.</li> <li>2. Turn power off, switch cables to correct sockets.</li> <li>3. Troubleshoot control source.</li> </ol>
Blank display	<ol style="list-style-type: none"> <li>1. Display was connected after power was turned on.</li> </ol>	<ol style="list-style-type: none"> <li>1. Hold MODE/RESET button until "Ready to Flush" is displayed.</li> </ol>
ERROR: LOW ELECTROD AMP	<ol style="list-style-type: none"> <li>1. Low salt causing electrode amps to be less than 7 amps.</li> </ol>	<ol style="list-style-type: none"> <li>1a. New installation with fresh water requires some salt in the treatment unit to start salt feed system.</li> <li>b. System requires salt source see page 2.</li> </ol>
ERROR: MIX MOTOR OVERLD	<ol style="list-style-type: none"> <li>1. Incorrect wiring between control and treatment unit</li> <li>2. DISCONNECT Display Cable on Control                             <ol style="list-style-type: none"> <li>a. Unit runs complete 2 minutes 30 seconds</li> <li>b. Unit faults in less than 15 seconds.</li> </ol> </li> </ol> <p>DISCONNECT MIX (Orange) motor wire on control - Run a cycle.</p> <ol style="list-style-type: none"> <li>a. Unit runs complete 2 minutes 30 seconds.</li> <li>b. Unit faults in less than 15 seconds.</li> </ol>	<ol style="list-style-type: none"> <li>1. Check/Correct wiring per schematic.</li> <li>2. With Display Cable disconnected:                             <ol style="list-style-type: none"> <li>a. Clean/Replace Display cable.</li> <li>b. Reconnect cable go to next step.</li> </ol> </li> </ol> <p>With MIX wire disconnected</p> <ol style="list-style-type: none"> <li>a. Repeat to verify - If confirmed check for jam in motor.</li> <li>b. Turn OFF Power - Inspect terminal connections on treatment unit for looseness/corrosion. Inspect control spade terminal. Inspect mixer fuse and fuse holder. Reseat Micro-processor (31-720). Replace control if problems persist.</li> </ol>
ERROR: MAC MOTOR OVERLD	<ol style="list-style-type: none"> <li>1. Incorrect wiring between control and treatment unit.</li> <li>2. DISCONNECT Display Cable on Control.                             <ol style="list-style-type: none"> <li>a. Unit runs complete 2 minutes 30 seconds.</li> <li>b. Unit faults in less than 15 seconds.</li> </ol> </li> </ol> <p>DISCONNECT MAC (White) motor wire on control - Run a cycle.</p> <ol style="list-style-type: none"> <li>a. Unit runs complete 2 minutes 30 seconds.</li> <li>b. Unit faults in less than 15 seconds.</li> </ol>	<ol style="list-style-type: none"> <li>1. Check/Correct wiring per schematic.</li> <li>2. With Display Cable disconnected:                             <ol style="list-style-type: none"> <li>a. Clean/Replace Display cable.</li> <li>b. Reconnect cable go to next step.</li> </ol> </li> </ol> <p>With MAC wire disconnected</p> <ol style="list-style-type: none"> <li>a. Repeat to verify - If confirmed check for jam in motor.</li> <li>b. Turn OFF Power - Inspect terminal connections on treatment unit for looseness/corrosion. Inspect control spade terminal. Inspect macerator fuse and fuse holder. Reseat Micro-processor (31-720). Replace control if problems persist.</li> </ol>
ERROR: ELECTROD OVERLD	<ol style="list-style-type: none"> <li>1. Too much salt in the treatment unit (electrode amps higher than 28 amps).</li> <li>2. DISCONNECT red electrode wire from black control unit and run a cycle.                             <ol style="list-style-type: none"> <li>a. If error changes to "low electrode amp" confirms too much salt.</li> <li>b. If error still occurs see 2b under solution.</li> </ol> </li> </ol>	<ol style="list-style-type: none"> <li>1. During new installation, if too much salt gets into the system, flush toilet without running EST. Salt feed tank must be lower or same level as treatment unit to avoid siphoning of salt tank.</li> </ol> <p>With ELECTRODE wire disconnected</p> <ol style="list-style-type: none"> <li>a. Flush toilet several times without activating system.</li> <li>b. Turn OFF Power - Inspect terminal connections on treatment unit for looseness/corrosion. Inspect control spade terminal. Inspect macerator fuse and fuse holder. Reseat Micro-processor (31-720). Replace control if problems persist.</li> </ol>
WARNING: AMPS < 14	<ol style="list-style-type: none"> <li>1. Low salt in the treatment unit during treatment cycle.</li> </ol>	<ol style="list-style-type: none"> <li>1a. Brackish water requires salt feed system.</li> <li>b. Check salt feed system, check connection to salt pump, check salt pump hose.</li> </ol>

## EXISTING INSTALLATIONS

# TROUBLESHOOTING

PROBLEM	POSSIBLE CAUSE	SOLUTION
"Start/Stop" doesn't activate system	<ol style="list-style-type: none"> <li>1. No Power</li> <li>2. Open or loose connection</li> <li>3. Display</li> <li>4. Inoperative Start/Stop</li> <li>5. Damage to cable</li> <li>6. Extreme low voltage</li> </ol>	<ol style="list-style-type: none"> <li>1. Check circuit breaker or main fuse and wiring.</li> <li>2. Check and clean wiring connections.</li> <li>3. Check display for errors.</li> <li>4. Check, replace as necessary.</li> <li>5. Check replace as necessary.</li> <li>6. Check voltage at control unit when Start/Stop button is pressed.</li> </ol>
ERROR: Electrode overlid	<ol style="list-style-type: none"> <li>1. Too much salt in the treatment unit (electrode amps higher than 28 amps)</li> <li>2. DISCONNECT red electrode wire from black control box and run a cycle                             <ol style="list-style-type: none"> <li>a. If error changes to "low electrode amp" confirms too much salt</li> <li>b. If error still occurs see 2b under solution</li> </ol> </li> </ol>	<ol style="list-style-type: none"> <li>1. During new installation if too much salt gets into the system, flush toilet without running EST. Salt feed tank must be lower or same level as treatment unit to avoid siphoning of salt tank.</li> <li>2. With ELECTRODE wire disconnected:                             <ol style="list-style-type: none"> <li>a. Flush toilet several times without activating system.</li> <li>b. Turn OFF Power - Inspect terminal connections on treatment unit for looseness/corrosion. Inspect control spade terminal. Inspect macerator fuse and fuse holder. Reseat Micro-processor (31-720). Replace control if problems persist.</li> </ol> </li> </ol>
POS/NEG Fuse Error	<ol style="list-style-type: none"> <li>1. POS fuse error - Toilet switch connected directly to control</li> <li>2. POS fuse blown</li> <li>3. NEG fuse blown</li> <li>4. NEG fuse error - Faulty relay or salt pump</li> </ol>	<ol style="list-style-type: none"> <li>1. Solenoid with isolated coil required (Raritan part CDS12 for 12V system).</li> <li>2. Replace fuse (refer to page 11, FIG 20).</li> <li>3. Replace fuse (refer to page 11, FIG 20).</li> <li>4. Check toilet relay, check salt feed pump and wiring.</li> </ol>
ERROR; MIX MOTOR OVERLD	<ol style="list-style-type: none"> <li>1. Incorrect wiring between control and treatment unit</li> <li>2. DISCONNECT Display Cable on Control                             <ol style="list-style-type: none"> <li>a. Unit runs complete 2 minutes 30 seconds</li> <li>b. Unit faults in less than 15 seconds</li> </ol> </li> </ol> <p>DISCONNECT MIX (Orange) motor wire on control</p> <p>- Run a cycle</p> <ol style="list-style-type: none"> <li>a. Unit runs complete 2 minutes 30 seconds</li> <li>b. Unit faults in less than 15 seconds</li> </ol>	<ol style="list-style-type: none"> <li>1. Check/Correct wiring per schematic.</li> <li>2. With Display Cable disconnected:                             <ol style="list-style-type: none"> <li>a. Clean/Replace Display cable.</li> <li>b. Reconnect cable go to next step.</li> </ol> </li> </ol> <p>With MIX wire disconnected:</p> <ol style="list-style-type: none"> <li>a. Repeat to verify - If confirmed check for jam in motor.</li> <li>b. Turn OFF Power - Inspect terminal connections on treatment unit for looseness/corrosion. Inspect control spade terminal. Inspect mixer fuse and fuse holder. Reseat Micro-processor (31-720). Replace control if problems persist.</li> </ol>
ERROR: MAC MOTOR OVERLD	<ol style="list-style-type: none"> <li>1. Incorrect wiring between control and treatment unit</li> <li>2. DISCONNECT Display Cable on Control                             <ol style="list-style-type: none"> <li>a. Unit runs complete 2 minutes 30 seconds</li> <li>b. Unit faults in less than 15 seconds</li> </ol> </li> </ol> <p>DISCONNECT MAC (White) motor wire on control</p> <p>- Run a cycle</p> <ol style="list-style-type: none"> <li>a. Unit runs complete 2 minutes 30 seconds</li> <li>b. Unit faults in less than 15 seconds</li> </ol>	<ol style="list-style-type: none"> <li>1. Check/Correct wiring per schematic.</li> <li>2. With Display Cable disconnected:                             <ol style="list-style-type: none"> <li>a. Clean/Replace Display cable.</li> <li>b. Reconnect cable go to next step.</li> </ol> </li> </ol> <p>With MAC wire disconnected:</p> <ol style="list-style-type: none"> <li>a. Repeat to verify - If confirmed check for jam in motor.</li> <li>b. Turn OFF Power - Inspect terminal connections on treatment unit for looseness/corrosion. Inspect control spade terminal. Inspect macerator fuse and fuse holder. Reseat Micro-processor (31-720). Replace control if problems persist.</li> </ol>
Low Amp Error or Warning on Display	<ol style="list-style-type: none"> <li>1. Low Salt</li> <li>2. Dirty Electrode Pack</li> <li>3. Worn electrode</li> </ol>	<ol style="list-style-type: none"> <li>1a. Add 2 gallons of water with 8 oz. (by weight) of salt to system and run a cycle.</li> <li>1b. Check salt feed system if installed.</li> <li>2. Clean the electrode pack following instructions in maintenance, see page 5.</li> <li>3. If steps 1 or 2 do not work, replace electrode pack.</li> </ol>
Low Voltage Error or Warning	<ol style="list-style-type: none"> <li>1. Low Voltage</li> <li>2. Drop in line voltage</li> <li>3. Other Equipment on same circuit</li> <li>4. Open or loose connections</li> </ol>	<ol style="list-style-type: none"> <li>1. Check battery condition, charge or replace as necessary.</li> <li>2. Check voltage between positive at control unit and negative at control unit or top of treatment unit while unit is running.</li> <li>3. Isolate Electroscan on it's own circuit.</li> <li>4. Check and clean wire connections.</li> </ol>
Sewage Odor	<ol style="list-style-type: none"> <li>1. Odor permeating through hose or connections</li> <li>2. Treatment unit leaking</li> <li>3. Electrode not working properly</li> <li>4. Electroscan not activated with each flush</li> <li>5. Treatment unit not being stored properly</li> </ol>	<ol style="list-style-type: none"> <li>1. Rub warm, damp rag on hose. If odor transfers to rag replace hose Raritan Sanitation Hose #SFH.</li> <li>2. Inspect hose from toilet to treatment unit and look for leaks on top of treatment unit.</li> <li>3. Check reading on LCD display for error or warning.</li> <li>4. System must be activated with each flush.</li> <li>5. See storage under maintenance.</li> </ol>
Water around motor on or lid	Motor shaft seal leak	Order repair kit ESTRK, includes all parts needed to repair seal leak.

# ELECTROSCAN® EXPLODED PARTS VIEW

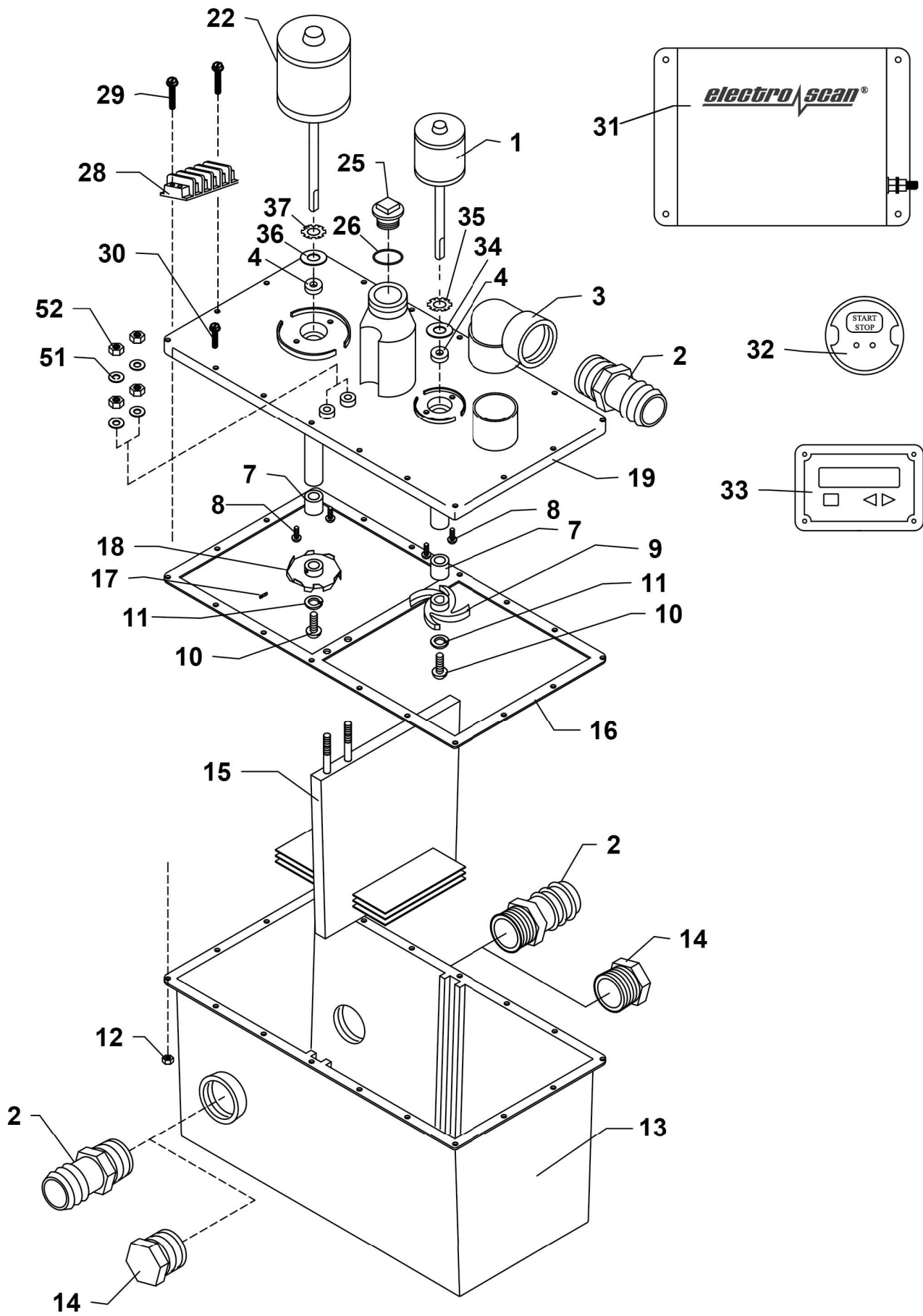

# ELECTROSCAN® EXPLODED PARTS LIST

<b>Item</b>	<b>Part #</b>	<b>Description</b>
1	32-102AW	Mixer Motor 2 1/2" Dia. 12 VDC
1	33-102AW	Mixer Motor 2 1/2" Dia. 24 VDC
		(1) includes shaft seals and bushing for mixer motor)
2	31-121	Hose Fitting (2)
3	31-120	Discharge Elbow 90°
4	31-102	Motor Shaft Seal
7	31-103	Motor Shaft Bushing (2)
8	F351	Motor Hold down Bolt, 10-32x1", S/S (4)
9	31-109	Mixer Impeller
10	31-110-1	Impeller Bolt, 12-24 x 5/8", S/S (2)
11	31-110-2	Impeller Lock Washer, #12, S/S (2)
12	31-114	Lock Nut, 10-32 (18)
13	31-115PS	Treatment Unit
14	31-122	Intake Plug
15	32-5000	Electrode Pack 12 VDC
15	33-5000	Electrode Pack 24 VDC
16	31-112	Cover Gasket
17	31-108	Macerator Set Screw
18	31-107	Macerator Impeller
19	31-101W	Treatment Cover
22	33-101AW	Macerator Motor for 12 and 24 VDC unit
25	31-104CW	Crossover Plug with O-ring (Includes 26)
26	31-105	O-Ring
28	ETB2	Terminal Block
29	31-113-2	Terminal Block Bolt (2)
30	31-134	Cover Hold down Bolt, 10-32 x 1" (18)
34	31-102-3	Mixer Seal Washer
35	31-102-4	Mixer Retaining Ring
36	31-102-1	Macerator Seal Washer
37	31-102-2	Macerator Retaining Ring
51	M31	#14 Brass Flat Washer (4)
52	M30	1/4"-20 Brass Nut (4)

## CONTROLS

31	32-700	Control Unit 12 VDC
31	33-700	Control Unit 24 VDC
32	31-705	System Status Panel
33	31-702	LCD Display
31-618		Cable for LCD and System Status Panel 15' (not shown)
WAES01T		Wire Harness (not shown)

## PARTS BAG (packed with each new control unit)

31-111		Cable Clamp 1/2" x 1/2"
31-717		Insulating Bushing (2)
ETP1		Terminal Protector Red
F110		Screw 6 x 1/2" Phil Pad HD (4) to mount Display and Start/Stop button

## ESTRK

### EST/PST Repair Kit includes following:

31-102		Motor Shaft Seal (2)
31-102-1		Macerator Seal Washer
31-102-2		Macerator Retaining Ring
31-102-3		Mixer Seal Washer
31-102-4		Mixer Retaining Ring
31-103		Motor Shaft Bushing (2)
31-105		O-Ring
F351		10-32x7/8" w/ O-ring (4)
31-112		Cover Gasket
31-113-2		Terminal Block Bolt (4)
31-114		Lock Nut, 10-32 (4)
SL1CC		Super Lube

32-7000	12 VDC Treatment Unit - No Control Unit, System Status Panel or LCD Display
33-7000	24 VDC Treatment Unit - No Control Unit, System Status Panel or LCD Display

31-3001	Salt Feed Tank Complete, 2 gallon (not shown)
32-3006	Salt Feed Brine Tank Assembly, with Float Switch and Pump, 12 VDC (not shown)
33-3006	Salt Feed Brine Tank Assembly, with Float Switch and Pump, 24 VDC (not shown)

( ) Indicates total pieces required

## OTHER INSTALLATION OPTIONS FOR THE electroscan® SYSTEM :

The electroscan® has other installation options including:

- 1) Connection to the Sealand VacuFlush®

The above option is covered by a Technical Bulletin available from Raritan by calling: 856-825-4900.

Request document # L286 0107

®Vacuflush is a registered trademark of Sealand Technology, Inc.

---

### LIMITED WARRANTY

Raritan Engineering Company warrants to the original purchaser that this product is free of defects in materials or workmanship for a period of one year from the product's date of purchase. Should this product prove defective by reason of improper workmanship and/or materials within the warranty period, Raritan shall, at its sole option, repair or replace the product.

1. TO OBTAIN WARRANTY SERVICE, Consumer must deliver the product prepaid, together with a detailed description of the problem, to Raritan at 530 Orange St., Millville, N.J. 08332. When requesting warranty service, purchaser must present a sales slip or other document which establishes proof of purchase. THE RETURN OF THE OWNER REGISTRATION CARD IS NOT A CONDITION PRECEDENT OF WARRANTY COVERAGE. However, please complete and return the owner Registration Card so that Raritan can contact you should a question of safety arise which could affect you.
2. THIS WARRANTY DOES NOT COVER defects caused by modifications, alterations, repairs or service of this product by anyone other than Raritan; defects in materials or workmanship supplied by others in the process of installation of this product; defects caused by installation of this product other than in accordance with the manufacturer's recommended installation instructions or standard industry procedures; physical abuse to, or misuse of, this product. This warranty also does not cover damages to equipment caused by fire, flood, external water, excessive corrosion or Act of God.
3. ANY EXPRESS WARRANTY NOT PROVIDED HEREIN, AND ANY REMEDY FOR BREACH OF CONTRACT WHICH BUT FOR THIS PROVISION MIGHT ARISE BY IMPLICATION OR OPERATION OF LAW, IS HEREBY EXCLUDED AND DISCLAIMED. ALL IMPLIED WARRANTIES SUCH AS THOSE OF MERCHANTABILITY AND OF FITNESS FOR A PARTICULAR PURPOSE, IF APPLICABLE, AS WELL AS ANY IMPLIED WARRANTIES WHICH MIGHT ARISE BY IMPLICATION OF LAW, ARE EXPRESSLY LIMITED TO A TERM OF ONE YEAR. SOME STATES DO NOT ALLOW LIMITATIONS ON HOW LONG A LIMITED WARRANTY LASTS, SO THE ABOVE LIMITATION MAY NOT APPLY TO YOU.
4. UNDER NO CIRCUMSTANCES SHALL RARITAN BE LIABLE TO PURCHASER OR ANY OTHER PERSONS FOR ANY SPECIAL OR CONSEQUENTIAL DAMAGES, WHETHER ARISING OUT OF BREACH OF WARRANTY, BREACH OF CONTRACT, OR OTHERWISE. SOME STATES DO NOT ALLOW THE EXCLUSION OR LIMITATION OF INCIDENTAL OR CONSEQUENTIAL DAMAGES, SO THE ABOVE LIMITATION OR EXCLUSION MAY NOT APPLY TO YOU.
5. No other person or entity is authorized to make any express warranty, promise or affirmation of fact or to assume any other liability on behalf of Raritan in connection with its products except as specifically set forth in this warranty.
6. This warranty gives you specific legal rights, and you may also have other rights which vary from state to state.



530 Orange Street, Millville, NJ 08332 USA  
Telephone: 856-825-4900 FAX: 856-825-4409  
www.raritaneng.com

# Thank you for purchasing a Raritan electroscan<sup>®</sup>

Model and Serial # :  
Please have this available if support is needed.

SCAN for  
Owners Manual



L340

SCAN for  
Warranty Form



If you prefer a printed version of the Owners Materials:  
Email: [info@raritaneng.com](mailto:info@raritaneng.com)

Questions on installation?  
Email: [techsupport@raritaneng.com](mailto:techsupport@raritaneng.com)



## Do not return this product to store.

**PLEASE RETAIN FOR YOUR RECORDS**