

ATLANTES FREEDOM™ TOILET VORTEX-VAC™

Installation and Maintenance Instructions MODEL AVL (ELONGATED BOWL)

THE FOLLOWING ARE CAUTIONARY STATEMENTS THAT MUST BE READ AND FOLLOWED DURING BOTH INSTALLATION AND OPERATION.

WARNING: *Raritan Engineering Company, Inc. recommends that a qualified person or electrician install this product. Equipment damage, injury to personnel or death could result from improper installation. Raritan Engineering Company, Inc. accepts no responsibility or liability for damage to equipment, injury or death to personnel that may result from improper installation or operation of this product.*



WARNING: HAZARD OF SHOCK OR FIRE

Always use recommended fuse, circuit breaker and wire size.



Motors used with this product are "Ignition Protected". They are not however, explosion-proof.

DO NOT run continuously for more than 30 seconds.

Description:

Our Atlantes Freedom Vortex-Vac elongated toilet is available in white or almond, 12V, 24V DC, and 120V/240V AC. Fresh water model utilizes onboard pressurized fresh water. The raw water model utilizes a remote intake pump to pump raw water to the bowl. The Sea Fresh model can switch between fresh and raw water source.

Flush control options available:

1. **Flush Handle Control:** Provides momentary operation of flush water and discharge. Available in momentary or timed.
2. **Smart Toilet Control:** Provides timed operation and independent control of flush water and discharge with handle or wall switch.
3. **Multifunction Flush Panel:** Provides momentary operation and independent momentary control of flush water and discharge.
4. **Wireless Remote Bluetooth Control:** Operate your Atlantes smart toilet control panel up to 50 ft. away from the toilet. Eliminates the need to route wires through bulkheads and cabinetry.

Model and Serial#:

Please have this available if support is needed.

Pressurized Fresh Water Model



Raw Water Model (Remote Pump)



SCAN for
Warranty Form



IMPORTANT SAFETY INSTRUCTIONS:

WARNING: HAZARD OF FLOODING - Always shut off seacock(s) before leaving the boat unattended.



Double clamp all below waterline hose fittings and check frequently for integrity.

WARNING:

Young children should NOT be left unsupervised around toilet. Serious injury or death could occur. Children can drown in water retained in the bowl. Seat and lid could close and strike child.

Always replace circuit breaker and fuses with same rating. Use Raritan parts to maintain ignition protection requirements.

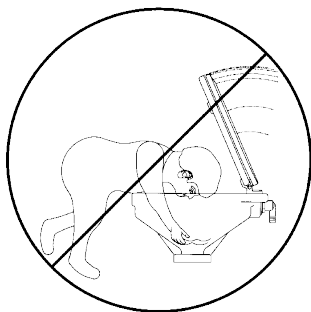

Cleaning Instructions

IMPORTANT: Do not use cleaners that contain ammonia, ethyl acetate, phosphoric acid or concentrated chlorine bleach. Do not allow acids, such as vinegar, and other cleaners to sit for extended periods of time in the toilet. These may cause damage to the toilet. Do not use abrasive cleaners or cleaning pads. Flushing fresh water through toilet when leaving for extended periods is recommended.

Using C.P. a bio-enzymatic toilet bowl cleaner, (available from Raritan Engineering Part# 1PCP32), will keep the bowl clean and fresh smelling.

Toilets mounted at or below the waterline must have a vented loop installed in the discharge line. See vented loop manufactures recommendation for minimal height above water line. The top of the vented loop must be a minimum of 4" (10cm) above the waterline at the boats greatest angle of heel (see vented loop manufacturer's instructions).

Raw water models must also have a vented loop installed between the intake pump and the toilet bowl.

Double clamp all below waterline connections.

Recommended Visual Inspection

- ✓ No leaks at toilet and hose connections
- ✓ Hose clamps
- ✓ Condition of hoses
- ✓ Seacocks
- ✓ Condition of wires and connections
- ✓ In-Line Strainer (if you have one)

- No special toilet paper is required.
- Water should appear in the bowl within ten seconds. If not, see troubleshooting section.
- Hard objects or stringy substances (paper towels, feminine hygiene products, cigarette filters, etc.) must not be thrown into the toilet as they will cause damage.
- Always shut off seacock(s) before leaving the boat unattended.

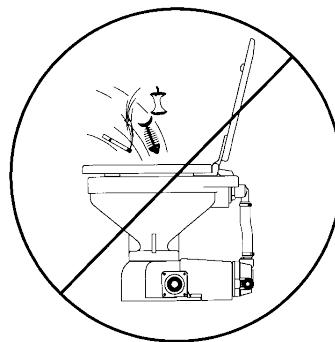

Toilet Operation:

Please see instructions included with control to see how to operate your unit.

SYSTEM START-UP

1. Open seacock(s).

NOTE: Pressurized fresh water models; open water source valve.

2. Turn on power to toilet.
3. Flush toilet per Operation Instructions.
4. Check for leaks.

IMPORTANT: If toilet does not flush properly or if water does not enter the bowl within 10 seconds, refer to Troubleshooting.

WINTERIZING

- Improper winter lay up is a major cause of marine toilet failure.
- Use only nontoxic antifreeze.
- Flush toilet several times to clear waste from system.
- Dispose of all antifreeze in accordance with local and federal regulations.
- Winterize holding tanks, plumbing, treatment systems (MSD's), etc. independently following manufacturer's instructions.

Winterizing Pressurized Fresh Water Models

Parts Required

- 1" (25 mm.) or 1 1/2" (38 mm.) I.D. discharge hose, approximately 3 feet (1 m.) long
- Two buckets
- Nontoxic antifreeze approximately 1 quart (1 liter)

Steps

1. Close discharge seacock (if one exists).
2. Shut off intake water at source.
3. Turn off power to unit.
4. Disconnect and drain intake and discharge hose.
5. Disconnect intake hoses from toilet and place in one of the buckets.
6. Connect short hose to toilet's discharge and place in other bucket.
7. Pour antifreeze in bowl.
8. Turn on power to unit and flush until antifreeze is removed from the bowl and water is drained from the solenoid and hose.
9. Disconnect power to toilet.
10. Reconnect intake hoses to water solenoid.

Winterizing Intake Pump Models

Parts Required

- 3/4" (19 mm.) I.D. intake hose approximately 3 feet (1 m.) long.
- 1" (25 mm.) or 1 1/2" (38 mm.) I.D. discharge hose approximately 3 feet (1 m.) long.
- Two buckets
- Nontoxic antifreeze approximately 1 quart (1 liter)

Steps

1. Close the intake and discharge seacocks.
2. Turn off power to unit.
3. Disconnect and drain pump suction hose and toilet discharge hose .
4. Connect short hoses to pump's suction intake and to toilet discharge.
5. Place one empty bucket under hose connected to toilet's discharge.
6. Pour nontoxic antifreeze in other bucket.
7. Place hose connected to intake pump into bucket with antifreeze.
8. Turn on power to unit and flush toilet until antifreeze begins to be discharged from toilet.
9. Disconnect power from toilet.

RECOMMISSIONING

1. Using the buckets, hoses and approximately one gallon (3.8 liters) of clean fresh water, flush antifreeze out of the toilet (see Winterizing). Dispose of antifreeze in accordance with local and federal regulations.
2. Reconnect the intake and discharge hoses and open both seacocks and water source valve.
3. Check all connections for leaks with several test flushes.

Plumbing

Maximum suction of Intake pump (Maximum height above waterline)	4 Ft. (1.2m) from Intake Pump.
Maximum height of discharge vented loop	10 Ft. (3 m) from base of toilet.
Pressurized water source minimum requirements	Minimum flow rate 3 gallons (11.5 liters)per minutes, Minimum Pressure 5 PSI(34.5 Kpa)

CONVERSIONS								
Wire - AWG to mm ²								
AWG	16	14	12	10	8	6	4	2
mm²	1.5	2.5	4.0	6.0	10.0	16.0	25.0	35.0
Feet to Meters								
Feet	10	15	20	25	30	40	50	
Meter	3.1	4.6	6.1	7.6	9.2	12.2	15.2	

NOTES: for Wiring

1.	Distances are from source to unit and back to source.
2.	Distance from power source to remote intake pump MUST be included when determining total distance. Same wire size MUST be used for lower base and remote intake pump.
3.	Recommended conductor wire minimum AWG (mm ²) for 3% voltage drop.
4.	Recommended conductor sizes are based on 105°C rated insulation. Refer to ABYC Standards for other insulation ratings.
5.	For 120/240 VAC units use 12VDC specifications from transformer to unit.

Recommended Wire and Fuse/Circuit Breaker Sizes

Raw Water Model (sizes based on both remote intake and discharge pumps amps added together)

Units Voltage	Circuit Breaker/ Fuse size	Toilet Discharge Pump amp draw	Remote Intake Pump amp draw	10 feet	15 feet	20 feet	30 feet	40 feet	50 feet
12 VDC	30	18	10	10 AWG	8 AWG	6 AWG	4 AWG	4 AWG	2 AWG
24 VDC	20	10	5	16 AWG	14 AWG	12 AWG	10 AWG	10 AWG	8 AWG

Pressurized Fresh Water Model

Units Voltage	Circuit Breaker/ Fuse size	Amp draw	10 feet	15 feet	20 feet	30 feet	40 feet	50 feet
12 VDC	25	18	10 AWG	10 AWG	8 AWG	6 AWG	6 AWG	4 AWG
24 VDC	15	10	16 AWG	16 AWG	14 AWG	12 AWG	10 AWG	10 AWG

Remote Intake Pump Only (Raw and Sea Fresh Models)

Units Voltage	Circuit Breaker/ Fuse size	Amp Draw	10 feet	15 feet	20 feet	30 feet	40 feet	50 feet
12 VDC	15	10	14 AWG	12 AWG	10 AWG	10 AWG	8 AWG	6 AWG
24 VDC	10	5	16 AWG	16 AWG	16 AWG	16 AWG	14 AWG	12 AWG

Hose Sizes

Inlet: 1/2" (13 mm.) for fresh water model
3/4" (19 mm.) for raw water model

Discharge: 1" (25 mm.) or 1 1/2" (38 mm.)

Water Consumption:

Water Saver : 2 pint*
Regular Flush: 2 quarts
* requires timing adjustment

Parts included with all models

1. Toilet bowl assembly
2. Mounting hardware
3. Seat
4. One of the following flush controls:
 - a. Flush handle control
 - b. Multifunction Momentary Control
 - c. Smart Toilet Control
5. User guides and Installation guides with labels

Additional Parts Required

- Two stainless steel mounting bolts or lag screws (minimum 1/4" [6mm] and washers)
- 1" (25 mm.) or 1 1/2" (38 mm.) I.D. discharge hose
- 3/4" (19 mm.) for raw water models or 1/2" (13mm) for fresh water models, reinforced intake hose.
- Hose clamps (two for each connection below waterline)
- Wire
- Terminals
- Fuse/circuit breaker

Additional Parts included with raw water

model:

1. Remote pump assy.

Atlantes discharge Maximum recommended 1" or 1 1/2" PVC hose length

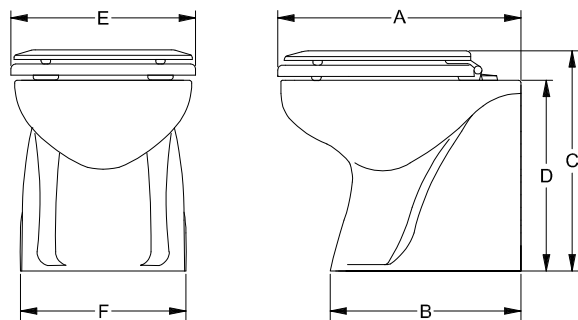
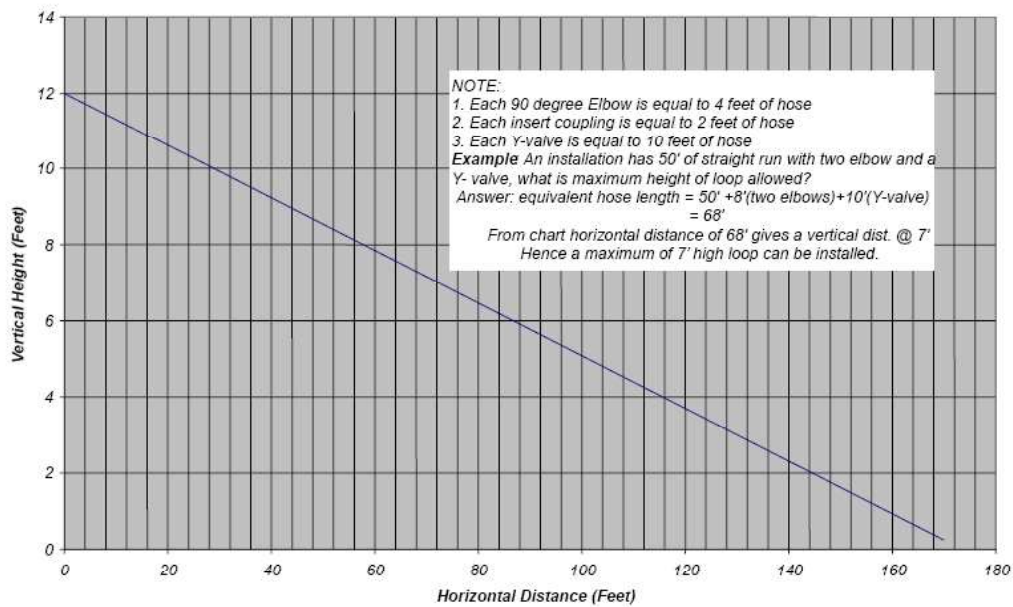

SIZE Inches (mm)

Bowl	A	B	C	D	E	F
Elongated	21 1/2 (545)	18 1/4 (455)	17 (432)	15 (381)	14 1/8 (359)	14 (355)

MOUNTING

Mounting surface must be flat and solid.

1. Place toilet where it will be located.
Make sure there is room to route hoses.
Make sure seat will open properly.
2. Using a pencil, mark location of bowl mounting holes (FIG 2).
3. A. If hoses will be routed through floor, trace one side of toilet on floor.
B. If hoses will be routed through wall, trace one side of toilet on wall.
4. Remove toilet and mark location for hoses and wiring on deck or wall.
5. Cut necessary holes for hoses and wiring.
6. Drill holes for toilet mounting bolts/screws.

NOTE: Use 1/4" (6 mm) size bolts/screws. To select proper screw or bolt length, measure thickness of deck plus 1 1/8" (29 mm).

TIP: Do not install until all wiring and plumbing is done. Secure toilet to floor after installation is complete.

CAUTION: Do Not over tighten mounting bolts. Damage to the toilet bowl may occur. Tighten both mounting bolts evenly and slowly.

Mounting toilet

1. Install mounting bushings, bolts.
2. Tighten bolts being careful to not over-tighten (Do not exceed 30 inch lb. when tightening)
3. Install caps over mounting bolts.

Mounting Remote Pump

1. Remote pump uses 3/4" (19mm) ID hose for connection.
2. Locate remote pump between thru hull fitting and toilet bowl.
3. Locate in an area away from berth to keep noise level down.
4. Use Inline Strainer part 163000 (recommended) to avoid clogs.
5. Secure remote pump to the floor using four bolts through the pump base (FIG 4).

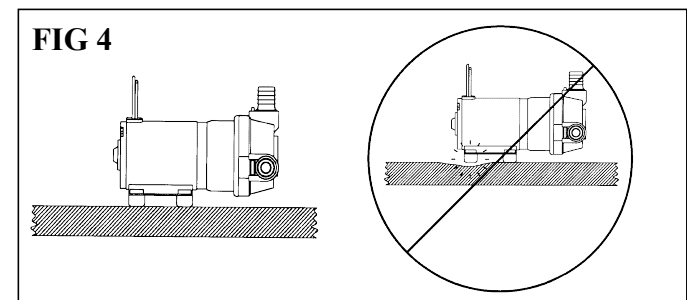
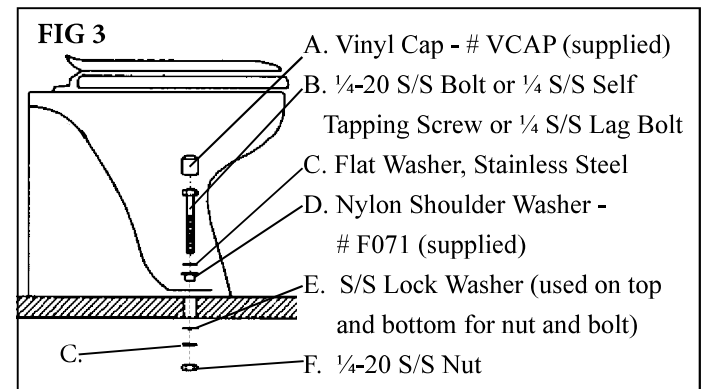
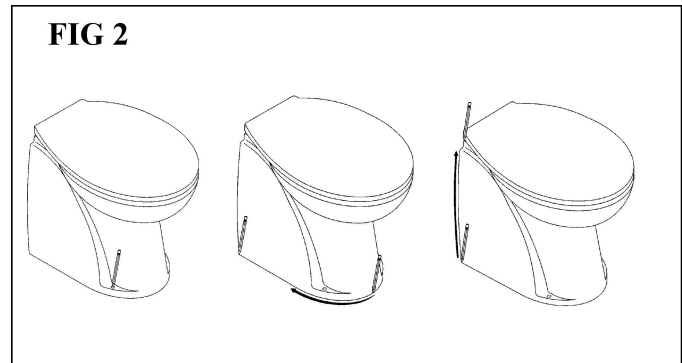
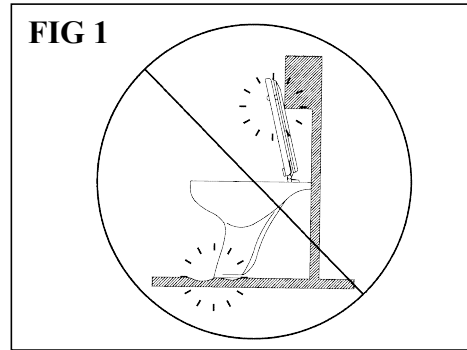

WIRING

FOLLOW THE INSTRUCTIONS INCLUDED WITH CONTROL

Raritan Sanitation Hose is recommended
SaniFlex Hose Part numbers:

SFH 1 1/2 inch

SFH1 1 inch

PLUMBING

WARNING: HAZARD OF FLOODING

Toilets mounted at or below the waterline, at greatest angle of heel, and connected to a Seacock/Thru Hull Fitting(s) **MUST** have **VENTED LOOPS** installed in toilet discharge plumbing and between raw water intake pump and toilet bowl.

Install vented loops per manufacturer's instructions. Double clamp all below-waterline connections.

IMPORTANT

- Fittings and 90° bends should be kept to a minimum.
- In-Line Strainer may be installed on raw water models to prevent clogs.
- Discharging untreated sewage is forbidden in all U. S. waters within the three-mile limit.
- Thru-hull fittings and seacocks must be installed where they are easily accessible.
- Use only quality reinforced hoses such as Raritan SANIFLEX HOSE.
- Secure all hoses properly.

Residual Water in the Bowl

The Atlantes Internal Discharge Hose is equipped with an integral vent to maintain water, up to 4" inches, in the bowl when the plumbing lines are routed downward (See FIG 7a and FIG 7b). A flush control that adds water at the end of the flush cycle, such as our Smart Toilet Control (STC), is required for optimal water retention. The toilet must be highest connection in the discharge plumbing when using this vent to retain water in the bowl. IF THE DISCHARGE PLUMBING IS ROUTED UPWARD (such as below water line installations), **DO NOT REMOVE THE VENT CAP** (FIG 7b).

To enable Integral Vent, remove Vent Cap (FIG 8), connect 1/4 hose and connect hose to a deck vent fitting (Reference FIG 6). Hose and deck fitting not included.

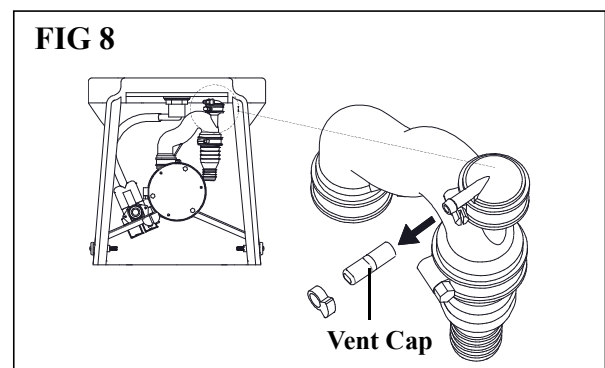
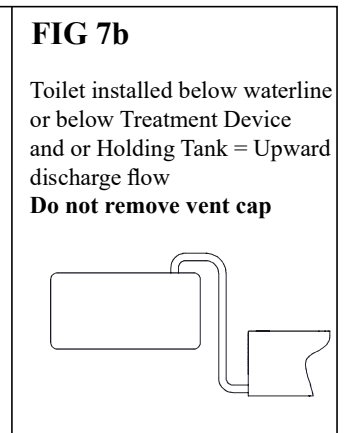
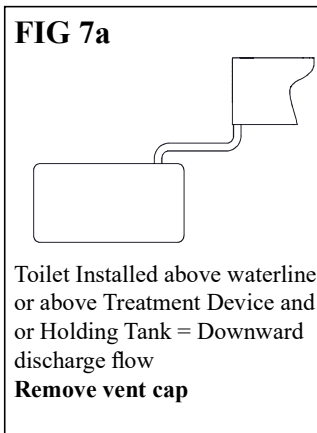
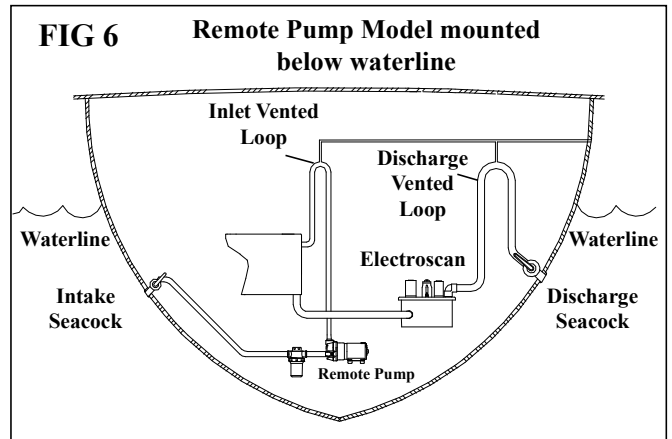
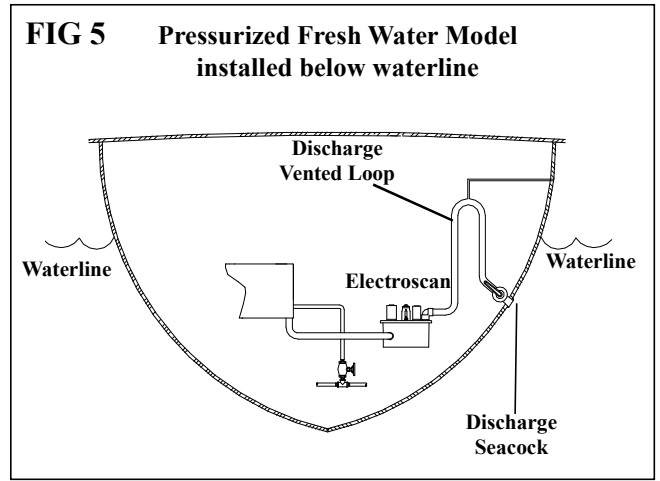

Discharge Lines

Raritan Sanitation Hose is recommended. Use part number SFH for 1 1/2" hose or SFH1 for 1" hose

1. Connect sanitation hose to discharge fitting on toilet.

NOTE: Discharge fitting is designed for 1" or 1 1/2" hose. 1 1/2" hose is secured at top of fitting and 1" is secured at the bottom. It is not necessary to remove the 1" barb if using 1 1/2" hose. Use the fitting as is.

2. Run hose to appropriate device (e.g.: treatment system, holding tank, etc.).

NOTE: If installation requires routing through the backwall rather than the floor, 90 degree kits are available:

Use part# 221147 for 1 1/2" hose or 221148 for 1" hose.

Intake Lines

Pressurized Fresh Water Models

1. Connect 1/2 (13 mm) I.D. hose to pressurized fresh water supply.
2. Install a shut off valve in intake line before water solenoid valve.
3. Connect hose from shut off valve to inlet port of water solenoid valve at the toilet.

NOTE: To avoid malfunction of water solenoid due to debris in water, installation of Fresh Water Strainer (190601) is recommended.

Connecting Remote Pump

Remote pump fittings are interchangeable to allow more flexibility during installation. Inlet ports are located on either side of intake pump. Outlet port (to toilet bowl) is at top of intake pump (FIG 10).

NOTE: To avoid poor pump performance installation of strainer (163000) is recommended

1. Slide fitting clips to open position (FIG 10).
2. Select inlet port to be used.
3. Install appropriate fittings into inlet and outlet ports.

NOTE: The 90° fitting can be rotated 360°.

4. Install the plug fitting into unused inlet port.

IMPORTANT: DO NOT install plug fitting into outlet port! Damage to pump will occur!

5. Slide fitting clips back to closed position (FIG 10).
6. Connect hose from seacock to inlet port of intake pump. If used, strainer is in-line. Use hose clamp provided.

IMPORTANT: Double clamp all below waterline hose connections!

7. Connect hose from outlet port of intake pump to bowl elbow located on back of toilet bowl.

Connecting hoses and wiring to toilet

1. Route wire from control per control instruction.
2. Install seat. Install discharge hose support strap between seat nut and the bowl. See FIG 11
3. Install toilet in place, connect hoses and wire plugs.

CAUTION: To avoid kinking to not pull on discharge hose, be certain there is no pressure on the discharge line.

FIG 9

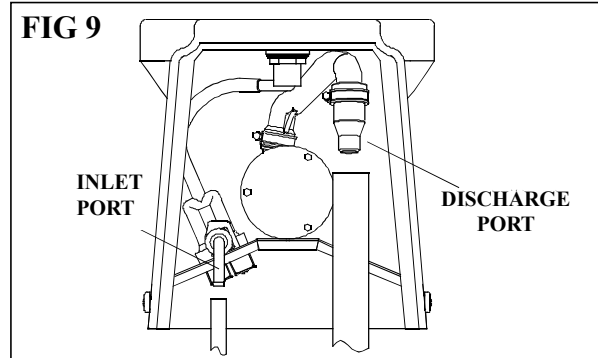

FIG 10

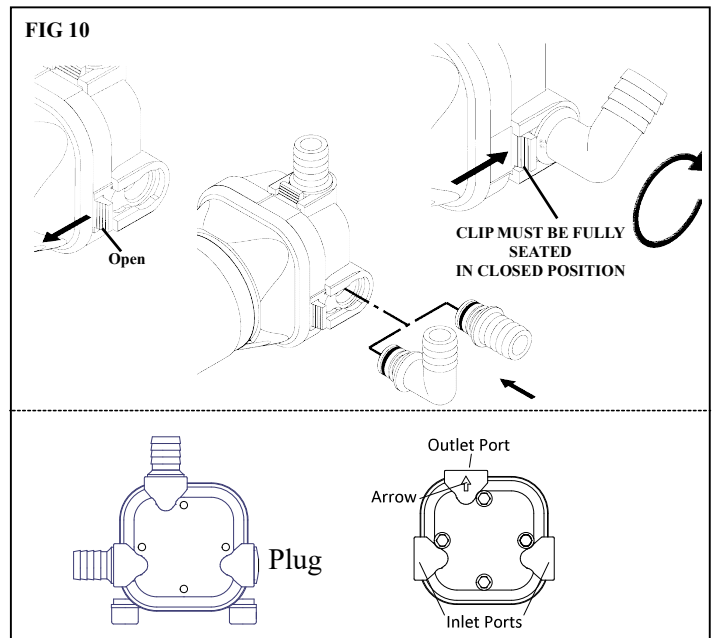
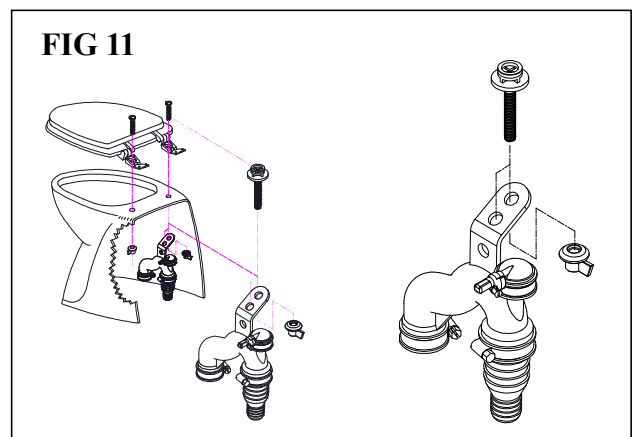

FIG 11



TROUBLESHOOTING

WARNING: HAZARD OF ELECTRIC SHOCK - Before beginning any work on the toilet, be sure that all power to the unit has been turned off.

WARNING: HAZARD OF FLOODING - Make sure seacocks are in the CLOSED or OFF position before working on toilet.

NOTE: The following information reflects the most probable causes and solutions to problems although not every possible cause and solution is provided.

Any questions regarding servicing or operation of the Marine Elegance should be directed to our Technical Support Department in Millville, NJ. Please have model and serial number available before calling.

PROBLEM	POSSIBLE CAUSE	SOLUTION
1. Poor pumpout, especially solids.	1A. Clogged discharge line. 1B. Plumbing restrictions, bends and ells. 1C. Clogged vents. 1D. Mineral buildup in hoses and fittings. 1E. Low voltage.	1A. Be sure discharge seacock is open. Clear line, remove clog. 1B. Replumb to eliminate bends and ells. 1C. Clean holding tank vent and vented loop vents 1D. Clean or replace affected parts. Replace hose if needed. 1E. Check voltage at toilet while toilet is running . If less than nominal voltage of toilet (12 or 24), check condition of batteries and wire sizes. Check terminals and wire connections for corrosion (heat at terminals and junctions indicates a bad or corroded connection).
2. Poor water flow, especially at front of bowl (or no water flow).	2A. Toilet not level. 2B. Restriction in intake line. 2C. Pump sucking air. 2D. Low voltage. 2E. Clogged strainer.	2A. Raise rear of toilet; check with level. 2B. Be sure seacock is open. Clear line-remove clog. 2C. Check all connections from intake thru-hull to intake pump to be sure no air leaks are present. 2D. See 1E, above. 2E. Remove or Clear debris from strainer.
3. Foul odors from toilet area.	3A. "Marine life" lodged in rim of bowl. 3B. Permeated discharge hose. 3C. Sewage remaining in discharge line	3A. Remove and flush bowl with pressure hose to remove all material. Install strainer in intake line to avoid recurrence. 3B. Replace hose with Raritan sanitation hose (#SFH). 3C. Flush toilet longer; replace hose if permeated; reroute hose making a shorter run if possible.
4. Bowl fills while underway.	4A. Pressure buildup at seacocks.	4A. Close intake, then discharge seacock to determine which is causing problem. If discharge, be sure the vent or vented loop is clean. If intake, there is too much pressure on seacock; contact Raritan Technical Support.
5. Water leaking from under unit.	5A. Leaking Bowl Throat adapter. 5B. Leak at shaft seal. 5C. Leak from bowl spud. 5D. Leak at vacuum breaker	5A. Tighten adapter clamps. 5B. Check seal and motor shaft. 5C. Check and reseal bowl grommet 5D. Clean by gently pressing downward and turn clockwise 1/4 and remove cap and remove plastic piston and clean. Replace if needed.

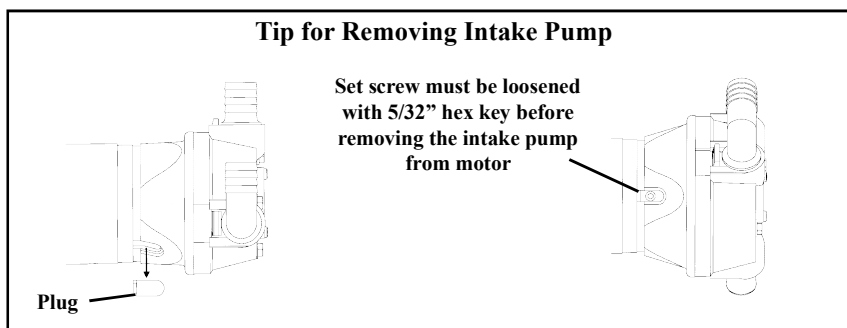

ATLANTES FREEDOM VORTEX VAC PARTS LIST ELONGATED

EXPLODED PARTS

ItemNo.	Part No.	Description
1	241101SC	Seat & Cover Slow Close (White)
1	AL030ASC	Seat & Cover Slow Close (Almond)
2	AL002W	Atlantes Bowl Elongated (White)
2	AL002AW	Atlantes Bowl Elongated (Almond)
3	M23A	#10 Lockwasher SS
4	1108A	10-32 SS Nut
5	53145	Macerator Blade
6	31-102	Motor Shaft Seal
7	221110	Discharge Pump Seal Plate
8	221105	O-Ring
9	161115	Impeller
10	221115	Discharge Pump Macerator Housing
11	31-114	Lock Nut 10-32 W/Nylon(3)
12	221012	Discharge Motor 12 V
12	221024	Discharge Motor 24V
13	221125	Bowl Throat Adapter Clamp-Pump
14	AM221120	Bowl Throat Adapter
15	221126	Bowl Throat Adapter Clamp-Bowl
16	F035	Isolation Nut (2)
17	CH57	Rubber slinger
19	AM021	Pump Mounting Bracket
20	221127	Discharge Motor Mounting Clamp
21	221141W	Discharge Hose (includes part #s 22 thru 26)
21A	VLVE	Vent Valve Assembly
21B	FC001A	Vent Valve Clamp
22	221135W	Joker Valve (2) (includes part 24)
23	221145	Discharge Adapter Fitting
24	221146	Joker Valve Insert
25	221160	Discharge Hose Clamp (small)
26	221165	Discharge Hose Clamp (large)
27	F089	Screw: 1/4-20x 2" (2)
28	AM028	Bushing(2)
29	1236AW	Spud Assembly w/ BLACK seal
29	1236AWR	Spud Assembly w/ RED seal

REMOTE INTAKE PUMP

30	166012A	Pump Motor 12 volt
30	166024A	Pump Motor 24 volt
31	166000	Complete Remote Pump 12 VDC
31	166100	Complete Remote Pump 24 VDC
39	162420	Fitting Clip (3)
40	162000W	Remote Intake Pump w/o Motor (includes parts 3, and 39 thru 46)
41	162410	3/4" Hose Barb Straight
42	162425	O-Ring (3)
43	162415	Plug Fitting
44	162405	3/4" Hose Barb 90° Fitting
45	F162VT	Inlet Pump Mounting Bolt (4)
46	F144	#10 Washer SS Flat (4)
50	1236E	Bowl Elbow
51	AM012	Nipple
52	AM011	Elbow

PRESSURIZED FRESH WATER UNITS

60	221362	Y Fitting
61	221353	Solenoid Valve 12VDC D90
61	221354	Solenoid Valve 24VDC D90
62	221358W	Inlet Adapter Assembly 90 Degrees
63	221361	Sealing Washer
64	F201	Screw: M4 x 10mm SS Phillips
65	PLA29	Elbow: 3/4 FPT x 1/2 Barbed
66	SF50W	SEA FRESH: CHECK VLV HG
67	221361	Sealing Washer

BOWL MOUNTED FLUSH HANDLE

69	F104	Brass Panel Hex Nut
70	AM665W	Handle SS W/Set Screw
71	AV600W	Flush Control & Wire Harness
72	ETB3	Terminal Block 3 Poles
73	F108	Screw #4 x 7/8" (2)
74	HLWQB	1/4" Split Lock Washer (4)
75	M31	1/4" Brass Flat Washer (8)
76	31-722	Nylon Shoulder Washer (2)
77	F069	1/4" Fiber Washer (2)
78	HSB1	1/4-20 Brass Screw (2)
79	M30	1/4-20 Brass Nut

SMART TOILET CONTROL

STC	Complete Smart Toilet Control Kit (12 & 24 VDC)	
STCBL	Complete Bluetooth STC Kit (12 & 24 VDC)	
80	STC548W	STC Circuit Board w/Enclosure (12 & 24 VDC)
80	STC566W	Bluetooth STC Circuit Board w/Enclosure (12 & 24 VDC)
81	STC545	Control Cable 7 ft
82	221524	Wall Switch Cover Plate (White)
82	221524A	Wall Switch Cover Plate (Almond)
83	STC543W	Touch Wall Panel w/Back Plate
N/S	STC564	Bluetooth Touch Wall Panel w/Back Plate
84	221525	Touch Panel Gasket

MULTIFUNCTION FLUSH PANEL (NOT SHOWN)

221600	Complete Multifunction Control Kit
221524	Wall switch plate
221601	Fill/Empty Switch
221602	Flush Switch
221603	Switch Actuator-Flush, Horizontal Panel
221604	Switch Actuator-Fill/Empty, Horizontal Panel
221605	Switch Actuator-Flush, Vertical Panel
221606	Switch Actuator-Fill/Empty, Vertical Panel

REPAIR/ REPLACE KITS

MERK	Discharge Pump Repair Kit (includes part #s 6, 8 and 22)
DIAPUMPRK	Intake Pump Repair Kit
2210012	12 VDC Discharge Assembly (includes part #s 3 thru 12 and 21 thru 26)
2210024	24 VDC Discharge Assembly (includes part #s 3 thru 12 and 21 thru 26)
162400	Fitting Kit (includes parts 39, 41, 42, 43, 44)

PARTS NOT SHOWN

RTME12D	Power Converter for 120/240VAC UNIT
221170	Discharge Hose Strap
221335	Hose, 1/2 inch
221340	Hose Clamps, 1/2 inch
F071	Nylon Shoulder Washer (2)
VCAP	Vinyl Cap (White) (2)
VCAPA	Vinyl Cap (Almond) (2)

OPTIONAL ACCESSORIES AVAILABLE FROM RARITAN

91	221147	1 1/2" Thru Wall Discharge Kit
92	221148	1" Thru Wall Discharge Kit
1PCP32	C.P. Cleans Potties, 32 OZ	
1PCHGAL	Cleans Hoses, Tanks and MSD (gal.)	
SFH	Sanitation Hose 1 1/2" (sold by foot)	
SFH1	Sanitation Hose 1" (sold by foot)	
163000	Raw Water Strainer	
190601	Fresh Water Strainer	

N/S Not Shown

Atlantes Freedom Vortex Vac Exploded Parts View - Elongated

EXPLODED PARTS

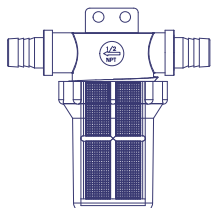
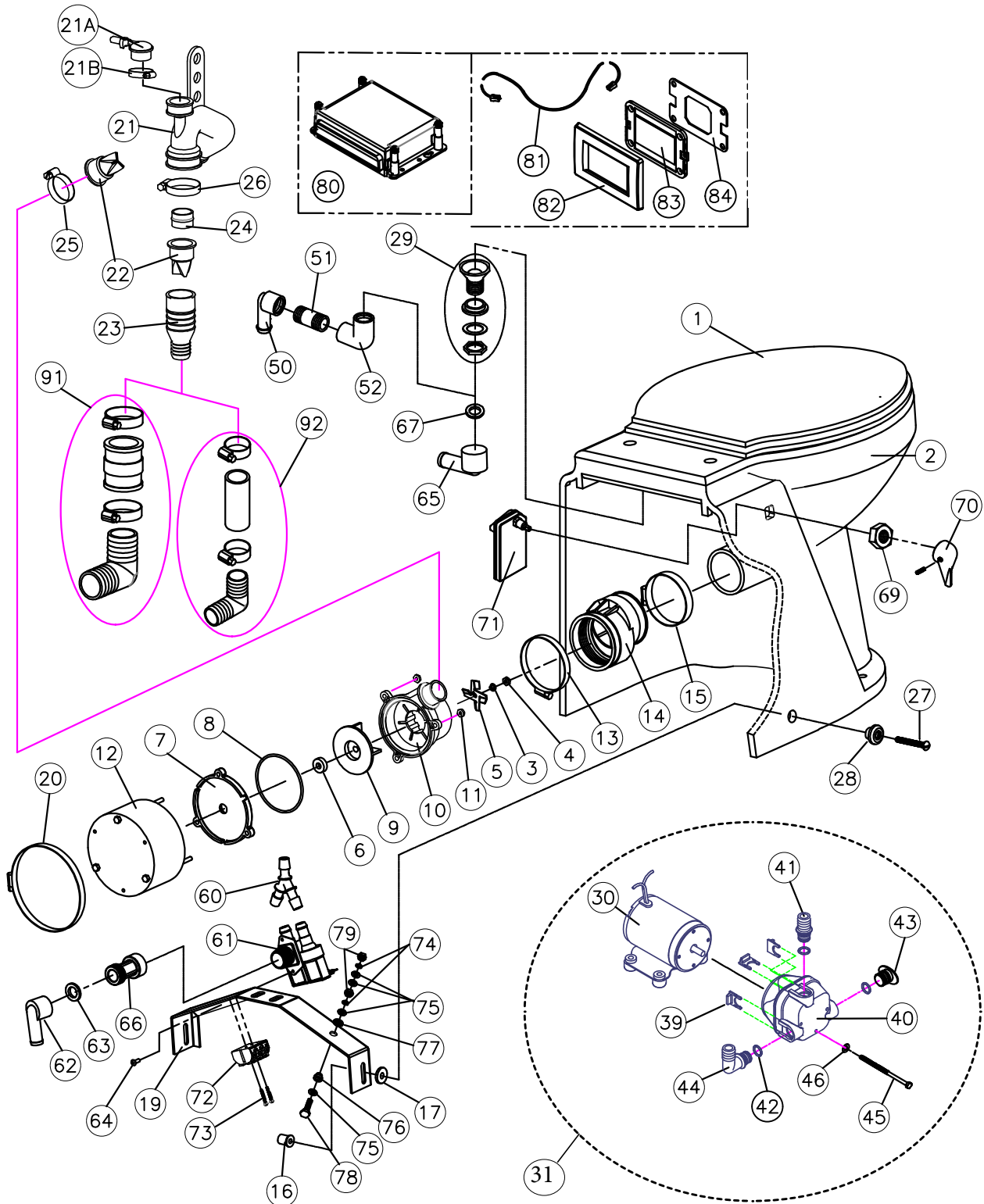

Optional Raw
Water Strainer
Part# 163000

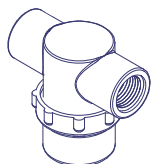

Optional Pressurized
Fresh Water Strainer
Part# 190601

LIMITED WARRANTY

Raritan Engineering Company warrants to the original purchaser that this product is free of defects in materials or workmanship for a period of one year from the product's date of purchase. Should this product prove defective by reason of improper workmanship and/or materials within the warranty period, Raritan shall, at its sole option, repair or replace the product.

1. TO OBTAIN WARRANTY SERVICE, Consumer must deliver the product prepaid, together with a detailed description of the problem, to Raritan at 530 Orange St., Millville, N.J. 08332. When requesting warranty service, purchaser must present a sales slip or other document which establishes proof of purchase. THE RETURN OF THE OWNER REGISTRATION CARD IS NOT A CONDITION PRECEDENT OF WARRANTY COVERAGE. However, please complete and return the owner Registration Card so that Raritan can contact you should a question of safety arise which could affect you.
2. THIS WARRANTY DOES NOT COVER defects caused by modifications, alterations, repairs or service of this product by anyone other than Raritan; defects in materials or workmanship supplied by others in the process of installation of this product; defects caused by installation of this product other than in accordance with the manufacturer's recommended installation instructions or standard industry procedures; physical abuse to, or misuse of, this product. This warranty also does not cover damages to equipment caused by fire, flood, external water, excessive corrosion or Act of God.
3. ANY EXPRESS WARRANTY NOT PROVIDED HEREIN, AND ANY REMEDY FOR BREACH OF CONTRACT WHICH BUT FOR THIS PROVISION MIGHT ARISE BY IMPLICATION OR OPERATION OF LAW, IS HEREBY EXCLUDED AND DISCLAIMED. ALL IMPLIED WARRANTIES SUCH AS THOSE OF MERCHANTABILITY AND OF FITNESS FOR A PARTICULAR PURPOSE, IF APPLICABLE, AS WELL AS ANY IMPLIED WARRANTIES WHICH MIGHT ARISE BY IMPLICATION OF LAW, ARE EXPRESSLY LIMITED TO A TERM OF ONE YEAR. SOME STATES DO NOT ALLOW LIMITATIONS ON HOW LONG A LIMITED WARRANTY LASTS, SO THE ABOVE LIMITATION MAY NOT APPLY TO YOU.
4. UNDER NO CIRCUMSTANCES SHALL RARITAN BE LIABLE TO PURCHASER OR ANY OTHER PERSONS FOR ANY SPECIAL OR CONSEQUENTIAL DAMAGES, WHETHER ARISING OUT OF BREACH OF WARRANTY, BREACH OF CONTRACT, OR OTHERWISE. SOME STATES DO NOT ALLOW THE EXCLUSION OR LIMITATION OF INCIDENTAL OR CONSEQUENTIAL DAMAGES, SO THE ABOVE LIMITATION OR EXCLUSION MAY NOT APPLY TO YOU.
5. No other person or entity is authorized to make any express warranty, promise or affirmation of fact or to assume any other liability on behalf of Raritan in connection with its products except as specifically set forth in this warranty.
6. This warranty gives you specific legal rights, and you may also have other rights which vary from state to state.



530 Orange Street, Millville, NJ 08332 USA
Telephone: 856-825-4900 FAX: 856-825-4409
www.raritaneng.com