

ATLANTES FREEDOM™ TOILET with VORTEX-VAC™

Installation and Maintenance Instructions MODEL AVL (ELONGATED BOWL)

THE FOLLOWING ARE CAUTIONARY STATEMENTS THAT MUST BE READ AND FOLLOWED DURING INSTALLATION, MAINTENANCE AND OPERATION.

WARNING: *Raritan Engineering Company, Inc. recommends that a qualified person or electrician install this product. Equipment damage, injury to personnel or death could result from improper installation. Raritan Engineering Company, Inc. accepts no responsibility or liability for damage to equipment, injury or death to personnel that may result from improper installation or operation of this product.*



WARNING: HAZARD OF SHOCK OR FIRE



Always use recommended fuse, circuit breaker and wire size.

Motors used with this product are “Ignition Protected”. They are not however, explosion-proof.

DO NOT run continuously for more than 30 seconds.

WARNING: HAZARD OF FLOODING



Always shut off seacock(s) before leaving the boat unattended. Double clamp all below waterline hose fittings and check frequently for integrity.

Description:

Atlantes Freedom with Vortex-Vac elongated toilet is available in white or bone finishes, with 12 VDC, 24 VDC, 120/240V AC power options.

Water Source Options:

Fresh Water Model uses pressurize onboard fresh water.

Raw Water Pump Model uses a remote intake pump to supply raw (outside) water to the bowl.

Sea/Fresh Model can switch between fresh and raw water source.

Flush Control Options:

Flush Handle Control: Provides momentary operation of flush water and discharge. Available in momentary or timed.

Smart Toilet Control (STC): Provides timed operation and independent control of flush water and discharge with handle or wall switch.

Multifunction Flush Panel

221600 (White) or 221600B (Black): Provides momentary operation and independent momentary control of water fill and discharge.

Bluetooth Flush Control (STCBL):

Provides timed operation and independent control panel wirelessly up to 50' [15 m] away. Eliminates the need to route wires through bulkheads and cabinetry.

Pressurized Fresh Water Model



Remote Raw Water Pump Model



1-800-352-5630

www.raritaneng.com

IMPORTANT SAFETY INSTRUCTIONS:**Below-Waterline Installation Requirements**

Toilets installed at or below the vessel's waterline and equipped with an overboard discharge option must have a properly installed vented loop in the discharge line. The vented loop must be installed in accordance with the vented loop manufacturer's installation instructions.

Raw Water Intake Systems

Units installed below the waterline and equipped with a remote raw water pump must also have a vented loop installed in the intake line between the discharge side of the raw water pump and the toilet bowl inlet connection. Double clamp all below waterline connections.

Always replace circuit breaker and fuses with same rating. Use Raritan parts to maintain ignition protection requirements.

WARNING:

Young children should NOT be left unsupervised around toilet. Serious injury or death could occur. DO NOT place hands in toilet bowl without disconnecting power. A sharp blade is used for maceration of waste. Children can drown in water retained in the bowl. Seat and/or lid could close and strike child.

**Install the Warning Label (L322)
where it can be easily seen.**

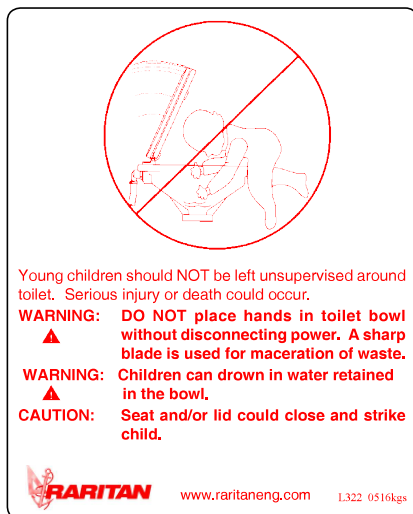
**FLUSH GUIDELINES****DO Flush**

Human Waste and Toilet Paper

DO NOT Flush

Feminine Products, Paper Towels, Wet Wipes or Trash

Raritan recommends:

- Kills Odor (K.O.) for holding tank treatment
- Cleans Potties (C.P.) for ceramic bowl cleaning
- Mild soap and water solution to clean all other components

DO NOT: use general purpose cleaners or other harsh chemicals. Damage to toilet may occur and void warranty.



L110 1225jc

- No special toilet paper is required.
- Water should appear in the bowl within ten seconds. If not, see troubleshooting section.
- Do not flush feminine products, paper towels, wet wipes or trash.
- Always shut off seacock(s) before leaving the boat unattended.

CLEANING

Raritan C.P. (1PCP32) - Cleans Potties, a bio-enzymatic bowl cleaner, will keep the bowl clean and fresh smelling. It is the only factory-recognized cleaning product that may be used in the toilet. A mild soap and water solution can be used for all other components.

DO NOT ADD ANY OTHER CHEMICALS OR CLEANING PRODUCTS TO THE TOILET OR THE TREATMENT SYSTEM.

Recommend Visual Inspection

- ✓ No leaks at toilet and hose connections
- ✓ Hose clamps
- ✓ Condition of hoses
- ✓ Seacocks
- ✓ Condition of wires and connections
- ✓ In-Line Strainer (if installed)

SYSTEM START-UP

1. Open seacock(s).

NOTE: Pressurized fresh water models; open water source valve.

2. Turn on power to toilet.
3. Flush toilet per Flush Control Operation Instructions.
4. Check for leaks.

IMPORTANT: If toilet does not flush properly or if water does not enter the bowl within 10 seconds, refer to Troubleshooting.

WINTERIZING

Winterizing Raw Water Pump Models

- Improper winter lay up is a major cause of marine toilet failure.
- Use only nontoxic antifreeze.
- Flush toilet several times to clear waste from system.
- Dispose of all antifreeze in accordance with local and federal regulations.
- Winterize holding tanks, plumbing, treatment systems (MSD's), etc. independently following manufacturer's instructions.

Parts Required

- 3/4" [19 mm] I.D. intake hose approximately 3' [1 m] long.
- 1" [25 mm] or 1 1/2" [38 mm] I.D. discharge hose approximately 3' [1 m] long.
- Two buckets
- Nontoxic antifreeze approximately 1 quart [1 L]

Steps

1. Close the intake and discharge seacocks.
2. Turn off power to unit.
3. Disconnect and drain pump intake hose and discharge hose.
4. Connect short hoses to toilet's pump intake and discharge.
5. Place one bucket under hose connected to toilet's discharge.
6. Pour nontoxic antifreeze in other bucket.
7. Place hose connected to intake pump into bucket with antifreeze.
8. Turn on power to unit and flush toilet until antifreeze begins to be discharged from toilet.
9. Disconnect power from toilet.

Winterizing Pressurized Fresh Water Models

Parts Required

- 1" [25 mm] or 1 1/2" [38 mm] I.D. discharge hose, approximately 3' [1 m] long
- Two buckets
- Nontoxic antifreeze approximately 1 quart [1 L]

Steps

1. Close discharge seacock (if one exists).
2. Shut off intake water at source.
3. Turn off power to unit.
4. Disconnect and drain intake and discharge hose.
5. Disconnect intake hoses from toilet and place in one of the buckets.
6. Connect short hose to toilet's discharge and place in other bucket.
7. Pour antifreeze in bowl.
8. Turn on power to unit and flush until antifreeze is removed from the bowl and water is drained from the solenoid and hose.
9. Disconnect power to toilet.
10. Reconnect intake hoses to water solenoid.

RECOMMISSIONING

1. Using the buckets, hoses and approximately 1 gallon [3.8 L] of clean fresh water, flush antifreeze out of the toilet (see Winterizing). Dispose of antifreeze in accordance with local and federal regulations.
2. Reconnect the intake and discharge hoses and open both seacocks and water source valve.
3. Check all connections for leaks with several test flushes.

Plumbing

Maximum suction of Intake pump (Maximum height above waterline)	4' [1.2 m] from Intake Pump
Maximum height of discharge vented loop	10' [3 m] from base of toilet
Pressurized water source minimum requirements	Minimum flow rate 3 gallons [11.5 L] per minutes, minimum pressure 5 PSI [34.5 kPa]

NOTES: for Wiring

1.	Distances are from source to unit and back to source.
2.	Distance from power source to remote intake pump MUST be included when determining total distance. Same wire size MUST be used for lower base and remote intake pump.
3.	Recommended conductor wire minimum AWG [mm ²] for 3% voltage drop.
4.	Recommended conductor sizes are based on 105°C rated insulation. Refer to ABYC Standards for other insulation ratings.
5.	For 120/240 VAC units use 12VDC specifications from transformer to unit.

Hose Sizes

Inlet:
 1/2" [13 mm] for Fresh Water Model
 3/4" [19 mm] for Raw Water Model
Discharge:
 1" [25 mm] or 1 1/2" [38 mm]

CONVERSIONS								
Wire - AWG to mm ²								
AWG	16	14	12	10	8	6	4	2
mm²	1.5	2.5	4.0	6.0	10.0	16.0	25.0	35.0
Feet to Meters								
Feet	10	15	20	25	30	40	50	
Meter	3.1	4.6	6.1	7.6	9.2	12.2	15.2	

Recommended Wire and Fuse/Circuit Breaker Sizes

Raw Water Model (sizes based on both remote intake and discharge pumps amps added together)

Units Voltage	Circuit Breaker/ Fuse size	Toilet Discharge Pump amp draw	Remote Intake Pump amp draw	10 feet	15 feet	20 feet	30 feet	40 feet	50 feet
12 VDC	30	18	10	10 AWG	8 AWG	6 AWG	4 AWG	4 AWG	2 AWG
24 VDC	20	10	5	16 AWG	14 AWG	12 AWG	10 AWG	10 AWG	8 AWG

Pressurized Fresh Water Model

Units Voltage	Circuit Breaker/ Fuse size	Amp draw	10 feet	15 feet	20 feet	30 feet	40 feet	50 feet
12 VDC	25	18	10 AWG	10 AWG	8 AWG	6 AWG	6 AWG	4 AWG
24 VDC	15	10	16 AWG	16 AWG	14 AWG	12 AWG	10 AWG	10 AWG

Remote Intake Pump Only (Raw and Sea/Fresh Models)

Units Voltage	Circuit Breaker/ Fuse size	Amp Draw	10 feet	15 feet	20 feet	30 feet	40 feet	50 feet
12 VDC	15	10	14 AWG	12 AWG	10 AWG	10 AWG	8 AWG	6 AWG
24 VDC	10	5	16 AWG	16 AWG	16 AWG	16 AWG	14 AWG	12 AWG

**Atlantes discharge Maximum recommended:
 1" [25 mm] or 1 1/2" [38 mm] hose length**

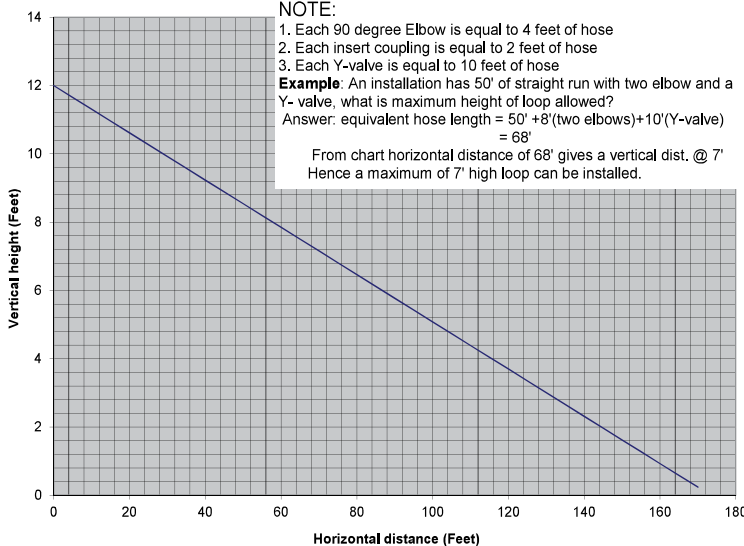

Water Consumption:
 Water Saver: 2 pint* [.95 L]
 Regular Flush: 2 quarts [1.9 L]
 * requires timing adjustment

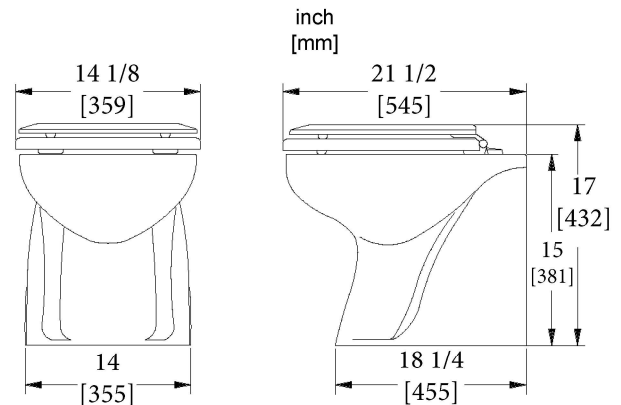

Parts included with all models:

1. Toilet bowl assembly
2. Seat and Cover
3. Flush control - includes QR code for Operation and Installation Guides
4. QR code for Installation and Maintenance Guide
5. Warning Labels

Parts included with Raw Water Model:

1. Remote pump assembly
2. Sea/Fresh models include relay for remote pump

Additional parts required (not included):

- 1" [25 mm] or 1 1/2" [38 mm] I.D. discharge hose
- Reinforced intake hose:
Raw: 3/4" [19 mm]
Fresh: 1/2" [13 mm]
- 3/4" [19 mm] and 1" [25 mm] or 1 1/2" [38 mm] hose clamps (two for each connection below waterline)
- Wire (See specification chart)
- Terminals
- Fuse/circuit breaker (See specification chart)
- Strainers are optional and recommended:
 Fresh Water Strainer (190601)
 In-Line Strainer (163000)

MOUNTING

1. Place toilet where it will be located.
Make sure there is room to route hoses.
Make sure seat will open properly.
2. Using a pencil, mark location of bowl mounting holes (FIG 2).
3. A. If hoses will be routed through floor, trace one side of toilet on floor.
 B. If hoses will be routed through wall, trace one side of toilet on wall.
4. Remove toilet and mark location for hoses and wiring on deck or wall.
5. Cut necessary holes for hoses and wiring.

NOTE: Check outside diameter of hoses and adjust accordingly.

- **Discharge Hose Opening:**
 1 1/2" Hose: 2" [51 mm]
 1" Hose: 1 1/2" [38 mm]
- **Inlet Hose Opening:**
 FRESH: 7/8" [22 mm]
 RAW: 1" [25 mm]
- **Wiring Hole Opening:**
 3/4" [19 mm]

6. Drill holes for toilet mounting bolts/screws.

NOTE: Use 1/4" [6 mm] size bolts/screws. To select proper screw or bolt length, measure thickness of deck plus 1 1/8" [29 mm].

TIP: Do not install until all wiring and plumbing is done. Secure toilet to floor after installation is complete.

Mounting Toilet

1. Connect plumbing and wiring before mounting toilet.
2. Tighten bolts being careful to not overtighten (Do not exceed 30 inch lb. when tightening).
3. Install caps over mounting bolts.

**Mounting surface must be flat and solid.
 Seat must open more than 90 degrees.**

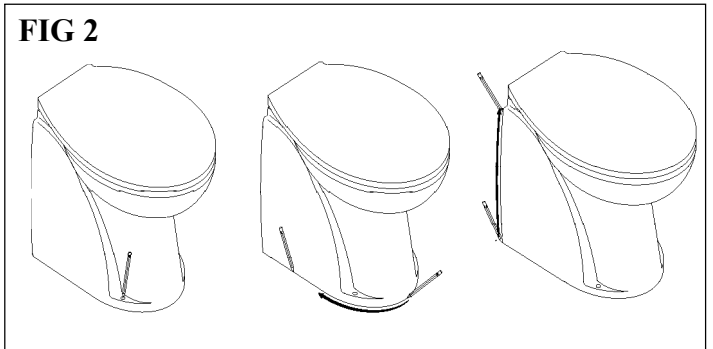
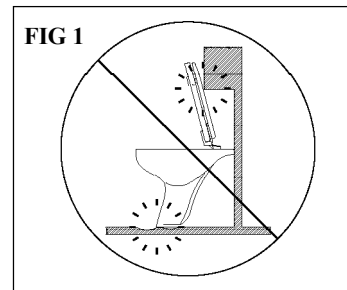

CAUTION: Do Not over tighten mounting bolts. Damage to the toilet bowl may occur. Tighten both mounting bolts evenly and slowly.

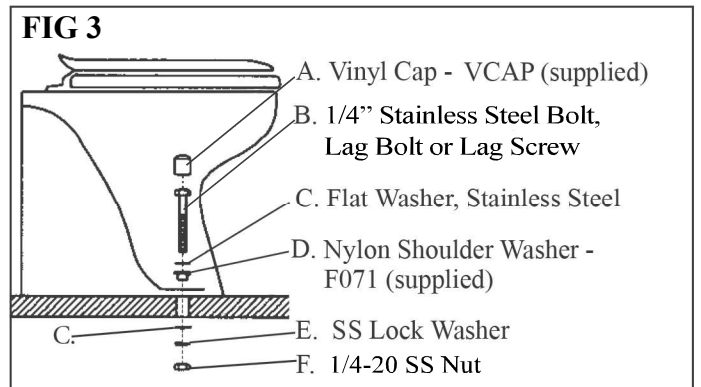

PLUMBING

PLUMBING

WARNING: HAZARD OF FLOODING

Toilets mounted at or below the waterline, at greatest angle of heel, and connected to a Seacock/Thru Hull Fitting(s) **MUST** have **VENTED LOOPS** installed in toilet discharge plumbing and between raw water intake pump and toilet bowl.

Install vented loops per manufacturer's instructions. Double clamp all below-waterline connections.

IMPORTANT

- Discharging untreated sewage is forbidden in all U. S. waters within the three-mile limit and 9 miles in Gulf of America.
- Fittings and 90° bends should be kept to a minimum.
- In-Line Strainer may be installed on raw water models to prevent clogs.
- Thru-hull fittings and seacocks must be installed where they are easily accessible.
- Use only quality reinforced hoses such as Raritan SANIFLEX HOSE.
- Secure all hoses properly.

Residual Water in the Bowl

The Atlantes toilet includes an integral vent that maintains up to 4" [10 cm] of water in the bowl. In most installations, this built-in feature does not require any adjustment. In the event the bowl water is being siphoned empty, removing of the vent cap (FIG 8) will help retain water in the bowl.

NOTE: If any portion of the discharge hose is routed higher than the internal integral vent, **DO NOT** remove the vent cap.

To enable Integral Vent, remove Vent Cap (FIG 8), connect 1/4" hose and connect hose to a deck vent fitting (Reference FIG 6). Hose and deck fitting not included.

FIG 5 Pressurized Fresh Water Model installed below waterline

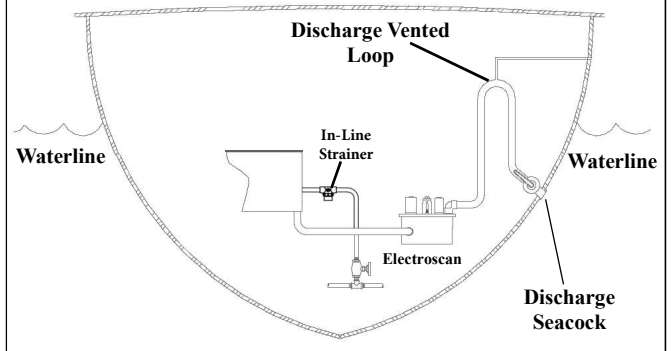

FIG 6 Remote Raw Water Pump Model mounted below waterline

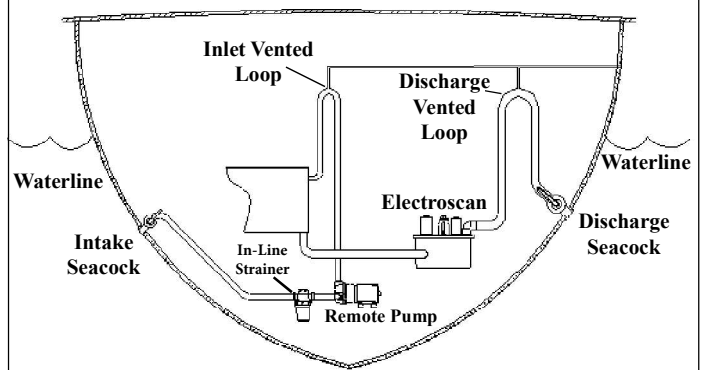
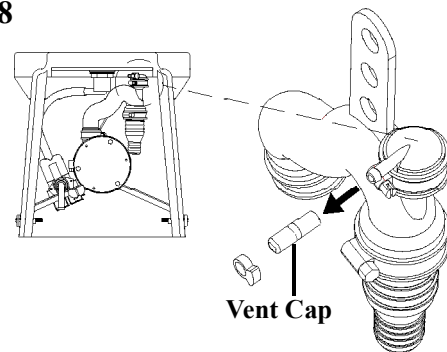

FIG 7 Toilet installed below waterline or below Treatment Device and or holding Tank = Upward discharge flow, **Do not remove vent cap**



FIG 8



Discharge Lines

Raritan Sanitation Hose is recommended

SaniFlex Hose Part numbers:

SFH 1 1/2 inch [38 mm]

SFH1 1 inch [25 mm]

1. Connect sanitation hose to discharge fitting on toilet.

NOTE: Discharge fitting is designed for 1" [25 mm] or 1 1/2" [38 mm] hose. 1 1/2" [38 mm] hose is secured at top of fitting and 1" [25 mm] is secured at the bottom. It is not necessary to remove the 1" [25 mm] barb if using 1 1/2" [38 mm] hose. Use the fitting as is.

2. Run hose to appropriate device (e.g.: treatment system, holding tank, etc.).

NOTE: If installation requires routing through the backwall rather than the floor, 90 degree kits are available:

221147 for 1 1/2" [38 mm] hose

221148 for 1" [25 mm] hose.

Intake Lines

Pressurized Fresh Water Models

NOTE: To avoid malfunction of water solenoid due to debris in water, installation of Fresh Water Strainer (190601) is recommended.

1. Connect 1/2" [13 mm] I.D. hose to pressurized fresh water supply.

2. Install a shut off valve in intake line before toilet.

3. Connect hose from shut off valve to inlet fitting of water solenoid valve at the toilet.

Mounting Remote Pump

1. Remote pump uses 3/4" [19 mm] ID hose for connection. Preferably at or slightly above waterline.

2. Locate remote pump between thru hull fitting and toilet bowl.

3. Locate in an area away from berth to keep noise level down.

4. Use In-Line Strainer, part 163000 (recommended) to avoid clogs.

5. Secure remote pump to the floor using four bolts through the pump base (FIG 10).

Connecting Remote Pump

Remote pump fittings are interchangeable to allow more flexibility during installation. Inlet ports are located on either side of intake pump. Outlet port (to toilet bowl) is at top of intake pump (FIG 11).

NOTE: To avoid poor pump performance installation of In-Line Strainer (163000) is recommended

1. Slide fitting clips to open position (FIG 12)

2. Select inlet port to be used.

3. Install appropriate fittings into inlet and outlet ports.

NOTE: The 90° fitting can be rotated 360°.

4. Install the plug fitting into unused inlet port.

IMPORTANT: DO NOT install plug fitting into outlet port! Damage to pump will occur!

5. Slide fitting clips back to closed position (FIG 12).

6. Connect hose from seacock to inlet port of intake pump. If used, strainer is in-line. Use hose clamp provided.

IMPORTANT: Double clamp all below waterline hose connections!

7. Connect hose from outlet port of intake pump to bowl elbow located on back of toilet bowl.

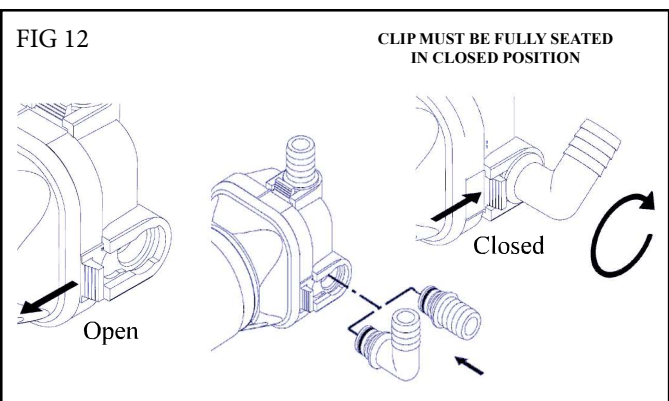
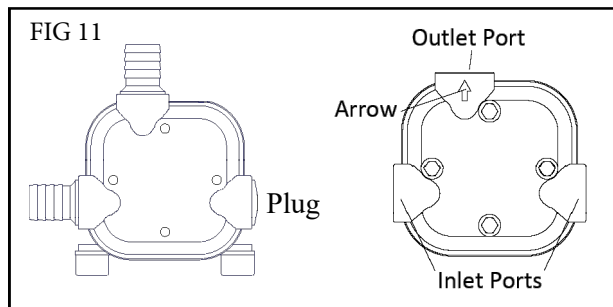
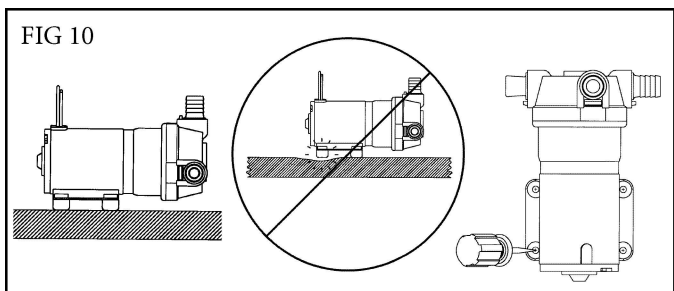
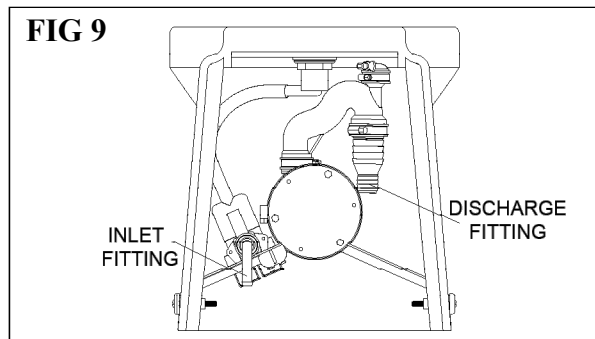

**WIRING FLUSH CONTROLS
FOLLOW THE INSTRUCTIONS INCLUDED
WITH FLUSH CONTROL**

Connect hoses and wiring to toilet

- Route wire from control per wiring diagrams.
- Install seat. Install discharge support strap between seat nut and the bowl (FIG 13).

Caution: To avoid kinking, do not pull on the discharge hose. Be certain there is no pressure on the discharge line.

Mount toilet

- Install mounting bushings, bolts. (FIG 14)
- Tighten bolts being careful to not overtighten (Do not exceed 30 inch lb. when tightening)
- Install caps over mounting bolts.

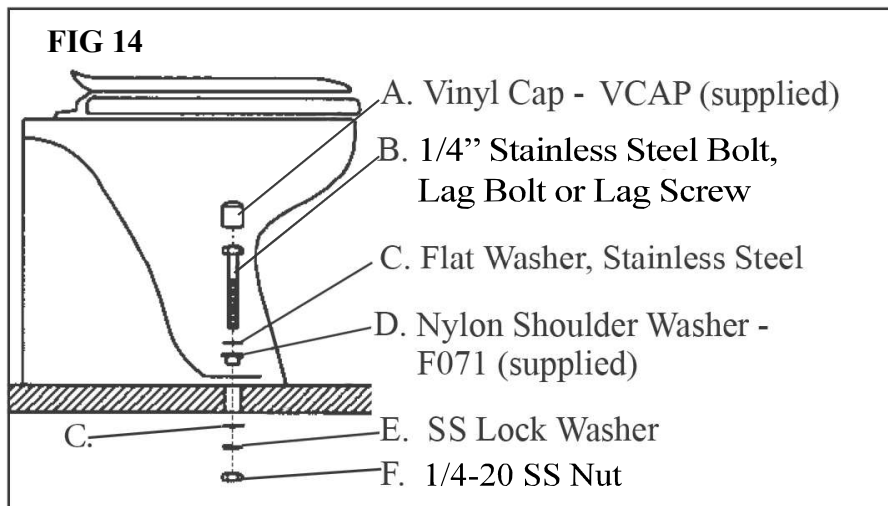
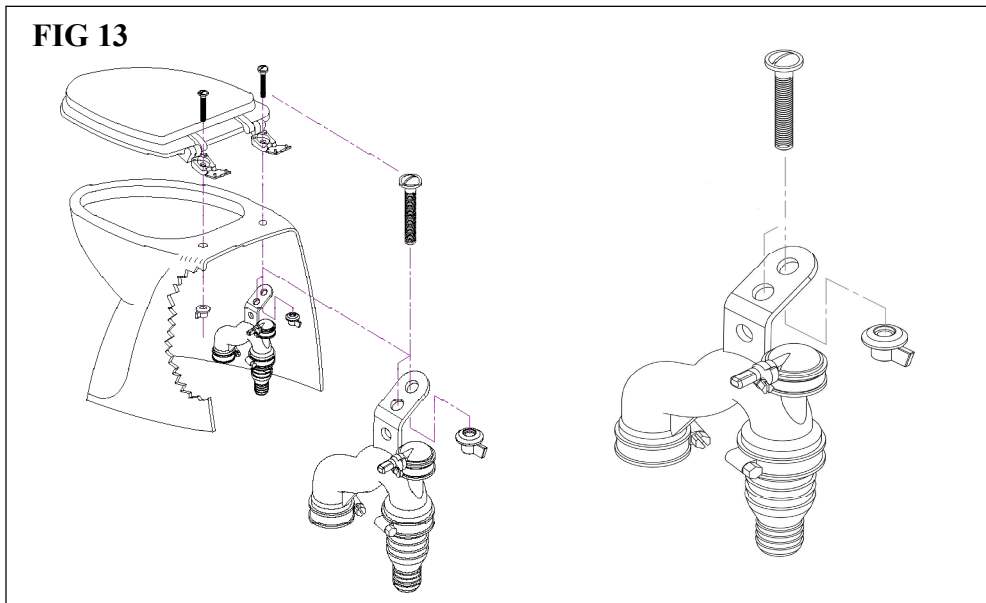

TROUBLESHOOTING

WARNING: HAZARD OF ELECTRIC SHOCK - Before beginning any work on the toilet, be sure that all power to the unit has been turned off.

WARNING: HAZARD OF FLOODING - Make sure seacocks are in the CLOSED or OFF position before working on toilet.

NOTE: The following information reflects the most probable causes and solutions to problems although not every possible cause and solution is provided.

Any questions regarding servicing or operation of the Marine Elegance should be directed to our Technical Support Department in Millville, NJ. Please have model and serial number available before calling.

PROBLEM	POSSIBLE CAUSE	SOLUTION
1. Poor pump out, especially solids.	1A. Clogged discharge line. 1B. Plumbing restrictions, bends and ells. 1C. Clogged vents. 1D. Mineral buildup in hoses and fittings. 1E. Low voltage.	1A. Be sure discharge seacock is open. Clear line, remove clog. 1B. Replumb to eliminate bends and ells. 1C. Clean holding tank vent and vented loop vents 1D. Clean or replace affected parts. Replace hose if needed. 1E. Check voltage at toilet while toilet is running . If less than nominal voltage of toilet (12 or 24), check condition of batteries and wire sizes. Check terminals and wire connections for corrosion (heat at terminals and junctions indicates a bad or corroded connection).
2. Poor water flow, especially at front of bowl (or no water flow).	2A. Toilet not level. 2B. Restriction in intake line. 2C. Pump sucking air. 2D. Low voltage. 2E. Clogged strainer.	2A. Raise rear of toilet; check with level. 2B. Be sure seacock is open. Clear line-remove clog. 2C. Check all connections from intake thru-hull to intake pump to be sure no air leaks are present. 2D. See 1E, above. 2E. Remove or Clear debris from strainer.
3. Foul odors from toilet area.	3A. "Marine life" lodged in rim of bowl. 3B. Permeated discharge hose. 3C. Sewage remaining in discharge line	3A. Remove and flush bowl with pressure hose to remove all material. Install strainer in intake line to avoid recurrence. 3B. Replace hose with Raritan sanitation hose (SFH). 3C. Flush toilet longer; replace hose if permeated; reroute hose making a shorter run if possible.
4. Bowl fills while underway.	4A. Pressure buildup at seacocks.	4A. Close intake, then discharge seacock to determine which is causing problem. If discharge, be sure the vent or vented loop is clean. If intake, there is too much pressure on seacock; contact Raritan Technical Support.
5. Water leaking from under unit.	5A. Leaking Bowl Throat adapter. 5B. Leak at shaft seal. 5C. Leak from bowl spud. 5D. Leak at vacuum breaker	5A. Tighten adapter clamps. 5B. Check seal and motor shaft. 5C. Check and reseal bowl grommet 5D. Clean by gently pressing downward and turn clockwise 1/4 and remove cap and remove plastic piston and clean. Replace if needed.

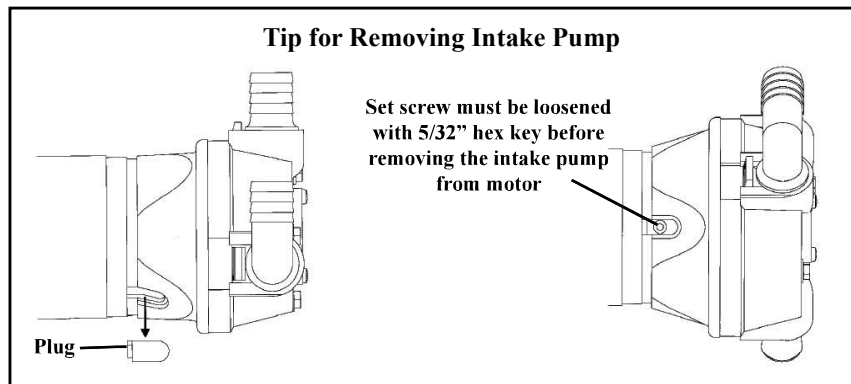

Atlantes Freedom With Vortex Vac Parts List - Elongated

Item #	Part #	Description	BOWL MOUNTED FLUSH HANDLE		
1	241101SC	Seat & Cover Slow Close (White)	70	AM665W	Handle SS w/Set Screw
1	AL030ASC	Seat & Cover Slow Close (Bone)	70a	F104	Brass Panel Hex Nut
2	AL002W	Atlantes Bowl Elongated (White)	71	AV600W	Flush Control & Wire Harness
2	AL002AW	Atlantes Bowl Elongated (Bone)	72	ETB3	Terminal Block 3 Poles
3	M23A	#10 Lock Washer SS	73	F108	Screw #4 x 7/8" (2)
4	1108A	10-32 SS Nut	74	HLWQB	1/4" Split Lock Washer (4)
5	53145	Macerator Blade	75	M31	1/4" Brass Flat Washer (8)
6	31-102	Motor Shaft Seal	76	31-722	Nylon Shoulder Washer (2)
7	221110	Discharge Pump Seal Plate	77	F069	1/4" Fiber Washer (2)
8	221105	O-Ring	78	HSB1	1/4-20 Brass Screw (2)
9	161115	Impeller	79	M30	1/4-20 Brass Nut
10	221115	Discharge Pump Macerator Housing	SMART TOILET CONTROL		
11	31-114	Lock Nut 10-32 W/Nylon (3)	STC Complete Smart Toilet Control Kit (12 & 24 VDC)		
12	221012	Discharge Motor 12 VDC	STCBL Complete Bluetooth STC Kit (12 & 24 VDC)		
12	221024	Discharge Motor 24 VDC	80	STC548W	STC Circuit Board w/Enclosure (12 & 24 VDC)
13	221125	Bowl Throat Adapter Clamp-Pump	80	STC566W	Bluetooth STC Circuit Board w/Enclosure (12 & 24 VDC)
14	AM221120	Bowl Throat Adapter			
15	221126	Bowl Throat Adapter Clamp-Bowl	81	STC545	Control Cable 7 ft
16	F035	Well Nut (2)	82	221524	Wall Switch Cover Plate (White)
17	CH57	Rubber Slinger	82	221524A	Wall Switch Cover Plate (Bone)
19	AM021	Pump Mounting Bracket	83	STC543W	Touch Wall Panel w/Back Plate
20	221127	Discharge Motor Mounting Clamp	83	STC564	Bluetooth Touch Wall Panel w/Back and Gasket
21	221141W	Discharge Hose (includes 22-28)	84	221525	Touch Panel Gasket
22	221135W	Joker Valve (2) (includes 24)	MULTIFUNCTION FLUSH PANEL (NOT SHOWN)		
23	221145	Discharge Adapter Fitting	221600	Multifunction Flush Panel, White	
24	221146	Joker Valve Insert	221600B	Multifunction Flush Panel, Black	
25	221160	Discharge Hose Clamp (small)	221524	Wall Switch Plate, White	
26	221165	Discharge Hose Clamp (large)	221524B	Wall Switch Plate Black	
27	VLVE	Vent Valve Assembly	<u>Black / White</u>		
28	FC001A	Vent Valve Clamp	221601 / 221601W	Fill/Empty Switch	
29	1236AW	Spud Assembly w/ BLACK Seal	221602 / 221602W	Flush Switch	
29	1236AWR	Spud Assembly w/ RED Seal	221603 / 221603W	Switch Actuator-Flush, Horizontal Panel	
30	F089	Screw: 1/4-20 x 2" (2)	221604 / 221604W	Switch Actuator-Fill/Empty, Horizontal Panel	
31	F196	ME: Front Mounting Cap (2)	221605 / 221605W	Switch Actuator-Flush, Vertical Panel	
32	F195	Washer: Cup (2)	221606 / 221606W	Switch Actuator-Fill/Empty, Vertical Panel	
33	F071	Nylon Shoulder Washer (2)			
REMOTE RAW WATER PUMP			REPAIR/ REPLACE KITS		
40	166012A	Intake Pump Motor 12 VDC	MERK	Discharge Pump Repair Kit (includes 6, 8 and 22)	
40	166024A	Intake Pump Motor 24 VDC	DIAPUMPRK	Intake Pump Repair Kit	
41	162000W	Remote Intake Pump w/o Motor (includes 45 and 46)	2210012	12 VDC Discharge Assembly (includes 3-12 and 21-28)	
42	162405	3/4" Hose Barb 90° Fitting	2210024	24 VDC Discharge Assembly (includes 3-12 and 21-28)	
43	162410	3/4" Hose Barb Straight	162400	Fitting Kit (includes 42-44 and 46)	
44	162415	Plug Fitting	PARTS NOT SHOWN		
45	162420	Fitting Retaining Clip (3)	221335	Hose, 1/2"	
46	162425	O-Ring (3)	221340	Hose Clamps, 1/2"	
47	F162VT	Inlet Pump Mounting Bolt (4)	ADDITIONAL (OPTIONAL) ACCESSORIES AVAILABLE FROM RARITAN		
48	F144	#10 Washer SS Flat (4)	91	221147	1 1/2" [38 mm] Thru Wall Discharge Kit
49	166000	Complete Remote Pump 12 VDC	92	221148	1" [25 mm] Thru Wall Discharge Kit
49	166100	Complete Remote Pump 24 VDC	1PCP32	C.P. Cleans Potties, 32 oz	
50	1236E	Elbow Adapter 3/4 FPT x 3/4 Barb	1PCHGAL	Cleans Hoses, Tanks and MSD (gallon)	
51	AM012	Elbow, 3/4, 90°	1PKO32	Kills Odors, 32 oz	
52	AM011	Nipple, 3/4 x 2" PVC	KO2	Deodorant System (Raw water models)	
PRESSURIZED FRESH WATER UNITS			SFH	Sanitation Hose 1 1/2" [38 mm] (sold by foot)	
60	221362	Y Fitting	SFH1	Sanitation Hose 1" [25 mm] (sold by foot)	
61	221353	Solenoid Valve 12 VDC D90	163000	In-Line Strainer	
61	221354	Solenoid Valve 24 VDC D90	190601	Fresh Water Strainer	
62	221358W	Inlet Adapter Assembly 90 Degrees	RTME12D	Power Converter for 120/240 VAC	
63	221361	Sealing Washer	STCTSA	Holding Tank Full Sensor (Stick on) For use with STC Flush Control	
64	F201	Screw: M4 x 10mm SS Phillips	STCFL	Holding Tank Full Sensor (Float Switch) For use with STC Flush Control	
65	PLA29	Elbow: 3/4 FPT x 1/2 Barbed			
66	SF50W	Sea/Fresh: Check Valve HG			

Atlantes Freedom with Vortex Vac Exploded Parts View - Elongated

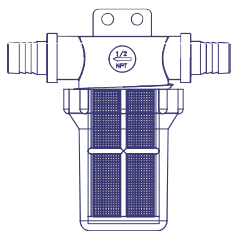
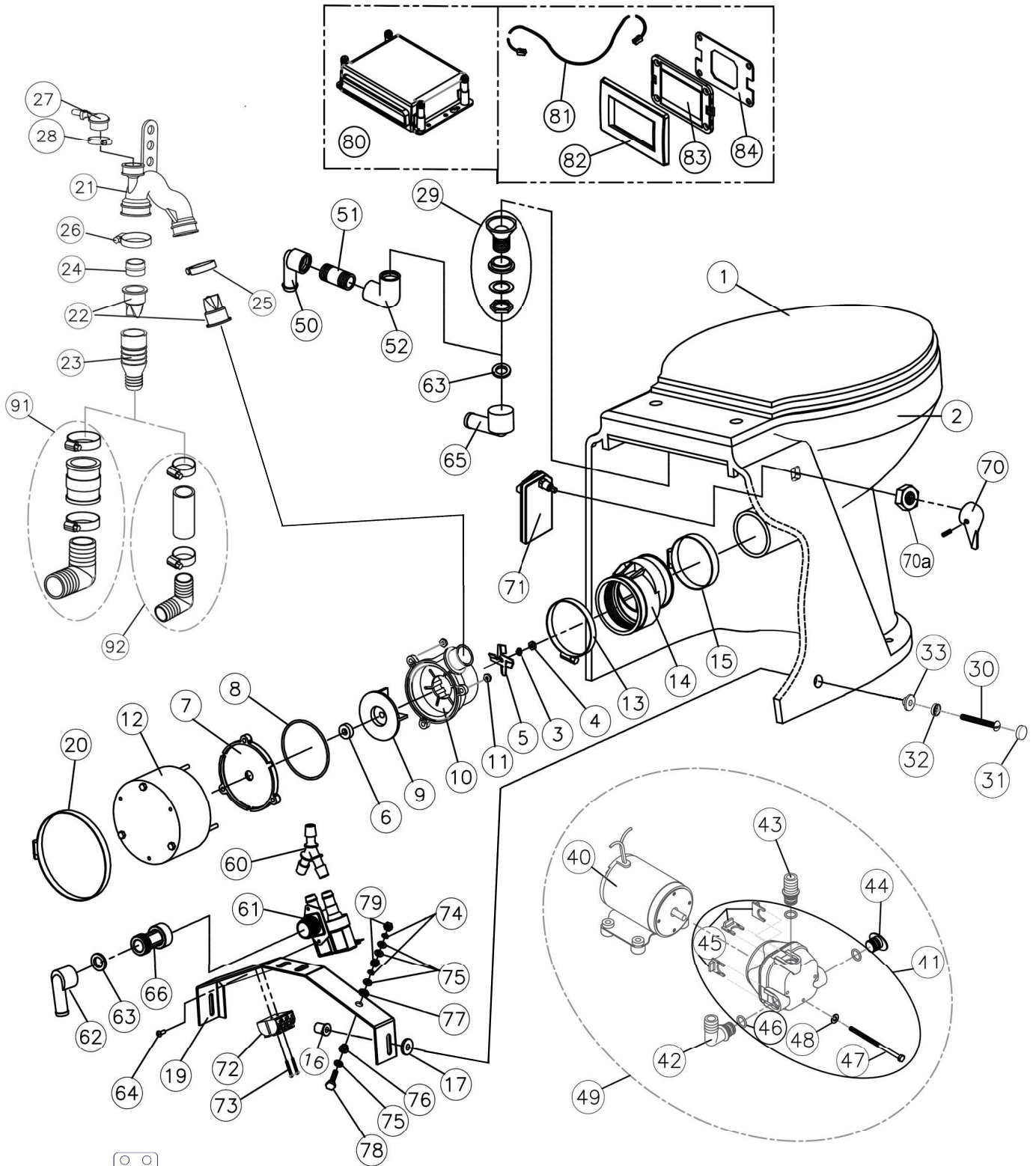

Optional
In-Line Strainer
Part 163000

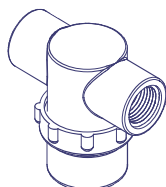

Optional Pressurized
Fresh Water Strainer
Part 190601

LIMITED WARRANTY

Raritan Engineering Company warrants to the original purchaser that this product is free of defects in materials or workmanship for a period of one year from the product's date of purchase. Should this product prove defective by reason of improper workmanship and/or materials within the warranty period, Raritan shall, at its sole option, repair or replace the product.

1. TO OBTAIN WARRANTY SERVICE, Consumer must deliver the product prepaid, together with a detailed description of the problem, to Raritan at 530 Orange St., Millville, N.J. 08332. When requesting warranty service, purchaser must present a sales slip or other document which establishes proof of purchase. THE RETURN OF THE OWNER REGISTRATION CARD IS NOT A CONDITION PRECEDENT OF WARRANTY COVERAGE. However, please complete and return the owner Registration Card so that Raritan can contact you should a question of safety arise which could affect you.
2. THIS WARRANTY DOES NOT COVER defects caused by modifications, alterations, repairs or service of this product by anyone other than Raritan; defects in materials or workmanship supplied by others in the process of installation of this product; defects caused by installation of this product other than in accordance with the manufacturer's recommended installation instructions or standard industry procedures; physical abuse to, or misuse of, this product. This warranty also does not cover damages to equipment caused by fire, flood, external water, excessive corrosion or Act of God.
3. ANY EXPRESS WARRANTY NOT PROVIDED HEREIN, AND ANY REMEDY FOR BREACH OF CONTRACT WHICH BUT FOR THIS PROVISION MIGHT ARISE BY IMPLICATION OR OPERATION OF LAW, IS HEREBY EXCLUDED AND DISCLAIMED. ALL IMPLIED WARRANTIES SUCH AS THOSE OF MERCHANTABILITY AND OF FITNESS FOR A PARTICULAR PURPOSE, IF APPLICABLE, AS WELL AS ANY IMPLIED WARRANTIES WHICH MIGHT ARISE BY IMPLICATION OF LAW, ARE EXPRESSLY LIMITED TO A TERM OF ONE YEAR. SOME STATES DO NOT ALLOW LIMITATIONS ON HOW LONG A LIMITED WARRANTY LASTS, SO THE ABOVE LIMITATION MAY NOT APPLY TO YOU.
4. UNDER NO CIRCUMSTANCES SHALL RARITAN BE LIABLE TO PURCHASER OR ANY OTHER PERSONS FOR ANY SPECIAL OR CONSEQUENTIAL DAMAGES, WHETHER ARISING OUT OF BREACH OF WARRANTY, BREACH OF CONTRACT, OR OTHERWISE. SOME STATES DO NOT ALLOW THE EXCLUSION OR LIMITATION OF INCIDENTAL OR CONSEQUENTIAL DAMAGES, SO THE ABOVE LIMITATION OR EXCLUSION MAY NOT APPLY TO YOU.
5. No other person or entity is authorized to make any express warranty, promise or affirmation of fact or to assume any other liability on behalf of Raritan in connection with its products except as specifically set forth in this warranty.
6. This warranty gives you specific legal rights, and you may also have other rights which vary from state to state.



530 Orange Street, Millville, NJ 08332 USA
Telephone: 856-825-4900 FAX: 856-825-4409
www.raritaneng.com

Thank you for purchasing a Raritan Atlantes Freedom™ Vortex-Vac™ Elongated Style Bowl

Model and Serial #:

Please have this available if support is needed.

SCAN for
Owners Manual



L476

SCAN for
Warranty Form



If you prefer a printed version of the Owners Materials:
Email: info@raritaneng.com

Questions on installation?
Email: techsupport@raritaneng.com



Do not return this product to store.

PLEASE RETAIN FOR YOUR RECORDS

530 Orange Street
Millville, NJ 08332 USA
Telephone: 856-825-4900
FAX: 856-825-4409
www.raritaneng.com



L476 0526 jlc