

# FLUSH HANDLE CONTROL

## Installation and Operation Instructions

**THE FOLLOWING ARE CAUTIONARY STATEMENTS THAT MUST BE READ AND FOLLOWED DURING BOTH INSTALLATION AND OPERATION.**

**WARNING:**



*Raritan Engineering Company, Inc. recommends that a qualified person or electrician install this product. Equipment damage, injury to personnel or death could result from improper installation. Raritan Engineering Company, Inc. accepts no responsibility or liability for damage to equipment, injury or death to personnel that may result from improper installation or operation of this product.*

**WARNING:**

**HAZARD OF SHOCK OR FIRE**



Always use recommended fuse, circuit breaker and wire size.

**DO NOT** install in the area requiring “Ignition Protected” devices.

### FLUSH HANDLE POSITIONS

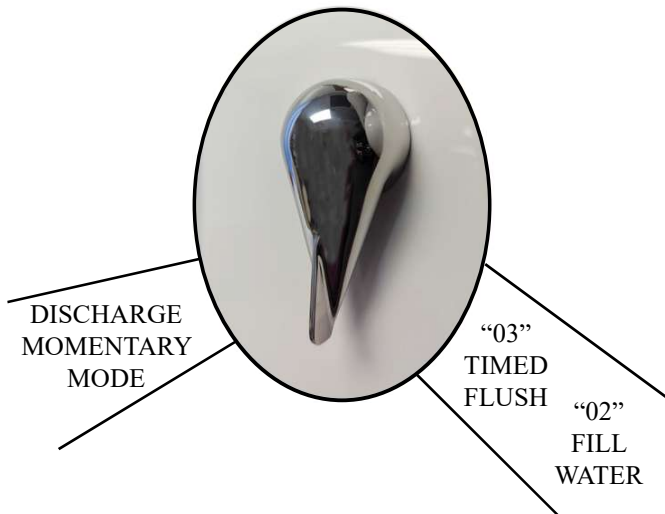

**Push Handle**



**Pull Handle**

### Description:

The term “02” and “03” are related to the last few digits of the model number.

#### “02” model:

The 02 model is designed to work as a momentary unit using only microswitches to activate the motors. It is also a “fail safe” mode for the toilet control in the 03 model.

#### “03” model:

The “03” model includes a smart toilet control with timed operation and retains momentary functionality.

### Operation

**IMPORTANT: Discharge and Inlet Pump / Valve MUST BE wired for proper operation and programming.**

#### Pull Handle Forward:

03 Model - Pull handle forward and release: starts a timed flush, intake pump starts followed by discharge pump.

02 Model - Pull handle forward and hold to add water.

#### Push Handle Backward:

Discharge “dry bowl” flush momentary operation, for both 02 and 03 models.

**If your vessel is equipped with a Marine Sanitation Device (MSD) and you wish to start the MSD from the Toilet Control, follow the steps below:**

03 Models: Electroscan (EST) or Purasan EX/Purasan EX2 (PSTEX/PSTEX2), see page 6, figures 7 and 8.

02 Models or other MSD (such as Purasan, LectraSan MC or EC) Call Raritan Customer Service or visit [www.raritaneng.com](http://www.raritaneng.com)

**NOTES: for Wiring**

1. Distances are from source to unit and back to source.
2. Distance from power source to remote intake pump MUST be included when determining total distance.
3. Recommended conductor wire minimum AWG (mm<sup>2</sup>) for 3% voltage drop.
4. Recommended conductor sizes are based on 105°C rated insulation. Single conductor (not bundled), refer to ABYC Standards for sizes with other insulation ratings.
5. For 120/240 VAC units, use 12 VDC specifications from the transformer to unit.

**CONVERSIONS**

**Wire - AWG to mm<sup>2</sup>**

<b>AWG</b>	16	14	12	10	8	6	4	2
<b>mm<sup>2</sup></b>	1.5	2.5	4.0	6.0	10.0	16.0	25.0	35.0

**Feet to Meters**

<b>Feet</b>	10	15	20	25	30	40	50
<b>Meter</b>	3.1	4.6	6.1	7.6	9.2	12.2	15.2

**Recommended Wire and Fuse/Circuit Breaker Sizes**

**Table 1 Raw Water Model**

(sizes based on both remote intake and discharge pumps amp added together)

Units Voltage	Circuit Breaker/ fuse size (amps)	Toilet Discharge Pump Amps draw	Remote Intake Pump Amp draw	10 feet	15 feet	20 feet	30 feet	40 feet	50 feet
12 VDC	30	18	10	10 AWG	8 AWG	6 AWG	4 AWG	4 AWG	2 AWG
24 VDC	20	10	5	16 AWG	14 AWG	12 AWG	10 AWG	10 AWG	8 AWG

**Table 2 Pressurized Fresh Water Model**

Units Voltage	Circuit Breaker/ fuse size (amps)	Amp draw	10 feet	15 feet	20 feet	30 feet	40 feet	50 feet
12 VDC	25	18	10 AWG	10 AWG	8 AWG	6 AWG	6 AWG	4 AWG
24 VDC	15	10	16 AWG	16 AWG	14 AWG	12 AWG	10 AWG	10 AWG

**Table 3 Remote Intake Pump Only (Raw Water and Sea/Fresh Models)**

Units Voltage	Circuit Breaker/ fuse size (amps)	Amp draw	10 feet	15 feet	20 feet	30 feet	40 feet	50 feet
12 VDC	15	10	14 AWG	12 AWG	10 AWG	10 AWG	8 AWG	6 AWG
24 VDC	10	5	16 AWG	16 AWG	16 AWG	16 AWG	14 AWG	12 AWG

## INSTALLING CONTROL 03 MODELS

**\*\*NOTE:** The panel included is for programming purposes ONLY. It is NOT intended to be mounted for regular use. Please refer to page 6 for programming instructions.

### MOUNTING CONTROL BOX:

1. Locate Control Box near toilet in a dry and accessible area.
2. Using 2 screws, fasten the Control Box to wall with wiring connections at the bottom.
3. Open cover to access wiring connections.
4. Choose one of the wiring diagrams (FIG 1, 2, 3, 4, 5 or 6).
5. Replace cover.

**IMPORTANT: Discharge and Inlet Pump / Valve MUST BE wired for proper operation and programming.**

### Smart Toilet Control (03 Models)

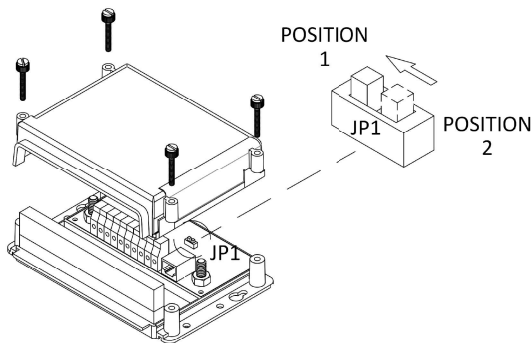
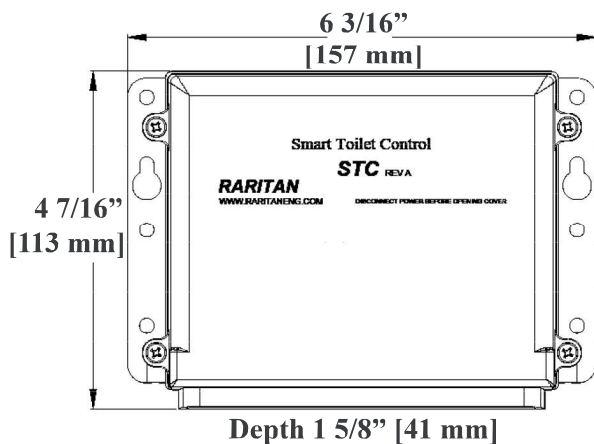

JP1 IS FACTORY PRESET TO POSITION 2 (WALL PANEL MODELS). TOILETS UTILIZING A FLUSH HANDLE MUST SLIDE JP1 TO POSITION 1.

## WIRING

### WARNING: Hazard of Shock and Fire

- Make sure power is off before proceeding.
  - Always use proper wire, wire connectors and fuse/circuit breaker. See Specification Chart.
  - Secure wire properly.
  - Do not connect appliances to toilet circuit.
1. Determine proper wire size by measuring distance from:
    - Power Source to toilet and back to power source.
    - Remote pump units - also include distance from power source for remote pump to remote pump and back. Same wire gauge must be used for both discharge and remote pump.
  2. Install fuse/circuit breaker in positive line at source.
  3. Wire using FIG 1, 2, 3, 4, 5, or 6.

FIG 1 WIRING FOR MOMENTARY FLUSH HANDLE CONTROL REMOTE PUMP 02 MODEL

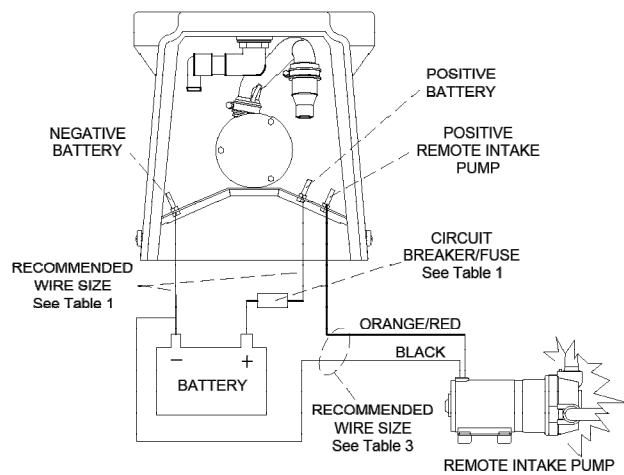

FIG 2 WIRING FOR MOMENTARY FLUSH HANDLE CONTROL FRESH WATER 02 MODEL

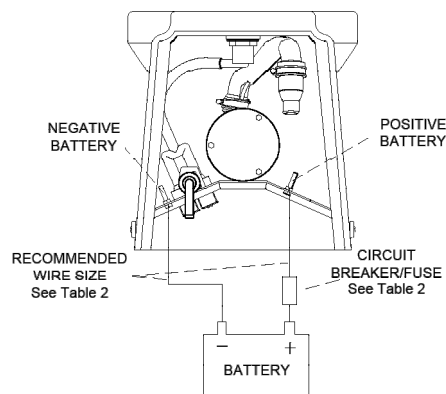

FIG 3

### WIRING FOR FLUSH HANDLE WITH SMART TOILET CONTROL FRESH WATER 03 MODEL

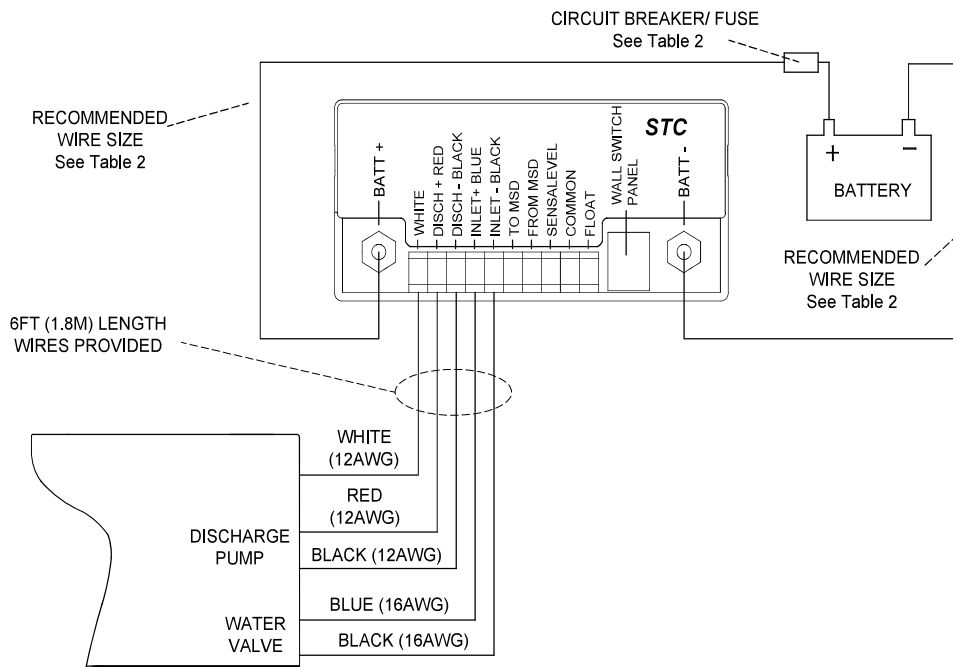
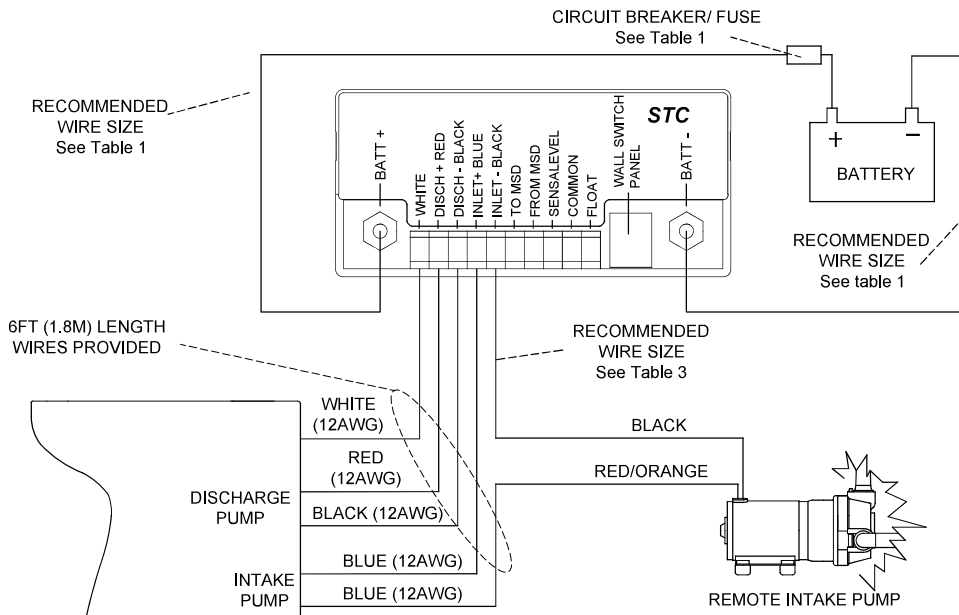
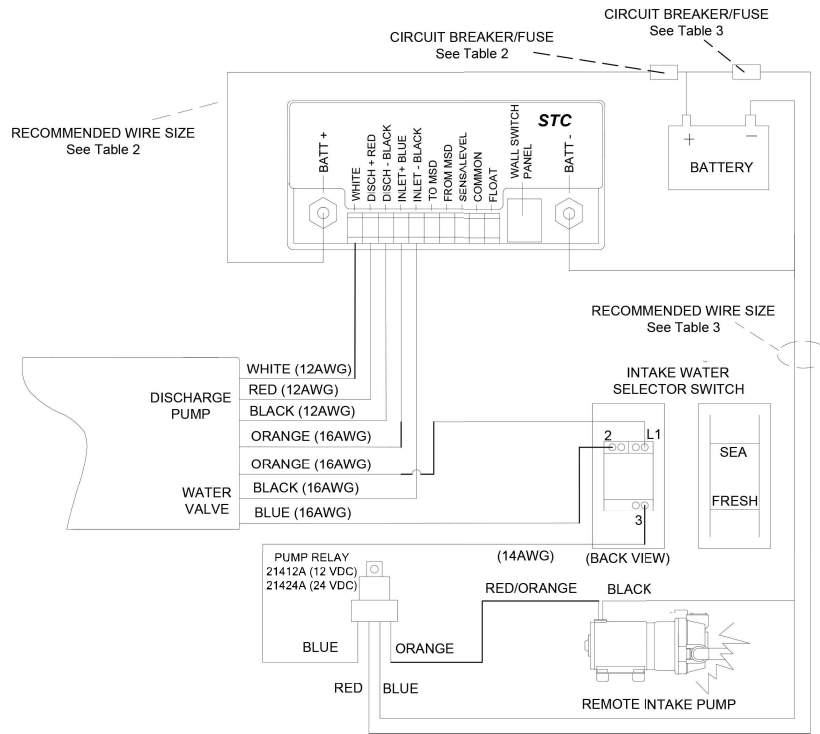

FIG 4

### WIRING FOR FLUSH HANDLE WITH SMART TOILET CONTROL REMOTE PUMP 03 MODEL



**FIG 5 WIRING FOR FLUSH HANDLE WITH SMART TOILET CONTROL SEA/FRESH 03 MODELS**



**FIG 6 WIRING FOR MOMENTARY FLUSH TOILET CONTROL SEA/FRESH 02 MODELS**

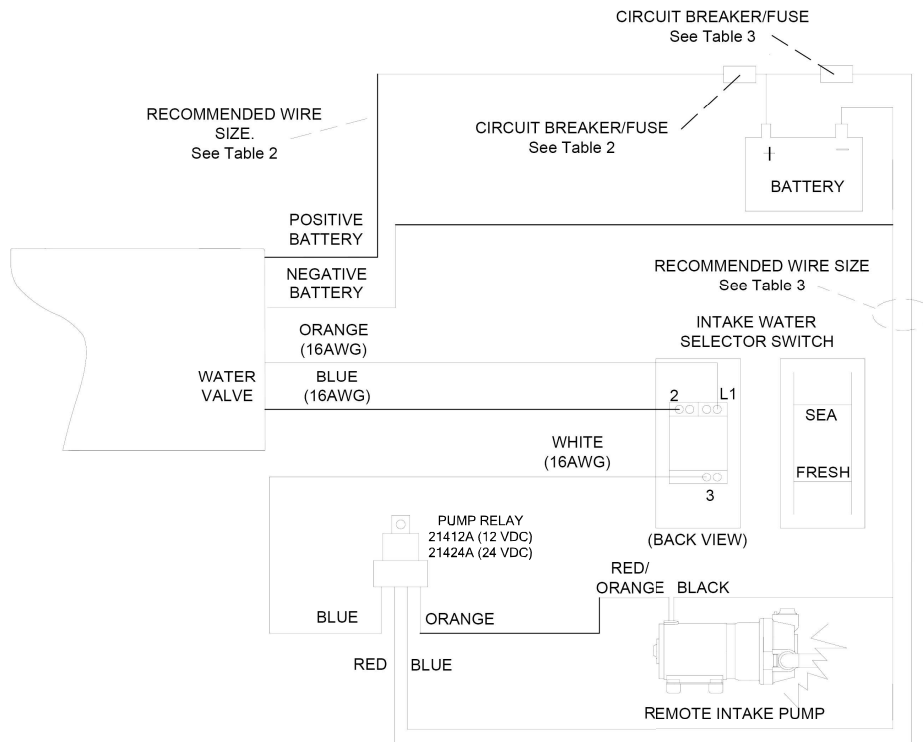

**MSD OPERATION**

Atlantes 03 Models only (Equipped with STCH Smart Toilet Control Handle).

- To start Electroscan (EST) or Purasan EX/Purasan EX2 (PSTEX/PSTEX2) from Toilet Flush Handle, wire per FIG 7.
- To start/flush toilet by activating the Electroscan or Purasan EX/Purasan EX2, wire per FIG 8.

For lectra/san MC, EC or Purasan call Raritan Customer Service.

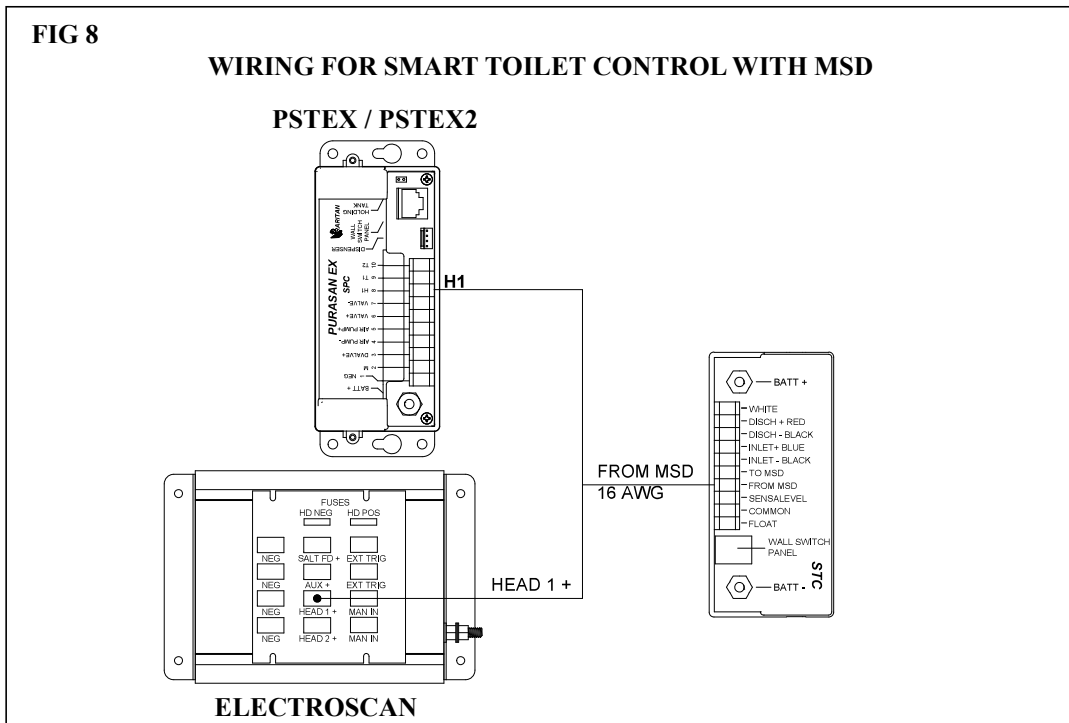
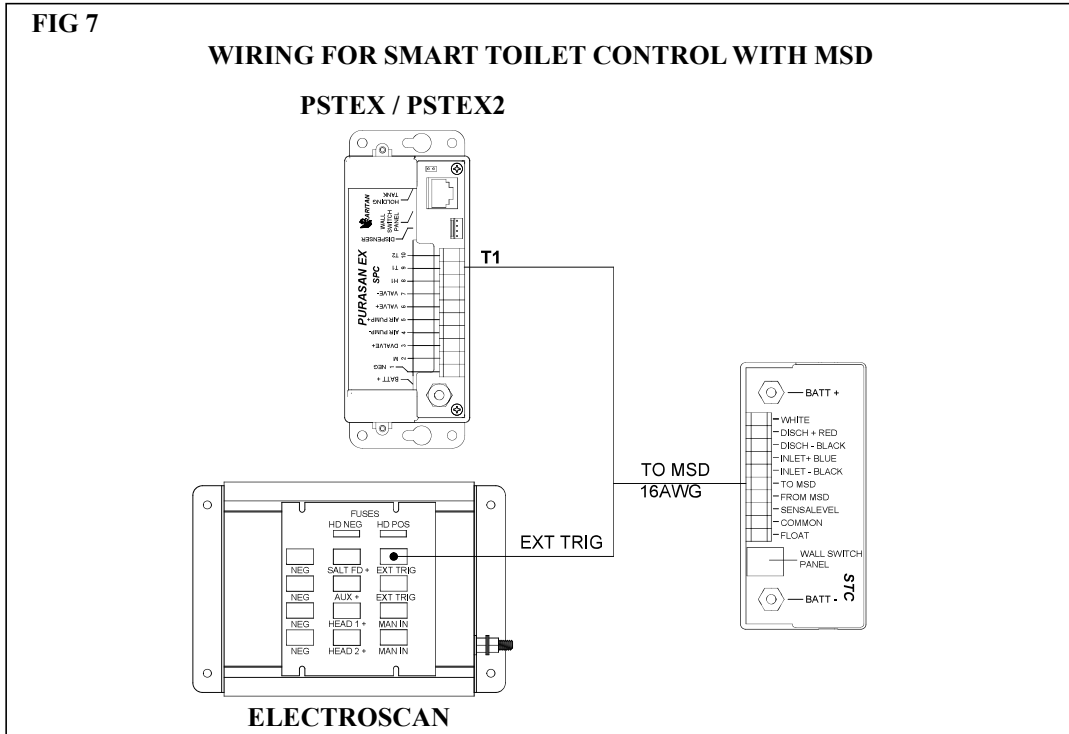

## Programming Smart Toilet Control

**NOTE:** For most installations, factory default settings will work. To make changes to timing to optimize the flushing, follow these instructions.

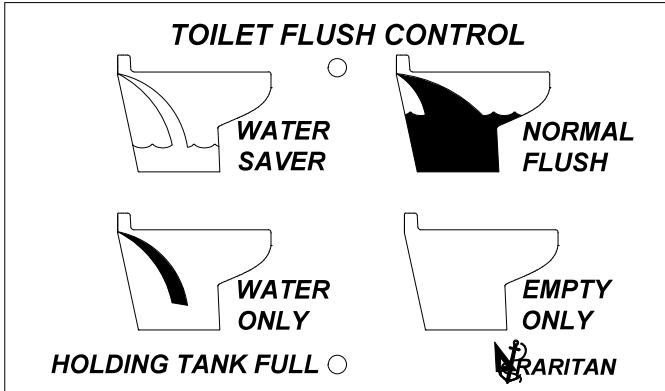

**The Raritan Smart Toilet Control has two different flush modes:**

### 1. Sequential Flush (Factory Default Setting):

In this mode, the toilet will add water and discharge waste separately. This fill/empty cycle will repeat three times during the NORMAL FLUSH cycle. At the end of this sequence cycle, a short pause will be followed by a final fill to leave water remaining in the bowl.

This mode is designed to provide the most efficient flush possible while using the least amount of water.

### 2. Continuous Flush:

In this mode, the toilet will add water to wet the bowl first and then the inlet and discharge run together for the remainder of the cycle. At the end of this continuous cycle, a short pause will be followed by a final fill to leave water in the bowl.

This mode may be more suitable for installations in which a continuous flow of water is desired and water use is not as great a concern.

## Changing flush mode from Sequential to Continuous and vice versa:

1. Hold the WATER ONLY and EMPTY ONLY buttons down together for three seconds. The Holding Tank Full LED will flash THREE times indicating you have entered program mode.
2. Push the WATER SAVER button once.
3. Push the EMPTY ONLY button. Flush mode will switch from Sequential to Continuous or vice versa. The Holding Tank Full LED will flash THREE times indication you have left program mode.

### Programming Smart Toilet Control:

The Raritan Smart Toilet Control is factory set to work in most installations and no programming is required. The following instructions can be used to modify timings if desired:

All flush cycles have an initial fill time (T1), Discharge/Empty time (T2) and water retention fill time (T3).

### Factory default settings for the NORMAL FLUSH are as follows:

Sequential mode: T1= 3 sec, T2= 3 sec, T3= 2 sec

Continuous mode: T1= 3 sec, T2= 12 sec, T3= 2 sec

### Step 1 - Entering program mode:

Hold the WATER ONLY and EMPTY ONLY buttons down together for 3 seconds. The Holding Tank Full LED will flash THREE times indicating you have entered program mode - release both buttons.

### Setting T1 initial fill time:

After entering program mode (Step 1 above) push the NORMAL FLUSH button once. Continue to press the NORMAL FLUSH button equivalent to the number seconds you wish water to enter the bowl: (1 push = 1 second, 2 pushes = 2 seconds, etc.). The Tank LED will flash after each valid key push. The maximum inlet time is 20 seconds. When finished, push the EMPTY ONLY button to store this value and exit. The Holding Tank Full LED will flash THREE times indicating you have left program mode.

**Setting T2 Discharge Pump Time:**

After entering program mode (Step 1, pg 7) push the EMPTY ONLY button once. Continue to press EMPTY ONLY button equivalent to the number of seconds you wish water to exit the bowl:  
(1 push = 1 second, 2 pushes = 2 seconds, etc.).

The Tank LED will flash after each valid key push. The maximum empty time is 20 seconds. When finished, push the NORMAL FLUSH button to store this value and exit. The Holding Tank Full LED will flash THREE times indicating you have left program mode.

**NOTE:** When in Continuous mode, the WATER SAVER empty time will operate at half of the NORMAL FLUSH time setting (Wall switch models only).

**Setting T3 Water Retention Fill Time:**

After placing the unit in program mode (step 1, pg 7) push the WATER ONLY button once. Continue to press the WATER ONLY button as follows to leave water standing in the bowl:  
(1 push = ZERO seconds, 3 pushes = 2 seconds, 4 pushes = 3 seconds, etc).

The Tank LED will flash once indicating a valid key push. The maximum water retention time is 10 seconds. When finished, push the NORMAL FLUSH button to store this value and exit. The Holding Tank Full LED will flash THREE times indicating you have left program mode.

**Extending pause for water retention:**

If water siphons out of the bowl after the flush sequence is complete, some installations may need a longer pause before retention fill. The factory set pause is for 2 seconds, but can be changed to 10 seconds. The following procedure will enable/disable extended pause time:

1. Enter program mode (Step 1, pg 7).
2. Push the WATER SAVER button. This will disable/enable the 10 second pause mode.
3. Push the WATER SAVER button again to exit program mode. The Holding Tank Full LED will flash THREE times indicating you have left program mode.

**TROUBLESHOOTING**

Observation or Issue	Action
Water does not empty all the way in the first cycle	Increase discharge time (T2)
Water empties, but discharge pump runs more than a second after all water is gone in first cycle	Decrease discharge time (T2)
Solids and toilet paper remain in the bowl after first cycle	Increase initial fill time (T1)
Water level in too high after initial fill cycle	Decrease water retention time (T3)
There is no water or little water left in the bowl	Increase water retention time (T3)
Water siphons out (of bowl) after 10 to 15 minutes	Enable longer pause before retention fill

**FOR LIMITED WARRANTY TERMS AND CONDITIONS PLEASE REFER TO TOILET MANUAL**

	<p>530 Orange Street, Millville, NJ 08332 USA          Telephone: 856-825-4900 FAX: 856-825-4409  <a href="http://www.raritaneng.com">www.raritaneng.com</a></p>
---	--