



PHII



Mid-priced, high quality, non-macerating manual. Reliable, high-quality design uses sea or lake water.

Benefits

- Good choice for sailboats and mid-size powerboats
- Simple design means economical, trouble-free quiet operation
- Powerful flushing action
- Simple and flexible installation for mounting above or below waterline
- Easy to clean and maintain
- Dry pumping is easier because air vent reduces back pressure
- Double action piston pump simultaneously draws new flush water as it discharges the wastewater
- Can be used with on-board treatment systems (such as the electroscan®) and/or holding tanks
- Each unit is assembled by hand, individually tested and backed by Raritan's one-year Limited Warranty and legendary technical support team

Options

- Choice of full-size household-style or marine-size white porcelain bowl
- Can be mounted for pumping on either left or right

Raritan products are chosen by powerboat, sailboat, houseboat and RV owners and manufacturers the world over for their dependability, environmental responsibility, simplicity of installation, operation and maintenance. The product line includes house-hold style toilets, marine toilets, marine sanitation devices and systems, cleaning products, icemakers, water heaters and rudder angle indicators.

To view our complete line as well as obtain installation and servicing guides: visit www.raritaneng.com

The PHII operates by using a double action piston pump that simultaneously draws new flush water as it discharges the wastewater. By using raw water for flushing, on board water supplies can be reserved for essential freshwater use.

The PHII pump has a unique, easily replaceable seal cartridge. A simple quarter turn of the inlet water valve control knob allows the bowl to be pumped dry without using additional water. This provides the user with the option of emptying the bowl while in heavy seas. A special air vent reduces back pressure.

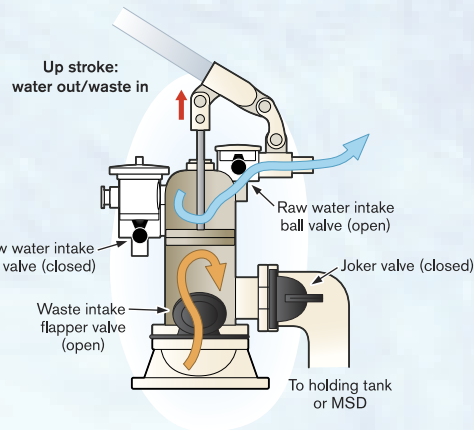
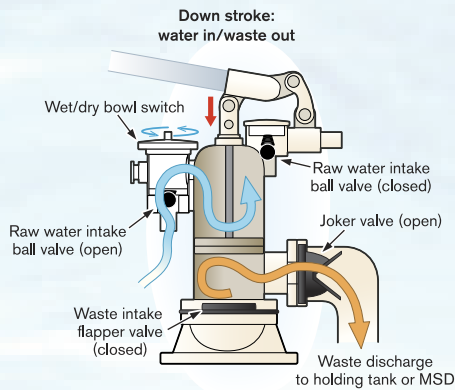
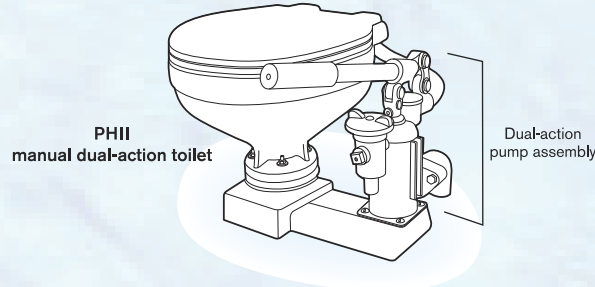

PHII Specs

BOWL TYPE	A	B	C	D	E
MARINE	17 3/8 (442)	17 (432)	10 (254)	14 1/4 (362)	18 (458)
HOUSEHOLD	NA (SEE B)	20 (508)	11 1/2 (292)	14 1/2 (368)	18 1/4 (464)

inch
(mm)

Shipping Weight: 30-41 lbs (14-19 kg)

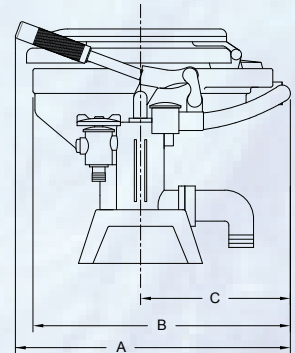
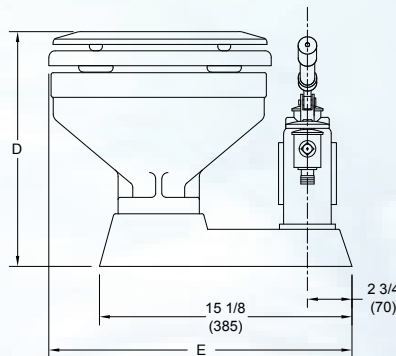

Conversion kit to electric

Part #	Description
P104E12	12 volts
P104E24	24 volts

Sample of Models

Part #	Description	
PHII	PHII, Manual Operation, White	marine-size bowl
PHHBII	PHII, Manual Operation, White	household-style bowl



For more information contact:
 Raritan Engineering Company Inc.
 530 Orange Street
 Millville, NJ 08332, USA
 Telephone: 856-825-4900
 Toll Free: 1-800-352-5630
 Fax: 856-825-4409
 e-mail: info@raritaneng.com